



C.T.M. MOBILITY SCOOTER

HS-898 Instruction Booklet



TABLE OF CONTENTS

INTRODUCTION	1
IMPORTANT PRECAUTIONS	2
ELECTROMAGNETIC INTERFERENCE AND WARNINGS	3
IDENTIFICATION OF PARTS	5
CHARGING THE BATTERIES	11
DISASSEMBLING YOUR SCOOTER	12
ASSEMBLING YOUR SCOOTER	13
CARE AND MAINTENANCE	14
OPERATING YOUR SCOOTER	15
TROUBLESHOOTING	17
TECHNICAL SPECIFICATIONS	19

INTRODUCTION

Thank you and congratulation on purchasing your new C.T.M. Mobility Scooter. It is designed to provide you with transportation ability indoors and outdoors.

We pride ourselves on providing safe and comfortable products. Our goal is to ensure your complete satisfaction. We sincerely hope you enjoy your C.T.M. Mobility Scooter.

Please read and observe all warning and instruction provided in owner's manual before you operate with various convenient function of this scooter. Also, please retain this booklet for future reference.

If you have any question, you can contact :

CHIEN TI ENTERPRISE CO., LTD.

No.13, Lane 227, Fu Ying Rd., Hsin Chuang, Taipei, Taiwan,

Tel : +886-2-2903-2987 Fax : +886-2-2903-8807

E-Mail : sales@chienti.com.tw http : //www.chienti.com.tw

Information of European Representative :

EMERGO EUROPE

Molenstraat 15

2513 BH, The Hague

The Netherlands

IMPORTANT PRECAUTIONS

Only one person at a time could ride a C.T.M. Mobility Scooter.

Maximum load is 181 kgs / 399 pounds.

Turn key off before getting on or off.

Always drive carefully and be aware of others using the same area.

Always use pedestrian crossings wherever possible. Take extreme care when crossing roads.

Do not drive on slope exceeding 10 degree, and take extreme care when turning on slope.

Do not use full power when turning to sharp corner.

Take great care and drive in low speed when backing up, riding downhill or on uneven surface, and climbing curb.

Scooter may not operate well in high humidity.

If you are caught in rain, it is handy to carry a scooter canopy. It offers complete protection for your and scooter.

Never put scooter in neutral when staying on slopes.

Follow traffic laws when riding outside.

ELECTROMAGNETIC INTERFERENCE AND WARNINGS

CAUTION: It is very important that you read this information regarding the possible effects of Electromagnetic Interference on your motorized scooter.

Powered wheelchairs and motorized scooters may be susceptible to electromagnetic interference (EMI), which is interfering electromagnetic energy (EM) emitted from sources such as radio stations, TV stations, amateur radio (HAM) transmitters, two-way radios, and cellular phones. The interference (from radio wave sources) can cause the motorized scooter to release its brakes, move by itself, or move in unintended directions. It can also permanently damage the motorized scooter control system. The intensity of the interfering EM energy can be measured in volts per meter (V/m). Each motorized scooter can resist EMI up to a certain intensity. This is called its "immunity level." The higher the immunity level, the greater the protection. At this time, current technology is capable of achieving at least a 20 V/m immunity level, which would provide useful protection from the more common sources of radiated EMI. The immunity level of this motorized scooter model is not known.

There are a number of sources of relatively intense electromagnetic fields in the everyday environment. Some of these sources are obvious and easy to avoid. Others are not apparent and exposure is unavoidable. However, we believe that by following the warnings listed below, your risk to EMI will be minimized.

The sources of radiated EMI can be broadly classified into three types :

1. Hand-held portable transceivers (transmitters-receivers) with the antenna mounted directly on the transmitting unit. Examples include: citizens band (CB) radios, "walkie talkie," security, fire, and police transceivers, cellular telephones, and other personal communication devices



Some cellular telephones and similar devices transmit signals while they are ON, even when not being used

2. Medium-range mobile transceivers, such as those used in police cars, fire trucks, ambulances, and taxis. These usually have the antenna mounted on the outside of the vehicle; and
3. Long-range transmitters and transceivers such as commercial broadcast transmitters (radio and TV broadcast antenna towers) and amateur (HAM) radios



Other types of hand-held devices, such as cordless phones, laptop computers, AM/FM radios, TV sets, CD players, and cassette players, and small appliances, such as electric shavers and hair dryers, so far as we know, are not likely to cause EMI problems to your motorized scooter.

Motorized Scooter Electromagnetic Interference :

Because EM energy rapidly becomes more intense as one moves closer to the transmitting antenna (source), the EM fields from hand-held radio wave sources (transceivers) are of special concern. It is possible to unintentionally bring high levels of EM energy very close to the motorized scooter control system while using these devices. This can affect motorized scooter movement and braking. Therefore, the warnings listed below are recommended to prevent possible interference with the control system of the motorized scooter.

Warnings :

Electromagnetic interference (EMI) from sources such as radio and TV stations, amateur radio (HAM) transmitters, two-way radios, and cellular phones can affect motorized scooters. Following the warnings listed below should reduce the chance of unintended brake release or motorized scooter movement which could result in serious injury.

1. Do not operate hand-held transceivers (transmitters-receivers), such as citizens band (CB) radios, or turn ON personal communication devices, such as cellular phones, while the motorized scooter is turned ON;
2. Be aware of nearby transmitters, such as radio or TV stations, and try to avoid coming close to them;
3. If unintended movement or brake release occurs, turn the motorized scooter OFF as soon as it is safe;
4. Be aware that adding accessories or components, or modifying the motorized scooter, may make it more susceptible to EMI; and



There is no easy way to evaluate their effect on the overall immunity of the motorized scooter.

5. Report all incidents of unintended movement or brake release to the distributor listed on the inside front cover of this manual. Note whether there is a source of EMI nearby.

Important Information :

1. 20 volts per meter (V/m) is a generally achievable and useful immunity level against EMI (as of May 1994). The higher the level, the greater the protection.
2. The immunity level of this product is at least 20/Vm.

IDENTIFICATION OF PARTS

Before attempting to drive this scooter on your own, it is important that you familiarize yourself with the controls, and how to operate



Figure 1 - HS-898 Front View



Figure 2 - HS-898 Control Panel

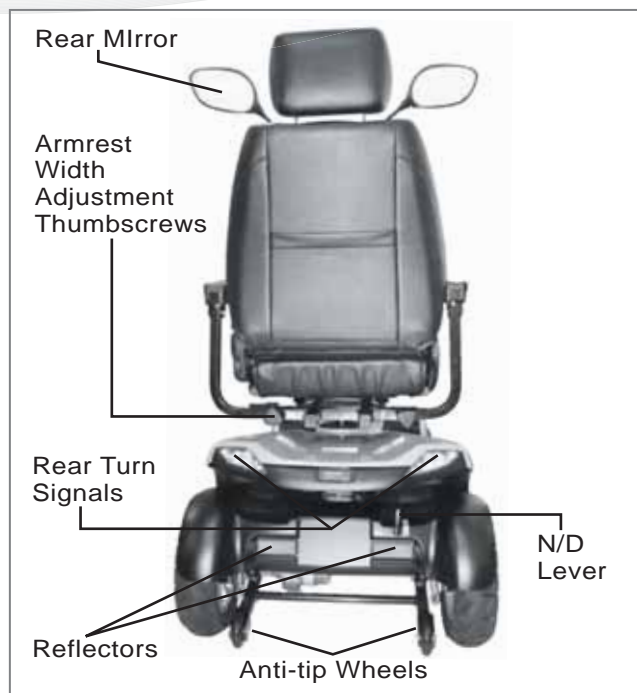

Figure 3 - HS-898 Rear View

FUNCTION OF PARTS :

MAIN SWITCH (A)

1. By turning the key clockwise to NO to turn on the power
2. By turning the key anticlockwise to OFF to turn off the power.

Speed Dial Knob (B)

The Rabbit means fast and Turtle is slow.

By turning this you control total speed transferred to thumb controls.

 **Do not set the speed at maximum when operating the scooter. Adjust the speed at maximum when inclining a slope, and adjust to minimum speed when declining a slope.**

Horn Button (C)

Pressing down the button to sound buzzer.

Battery Gauge (D)

There is a meter shows batteries capacity status.

When battery gauge's light trends to , it means sufficient power capacity.

When battery gauge's light trends to , it means insufficient power capacity.

 **Check battery's capacity before driving, and charging batteries when at low power.**

TOP CONTROL PANEL (Hi/Lo)

High & Low Speed Switch allows speed to be changed from the normal maximum 12.8 kmph to half for pavement use.

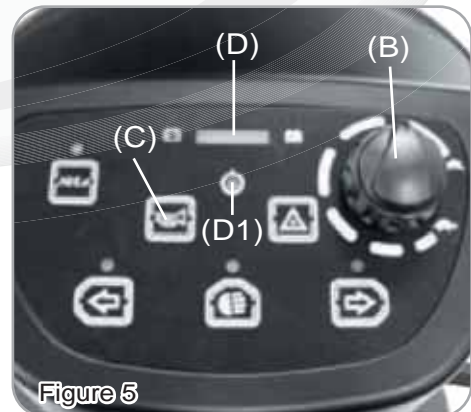
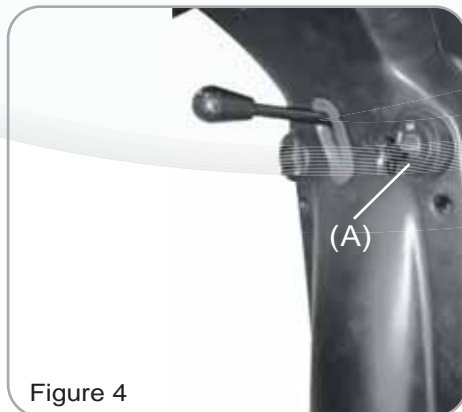

Panel Control

- Pressing down  to activate left turn signal.
- Pressing down  to activate right turn signal.
- Pressing down  to activate warning light.
- Pressing down  to activate headlight.
- Pressing down  to activate Hi/Lo speed.

Indicator:

1. Light means activated Hi/Lo speed.
2. Light means activated left turn signal
3. Light means activated headlight.
4. Light means activated right turn signal



Battery Gauge

Capacity Display	LED	D1	D2	D3	D4	D5	D6	D7	Battery Capacity%
	7								>80
	6								<80
	5								<65
	4								<50
	3								<35
	2								<25
	1								<20
	D1、 D2 : Red LED D3、 D4 : Amber LED D5、 D6、 D7 : Green LED								
Operation Characteristic	LED blocks will only decrease gradually during driving.								
Usage Condition	(1)When turn off power (2)When charging, function will shut off.								

Low Voltage Warning Sound

Operation Characteristic	Warning sound will signal, when battery capacity's lower than 25%, after turn on the power, 2 short "Be" sounds will signal 3 times (Be Be-Be Be-Be Be)
Remark	Can be set as on or off.

Warning Sound (On, Off) Setting

Operation Characteristic	Sound of turn signal, stop, low voltage, reversing can be set as on or off
Description of Volume Setting Steps	<ol style="list-style-type: none"> 1.Ensure power is turned off 2.Pressing left and right turn signal buttons downwards simultaneously. 3.Turn on the power. 4.After 2 seconds, LED (D7) flashes to indicate the setting start, if hold on buttons for 10 seconds without releasing (left and right turn signal buttons) will automatically leave setting mode. 5.Pressing volume setting button (As Stop (Warning) light button) to access volume setting mode, by pressing button (Ex: Stop (Warning) light button) to adjust volume. 6.Waiting for 10 seconds without action, or pressing left and right turn signal buttons downwards simultaneously for 2 seconds to return to normal operation mode.

Table of Warning Sound Settings

Function	Volume Button	Volume Adjustment
Reverse Warning Sound	Head Light Button	<div style="text-align: center;">Flash</div> <p>Off Minimum Low Mid Loud</p> <p>Except horn volume can not be set as off</p>
Turn Signal Warning Sound	Left or Right Turn Signal Button	
Stop (Warning) Warning Sound	Stop (Warning) Light Button	
Low Voltage Warning Sound	Hi & Lo Button	
Horn Volume	Horn Button	

P.S: Pressing volume button (ex:Stop (Warning) to access volume adjustment mode, the LED displays to volume blocks and the volume (ex:Stop (Warning) Sound signal, press (Stop (Warning) Light button again, the volume and LED will decrease gradually, by pressing button once will increase or decrease one block:

Loud >> Mid >> Low >> Minimum >> Off

Examples	<p>Reversing Warning Sound Volume Adjustment</p> <ol style="list-style-type: none"> 1.Turn off the power (Key off) 2.Pressing left and right turn signal buttons downwards simultaneously. 3.Turn on the power(Key on) After 2 seconds, LED (D7) flashes (meaning accessed in volume setting mode), Release the buttons within 10 seconds (left and right turn signal buttons). 4.Pressing Head Light button to access Reverse Warning Sound. 5.Pressing Head Light button to adjust volume 6.After setting, waiting for 10 seconds without action, or pressing left and right turn signal buttons downwards simultaneously for 2 seconds to return to normal operation mode.
Default	<p>Turn Signal Warning Sound=Mid Stop (Warning) Light Warning Sound=Mid Low Voltage Warning Sound=Mid Reversing Warning Sound=Mid Horn Volume=Loud</p>

Thumb Lever

Pulling right thumb lever (E) moves scooter forward. Pulling left thumb lever (F) moves the scooter backward. (This can be reversed if required by local dealer.) Releasing both, engages automatic brake. These are also your accelerator. The further you depress them, the faster you go. (Subject to the position of the Rabbit/Turtle control).

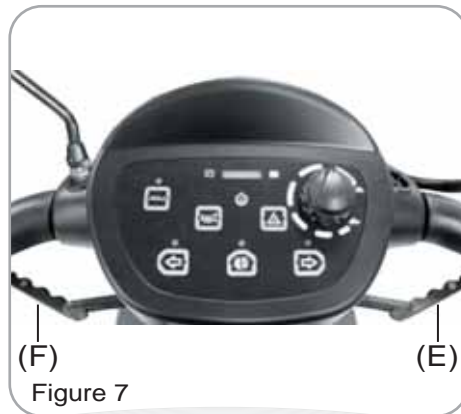
**Tiller Angle Adjustment**

Pulling the tiller adjustment (G) downwards to adjust tiller's angle and release to lock at a desired comfortable position.

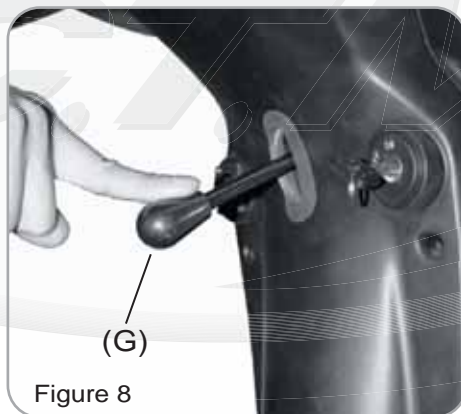
**Seat Swivel Adjustment**

Setting at a comfortable angle by pulling lever (H) upwards to rotate seat (a) left and right..

Seat fore-aft Adjustment

Setting at a comfortable position by lifting lever (I) upwards to adjust the seat (a).

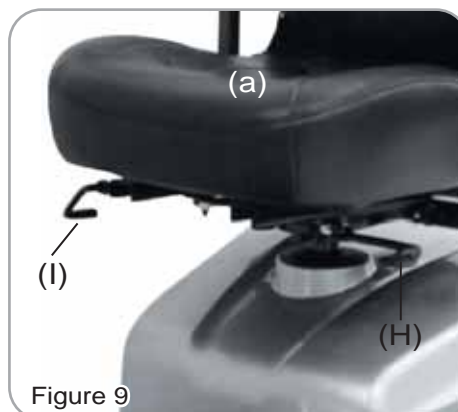

Armrest width Adjustment Thumbscrews

1. Loosen the two thumbscrews (K) to adjust arm width tighten again to lock in at desired position.
2. Adjust the attached screw (J)'s height, to control armrest's angle.

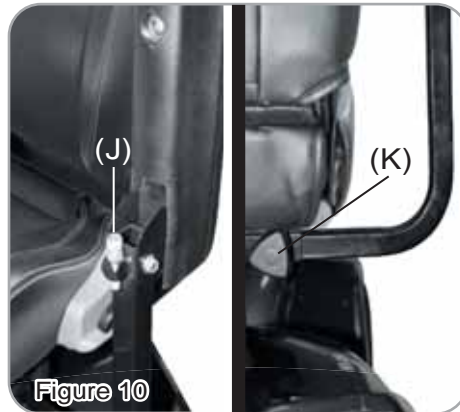
**Anti-tip wheels (M)**

Helps keep scooter from tipping over.

Free-Wheeling Lever (L)

When lever is in N (Neutral) position, scooter can be moved manually without power. When lever is in D (Drive) position, scooter can be driven. Normal position is D.

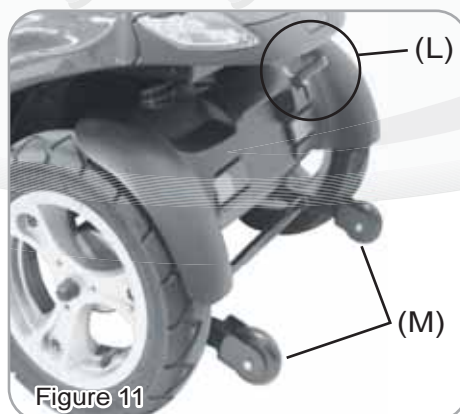

CHARGING THE BATTERIES

Batteries must be charged before using the scooter for the first time and should be recharged after each day use. You will need the scooter and the battery charger.



Each country may supply different charger. The charging procedure may be different from below.

If you require more details, please contact your authorized dealer.



Be sure the scooter key is in the OFF position



Figure 12

1. Insert battery charger cord into the charger connector on the charger output. Refer to above figure for correct position
2. Plug the other end of the battery charger cable into a standard electrical outlet.
3. Turn the power on. Normally, The LED (Power) Light will turn on when electric current passes.
4. Charging starts. During charging, LED (Charge) will indicate orange light, when it turns to green light, that means well-charged.
5. LED indication
 - LED(POWER) - GREEN LIGHT ON : Power On.
 - LED(CHARGE) - ORANGE LIGHT ON : Charging / GREEN LIGHT ON : Fully Charged
6. Charger Trouble Shooting
 - (A) If LED (POWER) light is off
 - Check the input voltage (115V/230V) is the same as you adjust.
 - If light is still off, please check and repair the battery charger.
 - (B) If LED (CHARGE) light is off
 - Check to see clips connection is correct.
 - If the battery is fully charged, the LED (CHARGE) light will be off.
 - If light is still off, the battery may be defective.
 - (C) If ORANGE light can turn to GREEN
 - The battery can not be charged. Please check and recover it.
 - (D) If ORANGE light turns to GREEN immediately
 - Check to see the battery is fully charged, if not, The battery may be defective
 - Check and recover it.



The time needed to recharge will vary depending on the depletion of the batteries. Charging for longer than necessary will not harm the batteries. They can not be overcharged.

Keep in mind these rules :

Fully charge batteries at least once a month, or more if you use scooter regularly.
 Charge after each trip exceeding 3 kilometers.
 If storing your scooter for some time (1 month or more), make sure that batteries are fully charged, and on returning, charge them again before using scooter.
 Batteries will only give maximum performance after scooter has been used, and batteries have been recharged up to 10 times. A bit like breaking in a new car.

DISASSEMBLING YOUR SCOOTER

Disassembling Basket

By lifting the basket (O) upwards.

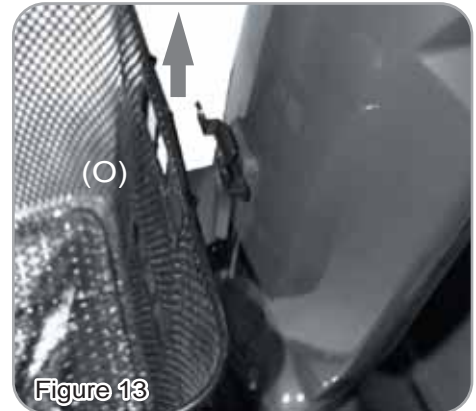

Disassembling Seat

By lifting lever (H) and seat (a) upward.

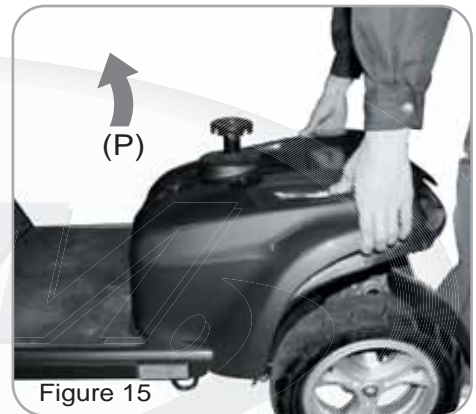
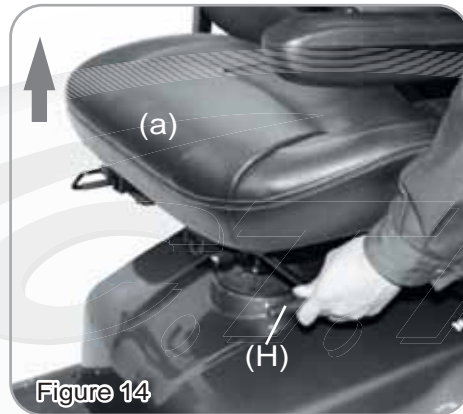

Rear Compartment Cover

Open the Compartment Cover (P) according to arrow's direction.

Disassembling Batteries

Tear off battery straps (Q) and disconnect battery terminals (R) to remove the batteries (b).



**Be careful when removing batteries, as batteries are heavy.
Do not contact battery terminal \ominus \oplus with any metals to avoid danger.**

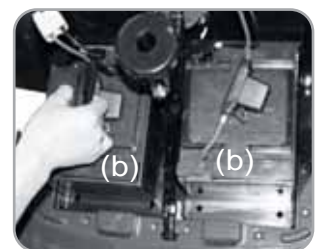
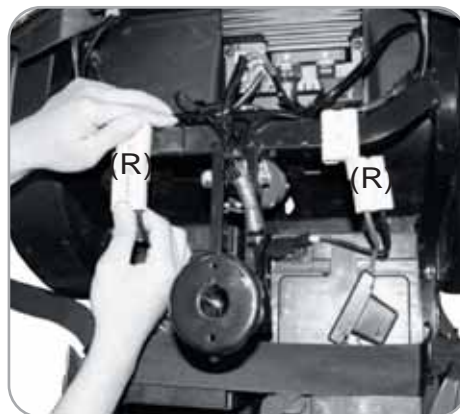
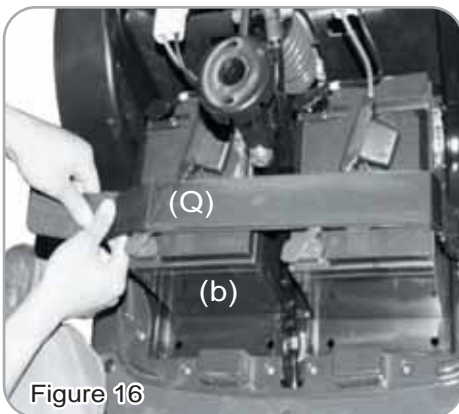

ASSEMBLING YOUR SCOOTER

To assemble scooter, you can repeat disassembly directions in reverse. Abbreviated directions are given below. Refer to Figures on pages 12 to locate parts.

1. Use the tiller adjustment to move tiller up and out of the way.
2. Place front basket.
3. Place battery pack in battery compartment.
4. Place seat on seat post and tighten seat locker knob.



CARE AND MAINTENANCE

Cleaning Your Scooter :

If your scooter is dirty, use a damp or lightly soapy cloth to wipe it down. Do not use running water to wash or rinse scooter in order to protect electrical parts. Polish with an automotive liquid polish.

Maintaining Your Scooter :

All maintenance and repair of scooter should be done by an authorized dealer. The following areas required periodic inspection:

Tire pressure between 30-35 lbs

All electrical connections are firmly attached

Storing Your Scooter :

Between uses, your scooter is best stored in a dry location.

Remark :

Obstacle height approx. 7cm (Figure.17)

Feasible groove width approx. 20cm, scooter must go straight line to across the groove. (Figure.18)

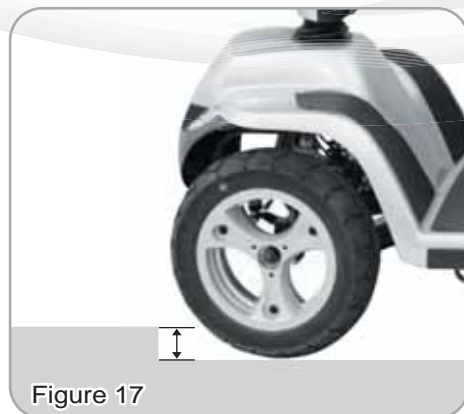

OPERATING YOUR SCOOTER

You could make the following adjustments to increase your comfort when driving.

adjust seat position.

adjust armrest width to comfortable position.

adjust tiller's angle.

1. Before operating your scooter, check the following:

free-wheeling lever in D

speed dial knob is at turtle picture.

2. Sit on scooter and turn on key, Battery Gauge meter should be indicate at F.

The Self-Diagnostic Warning Light should not be blinking.

3. When your hands rest comfortably on handlebars, the thumb levers should be within easy reach. The right lever moves scooter forward, the left one moves it backward. When you release both levers, scooter will stop.



This scooter has automatic braking system. Release the thumb lever and brake will stop scooter.

4. Steer scooter by turning tiller toward the way you want to go.

5. Practice driving where there are is No obstacle. Start at the slowest speed and drive forward and backward; make some turns. As you get more comfortable, you can increase speed by turning speed dial toward picture of rabbit.

6. If Battery Gauge indicates , you should plan to recharge batteries very soon.

7. If scooter stops, locate the circuit breaker on top of battery pack. Push it and try driving again.

8. When you are finished riding, turn off the key before getting off.

9. If you are finished riding for the day, immediately recharge batteries.

See CHARGING THE BATTERIES, page 11.

Keep in mind these rules :

Release thumb levers and allow scooter to stop completely before changing from forward to reverse, or reverse to forward.

When turning to corner, swing front wheels widely, so back wheels will turn more tightly.

Use scooter only where it is safe for walking.

Drive in low speeds when reversing, riding downhill, over rainp or curb, or on uneven sukpace, downhills, ramps, curbs, or uneven surfaces.

Other Operating Information :

Hill climbing: You may need to use a higher speed. Turn to lower speed before going downhill.

Down slopes: proceed with downward slopes slowly, and set speed control in proximity of turtle. The closer speed control is set toward turtle, the slower scooter travels. However, this scooter will not self accelerate down hills due to the automatic braking, taking effect should you attempt to drive too fast.

Kerb climbing: Approach slowly from right angles to curb. A slight angle is permissible with a 4-wheel scooter. Do not attempt greater than a 7cm curb.

If Self-Diagnostic Warning Light starts to blink, identify problem from chart on page 17 and take action.

If the scooter breaks down and must be moved, get off scooter, engage Free-Wheeling Lever to N, push scooter slowly to a safe location, and push lever back to D.



In unlikely event of a panel display error, you need to re-set the display system by cycling the on/off main switch. The display circuitry is independent of the motor control system. A display console error does not affect scooter speed control.

TROUBLESHOOTING

Here are some suggestions about solving problems you may have with your scooter. There is a Self-Diagnostic Warning Light on the Control Panel. To check the Self-Diagnostic Warning Light, turn on the key and count the number of blinks on the Warning Light.

Flash	Description	Meaning
1	Battery Low	The batteries are running low. Recharge the batteries.
2	Low Battery Fault	The batteries have run out of charge. Recharge the batteries. Check the battery and associated connections and wiring.
<p>The Low Battery Fault Flash code, described above, is a requirement of various safety standards.</p> <p> The scooter will output a visible and audible low battery warning if the battery voltage drops below 90% of its cut-off voltage. The warning will be two short flashes, and will take priority over all other flash codes in the system.</p>		
3	High Battery Fault	Battery voltage is too high. This may occur if overcharged &/or travelling down a long slope. If travelling down a slope, reduce your speed to minimize the amount of regenerative charging.
4	Current Limit Time-out or Controller too hot	The motor has been exceeding its maximum current rating for too long. The scooter may have stalled. Turn the controller off, leave for a few minutes and turn back on again. The motor may be faulty. Check the motor and associated connections and wiring.
5	Park Brake Fault	Either a park brake release switch is active or the park brake is faulty. Check the park brake and associated connections and wiring. Ensure any associated switches are in their correct positions.
6	Drive Inhibit	Either a Stop function is active or a Charger Inhibit or OONAPU condition has occurred. Release the Stop condition (seat raised etc.) Disconnect the Battery Charger Ensure the throttle is in neutral when turning the controller on. The Throttle may require re-calibration.
7	Speed Pot Fault	The throttle, speed limit pot, SRW or their associated wiring may be faulty. Check the throttle and speed pot and associated connections and wiring.
8	Motor Voltage Fault	The motor or its associated wiring is faulty. Check the motor and associated connections and wiring.

9	Other error	The controller may have an internal fault. Check all connections and wiring.
---	-------------	---

Other Problems

Low tire pressure: pump up tires to 30-50 lbs.

During charging, light on charger does not change to green: Contact your authorized dealer.

Scooter will not move when key is turned on:

1. Check Power Reserve Indicator on control panel, it should be lighting in green, yellow, and red zones.
2. Check Self-Diagnostic Warning Light, it should be steady. If it is flashing, see chart above for problem identification.
3. Check all electrical connections to be sure they are tight.
4. If none of above correct problem, contact your authorized dealer.

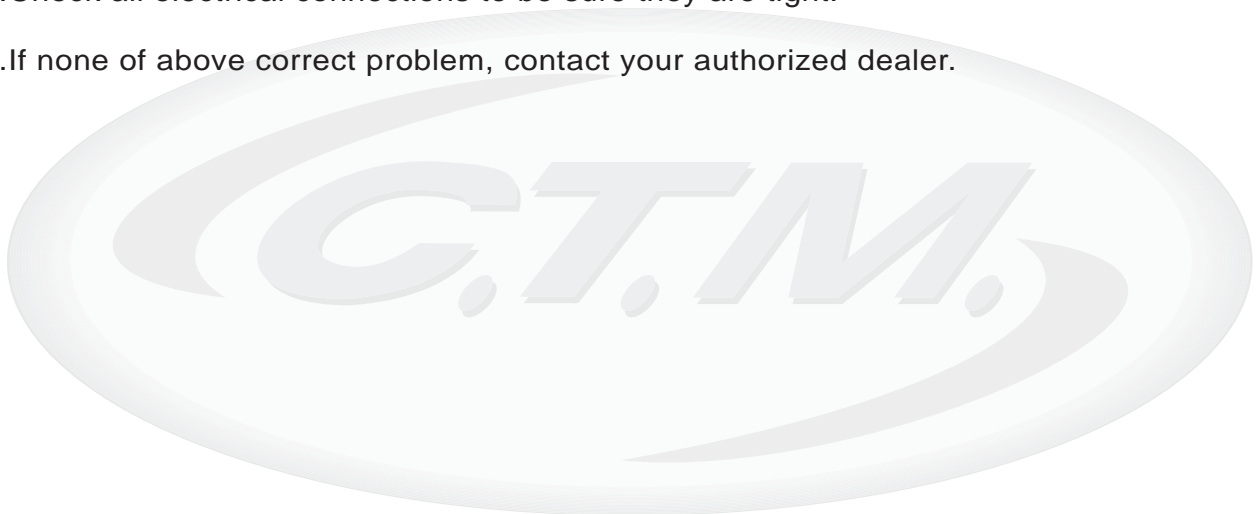

TECHNICAL SPECIFICATIONS

Overall Length	1440 mm / 57"
Overall Width	680 mm / 27"
Overall Height	1360 mm / 53.5"
Wheels:Front	330 mm / 13"
Wheels:Rear	330 mm / 13"
Weight w/ Batteries	117 kg / 258 lbs
Max. Speed	15 kmph / 9.3 mph
Weight Capacity	181 kg / 399 lbs
Ground Clearance	100 mm / 3.9"
Grade Climbable	10 degree
Curb Climbing	70 mm / 2.8"
Turning Radius	1600 mm / 63"
Suspension	Front & Rear
Brake	Electro-Mechanical
Seat Type	Sliding and Swivel Reclining Captain W/Headrest
Seat Width	520 mm / 20.5"
Motor Size	700W, 5000 r.p.m.
Battery Size	(2) 12V. 50Ah
Battery Weight	31 kg / 68 lbs
Travel Range	27 km / 16.8 Miles
Battery Charger	5A Off Board
Electronics	On / Off Key Switch, Battery Level Indicator, Speed Control Knob

*Subject to change without notice. (Issue A)