

LIBERTY *FT*

TECHNICAL MANUAL



This technical manual is designed to aid in the different procedures that may be needed for the Liberty FT wheelchair. This technical manual does not replace, but aids the owner manual, adjustment guides and instructions. The procedures shown in this technical manual should only be performed by an Assistive Technology Practitioner (ATP) or clinical professional trained to do wheelchair repairs, adjustments and retrofits.

Additional information can be found in the Liberty FT Owner Manual and Liberty FT Assembly Guide. The owner manual and adjustment guides can be found on the Ki Mobility website.

If you have any questions or concerns about any aspect of this wheelchair, this manual, or the service provided by us or your retail supplier, please do not hesitate to contact us by telephone at:

715-254-0991

In writing at:

Ki Mobility
5201 Woodward Drive
Stevens Point, WI 54481
U.S.A

Via email at:

sales@kimobility.com

Or via our Authorized EU Representative:

James Leckey Design
19C Ballinderry Road
Lisburn
BT28 2SA
Phone: 0800 318265 (UK) or 1800 626020 (ROI)
www.leckey.com



Table of Contents

Tools	3
Seat Height - Rear Wheels.....	4
Seat Height - Casters	6
Seat Height - Caster Positioning within Caster Fork	9
Seat Height - Axle Position	10
Seat Depth - Backrest	11
Seat Depth - Axle Plate.....	12
Backrest - Back Height.....	12
Seat Width	13
Non-Folding Frame	14
Axle Plate Construction	15
Caster Construction.....	16
Fork and Stem Replacement	17
Wheel Pull Correction	21
Adjusting Gas Springs	23
Replacing Gas Springs	24
Replacing Frame Cover	25
Fold Lever Replacement.....	26
Adjusting Depth	28
Changing Seat Sling	29
Changing Seat Rail	29
Changing to a Short Back.....	30
Replacing Tilt Cables	32
Installing Transit.....	34
Wheel Lock Configurations.....	35
Handrim Configurations.....	36
Handrim Construction.....	37
Footplate and Heel Loops	38
Pro ELR Adjustment.....	38
Rotating 4-Way Latch	39
Backrest Angle Adjustment	40
Seat Upholstery	41
Adjusting Height Adjustable T-Arm Position	42
Angle Adjustable Locking Flip Up Extendable Armrest	43
Anti-Tips.....	44
Multi-Angle Footrest	45

Tools

Please see the list below to identify the tools needed throughout this tech manual. Always check tools to ensure the ends are not stripped and that the tool can perform it's function properly without damaging any parts or hardware on the chair.

Tools Needed	
<ul style="list-style-type: none">• 2.5mm Allen Wrench	<ul style="list-style-type: none">• Two 8mm Wrenches
<ul style="list-style-type: none">• 3mm Allen Wrench	<ul style="list-style-type: none">• Two 10mm Wrenches
<ul style="list-style-type: none">• 4mm Allen Wrench	<ul style="list-style-type: none">• 13mm Wrench
<ul style="list-style-type: none">• 5mm Allen Wrench	<ul style="list-style-type: none">• 17mm Wrench
<ul style="list-style-type: none">• 5.5mm Allen Wrench	<ul style="list-style-type: none">• 19mm Wrench
<ul style="list-style-type: none">• 6mm Allen Wrench	<ul style="list-style-type: none">• 24mm Wrench
<ul style="list-style-type: none">• Utility blade	<ul style="list-style-type: none">• Phillips Screwdriver

Seat Height - Rear Wheels

Determine your wheel and caster selection based upon your desired seat height. Once determined, be sure to check Caster and Footrest Compatibility charts before ordering or making any physical changes to the chair. Also, be aware that a specific rear seat height may be accomplished with more than one type of axle plate. See axle plate positioning matrix to determine if your current axle plate may be utilized for your desired rear seat height.

Rear Wheel Size	Caster Size					
	4"	5"	6"	6" X 2"	8"	8" X 2"
	Seat Height					
12"	13	14	15	15	17	17
	13.5	14.5	15.5	15.5	17.5	17.5
	14	15	16	16	18	18
	14.5	15.5	16.5	16.5	18.5	18.5
	15	16	17	17	19	19
	15.5	16.5	17.5	17.5	19.5	19.5
	16	17	18	18	20	20
		17.5	18.5	18.5		
		18	19	19		
		18.5				
16"	14.5	14.5	15	15	17	17
	15	15	15.5	15.5	17.5	17.5
	15.5	15.5	16	16	18	18
	16	16	16.5	16.5	18.5	18.5
		16.5	17	17	19	19
		17	17.5	17.5	19.5	19.5
		17.5	18	18	20	20
		18	18.5	18.5		
	18.5	19	19			
16" with Low Poly Tire	13.5	14	15	15	17	17
	14	14.5	15.5	15.5	17.5	17.5
	14.5	15	16	16	18	18
	15	15.5	16.5	16.5	18.5	18.5
	15.5	16	17	17	19	19
	16	16.5	17.5	17.5	19.5	19.5
		17	18	18	20	20
		17.5	18.5	18.5		
		18	19	19		
	18.5					

Seat Height - Rear Wheels

Rear Wheel Size	Caster Size					
	4"	5"	6"	6" X 2"	8"	8" X 2"
	Seat Height					
20"	13	14	15	15	17	17
	13.5	14.5	15.5	15.5	17.5	17.5
	14	15	16	16	18	18
	14.5	15.5	16.5	16.5	18.5	18.5
	15	16	17	17	19	19
	15.5	16.5	17.5	17.5	19.5	19.5
	16	17	18	18	20	20
		17.5	18.5	18.5		
	18	19	19			
	18.5					
22"	14	14	15	15	17	17
	14.5	14.5	15.5	15.5	17.5	17.5
	15	15	16	16	18	18
	15.5	15.5	16.5	16.5	18.5	18.5
	16	16	17	17	19	19
		16.5	17.5	17.5	19.5	19.5
		17	18	18	20	20
		17.5	18.5	18.5		
	18	19	19			
	18.5					
24"	15	15	15	15	17	17
	15.5	15.5	15.5	15.5	17.5	17.5
	16	16	16	16	18	18
		16.5	16.5	16.5	18.5	18.5
		17	17	17	19	19
		17.5	17.5	17.5	19.5	19.5
		18	18	18	20	20
		18.5	18.5	18.5		
		19	19			
24" with Low Poly Tire	14.5	14.5	15	15	17	17
	15	15	15.5	15.5	17.5	17.5
	15.5	15.5	16	16	18	18
	16	16	16.5	16.5	18.5	18.5
		16.5	17	17	19	19
		17	17.5	17.5	19.5	19.5
		17.5	18	18	20	20
		18	18.5	18.5		
	18.5	19	19			

Seat Height - Casters

Seat Height - Caster Compatibility charts are utilized to prevent interference between the caster and side frame or caster and hanger/footrest. Higher degree hangers and larger casters are more likely to create interference. Use the charts below to determine if your wheel, caster, caster stem and seat height configuration will work with your desired hanger angle selection.

Caster Footrest Compatibility Matrix															
60° and 70° Extension Mount Hangers															
Caster Housing			Forward Caster Housing					Reversed Caster Housing							
Caster Size			4	5	6	6X2	8	8X2	4	5	6	6X2	8	8X2	
Composite Footrest	Front Seat to Floor Height	13													
		13½													
		14													
		14½													
		15													
		15½													
		16													
		16½													
		17													
		17½													
		18													
		18½													
		19													
		19½													
20															
Angle Adjustable Footrest	Front Seat to Floor Height	13													
		13½													
		14													
		14½													
		15													
		15½													
		16													
		16½													
		17													
		17½													
		18													
		18½													
		19													
		19½													
20															

	Seat height not available		No go with short stem		Available with short and long stem
--	---------------------------	--	-----------------------	--	------------------------------------

Seat Height - Casters

Caster Footrest Compatibility Matrix

80° Extension Mount Hangers

Caster Housing		Forward Caster Housing						Reversed Caster Housing					
Caster Size		4	5	6	6X2	8	8X2	4	5	6	6X2	8	8X2
Composite Footrest	Front Seat to Floor Height	13	■	■	■	■	■	■	■	■	■	■	■
		13½	■	■	■	■	■	■	■	■	■	■	■
		14	■	■	■	■	■	■	■	■	■	■	■
		14½	■	■	■	■	■	■	■	■	■	■	■
		15	■	■	■	■	■	■	■	■	■	■	■
		15½	■	■	■	■	■	■	■	■	■	■	■
		16	■	■	■	■	■	■	■	■	■	■	■
		16½	■	■	■	■	■	■	■	■	■	■	■
		17	■	■	■	■	■	■	■	■	■	■	■
		17½	■	■	■	■	■	■	■	■	■	■	■
		18	■	■	■	■	■	■	■	■	■	■	■
		18½	■	■	■	■	■	■	■	■	■	■	■
Angle Adjustable Footrest	Front Seat to Floor Height	19	■	■	■	■	■	■	■	■	■	■	■
		19½	■	■	■	■	■	■	■	■	■	■	■
		20	■	■	■	■	■	■	■	■	■	■	■
		13	■	■	■	■	■	■	■	■	■	■	■
		13½	■	■	■	■	■	■	■	■	■	■	■
		14	■	■	■	■	■	■	■	■	■	■	■
		14½	■	■	■	■	■	■	■	■	■	■	■
		15	■	■	■	■	■	■	■	■	■	■	■
		15½	■	■	■	■	■	■	■	■	■	■	■
		16	■	■	■	■	■	■	■	■	■	■	■
		16½	■	■	■	■	■	■	■	■	■	■	■
		17	■	■	■	■	■	■	■	■	■	■	■
17½	■	■	■	■	■	■	■	■	■	■	■		
18	■	■	■	■	■	■	■	■	■	■	■		
18½	■	■	■	■	■	■	■	■	■	■	■		
19	■	■	■	■	■	■	■	■	■	■	■		
19½	■	■	■	■	■	■	■	■	■	■	■		
20	■	■	■	■	■	■	■	■	■	■	■		

	Seat height not available		No go with short stem		Available with short and long stem
--	---------------------------	--	-----------------------	--	------------------------------------

Seat Height - Casters

Caster Footrest Compatibility Matrix

Direct Mount Hangers

Caster Housing		Forward Caster Housing						Reversed Caster Housing					
Caster Size		4	5	6	6X2	8	8X2	4	5	6	6X2	8	8X2
70°	Front Seat to Floor Height	13											
		13½											
		14											
		14½											
		15											
		15½											
		16											
		16½											
		17											
		17½											
		18											
		18½											
		19											
19½													
20													
80°	Front Seat to Floor Height	13											
		13½											
		14											
		14½											
		15											
		15½											
		16											
		16½											
		17											
		17½											
		18											
		18½											
		19											
19½													
20													
90°	Front Seat to Floor Height	13											
		13½											
		14											
		14½											
		15											
		15½											
		16											
		16½											
		17											
		17½											
		18											
		18½											
		19											
19½													
20													

	Seat height not available		No go with short stem		Available with short and long stem
--	---------------------------	--	-----------------------	--	------------------------------------

Seat Height - Caster Positioning within Caster Fork

To adjust the caster within the caster fork, use two 13mm wrenches to remove the bolt, two spacers (used on all except 8x2) and nut. Move everything to the correct hole and reinstall hardware to secure.

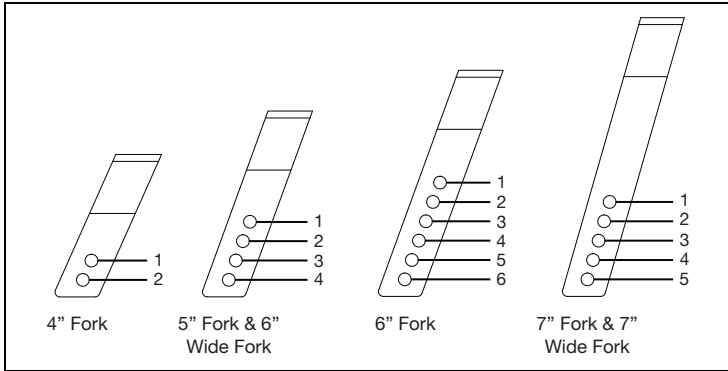

Fork Hole (Reference diagram above)			1	2	3	4	5	6
Caster	Fork	Stem	Seat Height					
4"	4"	Short	13	13.5				
		Tall	14.5	15				
	5"	Short		13.5	14	14.5		
		Tall		15	15.5	16		
5"	5"	Short		14	14.5	15		
		Tall		15.5	16	16.5		
	6"	Short			14.5	15	15.5	16
		Tall			16	16.5	17	17.5
	7"	Short		16	16.5	17	17.5	
		Tall		17	17.5	18	18.5	
6"	6"	Short			15	15.5	16	16.5
		Tall			16	16.5	17	17.5
	7"	Short	16	16.5	17	17.5	18	
		Tall	17	17.5	18	18.5	19	
6X2	6W	Short	15	15.5	16	16.5		
		Tall	16.5	17	17.5	18		
	7W	Short	16	16.5	17	17.5	18	
		Tall	17	17.5	18	18.5	19	
8"	7"	Short	17	17.5	18	18.5	19	
		Tall	18	18.5	19	19.5	20	
8X1.5	6"	Short				16.5	17	17.5
		Tall				17.5	18	18.5
	7"	Short	17	17.5	18	18	18.5	
		Tall	18	18.5	19	19.5	20	
8X2	7W	Short	17	17.5	18	18.5	19	
		Tall	18	18.5	19	19.5	20	

Seat Height - Axle Position

Based on your axle plate selection or type - use the following drawings and chart below to determine the vertical position of the axle plates to achieve desired rear seat height. A 13mm wrench is needed for the axle plate bolts.

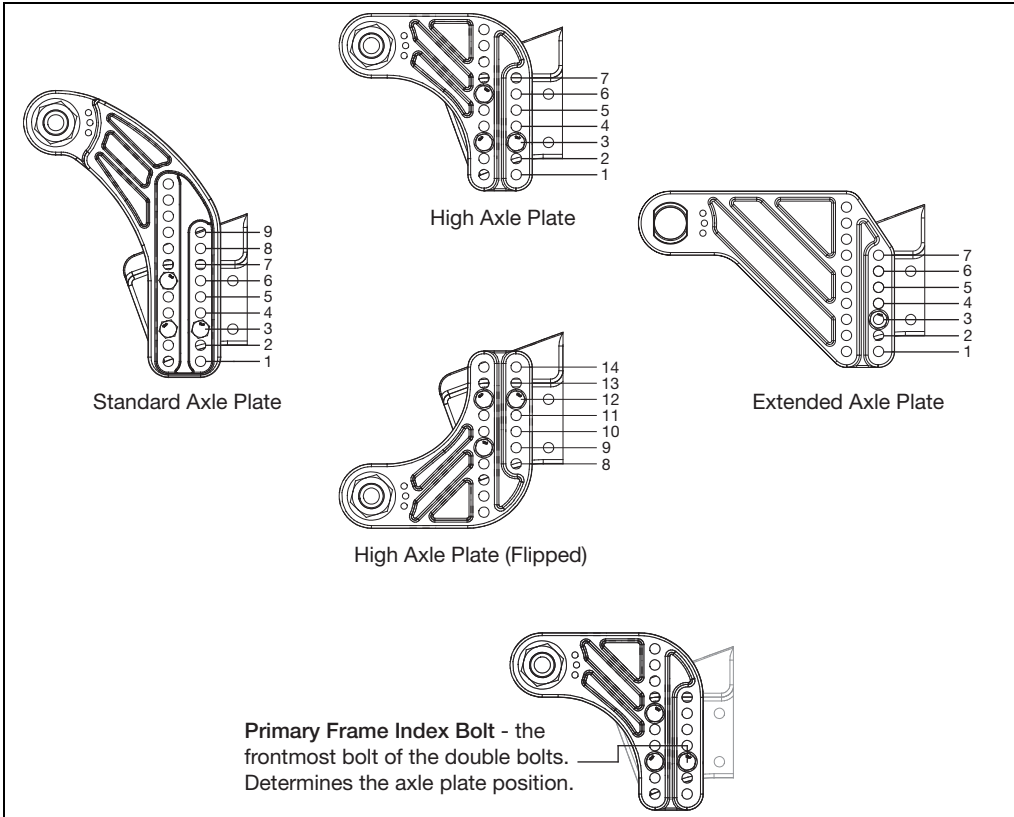

Wheel Size	High/Extended Axle Plate														Standard Axle Plate											
	1	2	3	4	5	6	7	8	9	10	11	12	13	14	1	2	3	4	5	6	7	8	9			
12 Poly			13	13.5	14	14.5	15	15.5	16	16.5	17	17.5	18	18.5												
12		13	13.5	14	14.5	15	15.5	16	16.5	17	17.5	18	18.5	19												
16 Low Poly	13.5	14	14.5	15	15.5	16	16.5	17	17.5	18	18.5	19	19.5	20												
16	14.5	15	15.5	16	16.5	17	17.5	18	18.5	19	19.5	20	20.5	21												
20 Low Poly	16	16.5	17	17.5	18	18.5	19	19.5	20	20.5	21							13	13.5	14	14.5	15	15.5	16	16.5	
20	16.5	17	17.5	18	18.5	19	19.5	20	20.5	21								13	13.5	14	14.5	15	15.5	16	16.5	17
22 Low Poly	17	17.5	18	18.5	19	19.5	20	20.5	21									13.5	14	14.5	15	15.5	16	16.5	17	17.5
22	17.5	18	18.5	19	19.5	20	20.5	21										14	14.5	15	15.5	16	16.5	17	17.5	18
24 Low Poly	17.5	18	18.5	19	19.5	20	20.5	21										14.5	15	15.5	16	16.5	17	17.5	18	18.5
24	18.5	19	19.5	20	20.5	21											15	15.5	16	16.5	17	17.5	18	18.5	19	

Seat Depth - Backrest

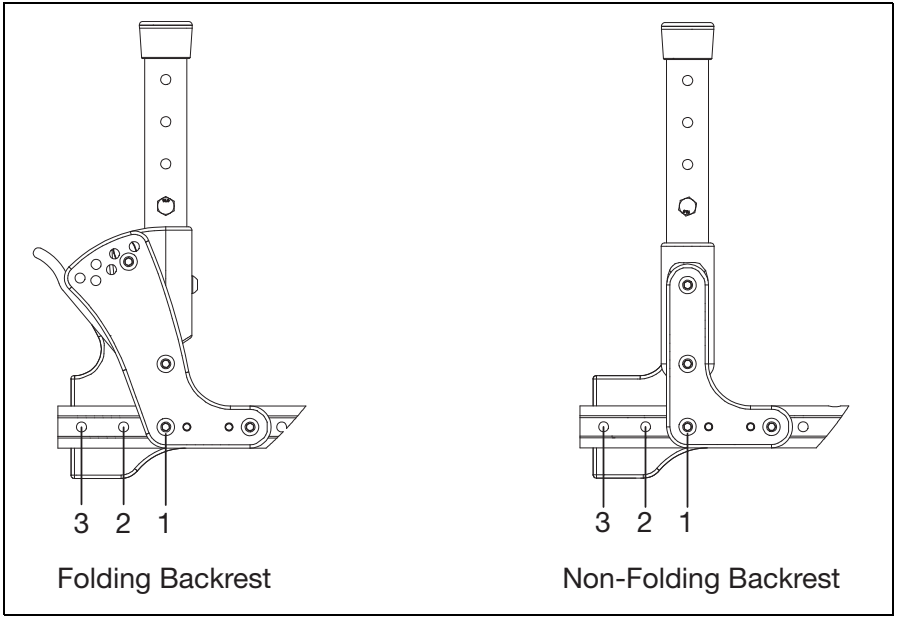

Seat Tube Length	Backrest Position	Seat Depth
Short	1	14
	2	15
	3	16
Medium	1	16
	2	17
	3	18
Long	1	18
	2	19
	3	20

Seat Depth - Axle Plate

Seat depth can be changed by repositioning the axle plate horizontally. Determine the horizontal positioning of the axle by using the desired seat depth, axle plate type and Center of Gravity offset within the drawing and matrix below.

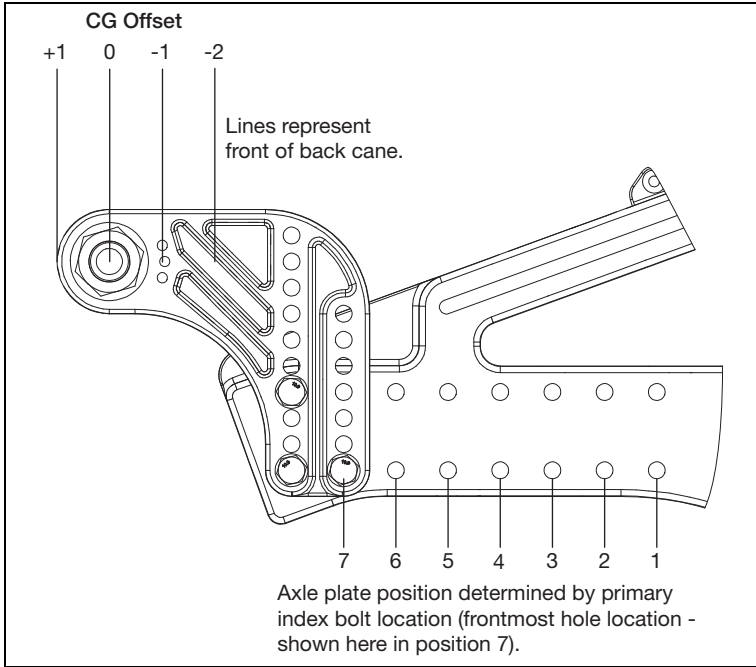

Axle Plate Style		Standard/High				Extended			
CG Offset		+1	0	-1	-2	+1	0	-1	-2
Seat Depth	14		1	2	3				1
	15	1	2	3	4			1	2
	16	2	3	4	5		1	2	3
	17	3	4	5	6	1	2	3	4
	18	4	5	6	7	2	3	4	5
	19	5	6	7		3	4	5	6
	20	6	7			4	5	6	7

Backrest - Back Height

Determine back post type and height and place on seat frame accordingly.

Back Post	Height Range	Back Height					
Stroller Handle Back Post	Short	20					
	Tall	24					
Height Adjustable Straight with Push Handle	Short	14	15	16	17	18	
	Medium	16	17	18	19	20	
	Tall	18	19	20	21	22	
Height Adjustable 8° Bend with Push Handle	Short	14	15	16	17	18	
	Medium	16	17	18	19	20	
	Tall	18	19	20	21	22	

Seat Width

Seat width is controlled by shortening or extending the length of the cross brace assemblies. Assemblies come in three sizes resulting in limited range per assembly. Determine the width required, confirm that the width is within the range of the assembly and relocate cross brace bolts to achieve the width desired.

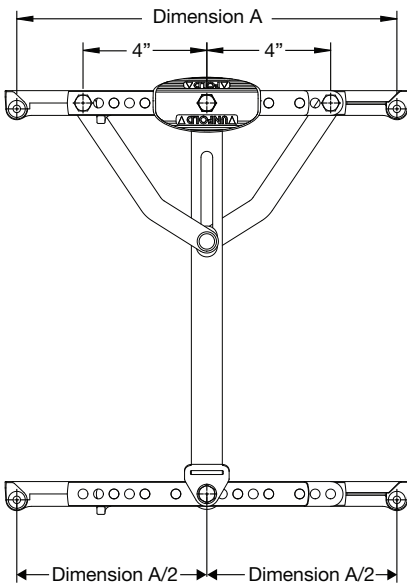

Upper and Lower Crossbrace Assembly

Size	Adjustment Range
Small	14" - 18"
Medium	16" - 20"
Large	18" - 22"

Chair Width	Dimension A	Dimension A/2
14	12.28	6.14
15	13.28	6.64
16	14.28	7.14
17	15.28	7.64
18	16.28	8.14
19	17.28	8.64
20	18.28	9.14
21	19.28	9.64
22	20.28	10.64

The hardware that needs to be removed to change the width are shown below. Use two 13mm wrenches on the front and rear lower braces. The rear upper cross brace hardware is removed using a 4mm Allen wrench and a 10mm wrench. Ensure each cross brace is set up with the same width configurations.

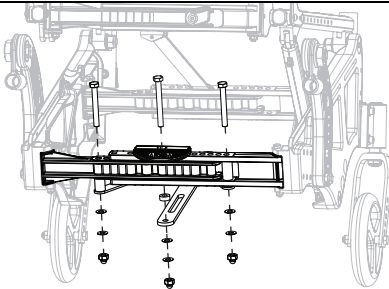

Rear Lower Cross Brace

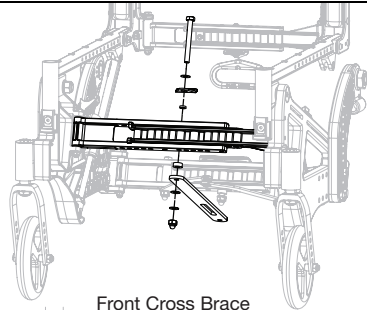

Front Cross Brace

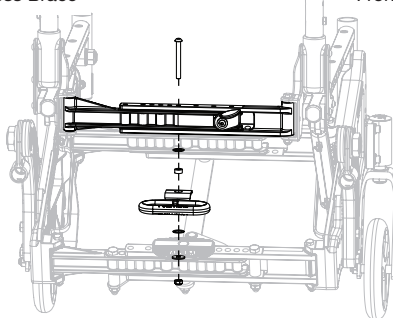

Rear Upper Cross Brace

Non-Folding Frame

The hardware and hole locations are different for a non-folding frame. See the image below for details. Two 10mm wrenches, two 13mm wrenches and a 5mm Allen wrench are needed.

NOTE: A non-folding frame does not have the locking tab, pull handle, foot pad or fold strap brackets.

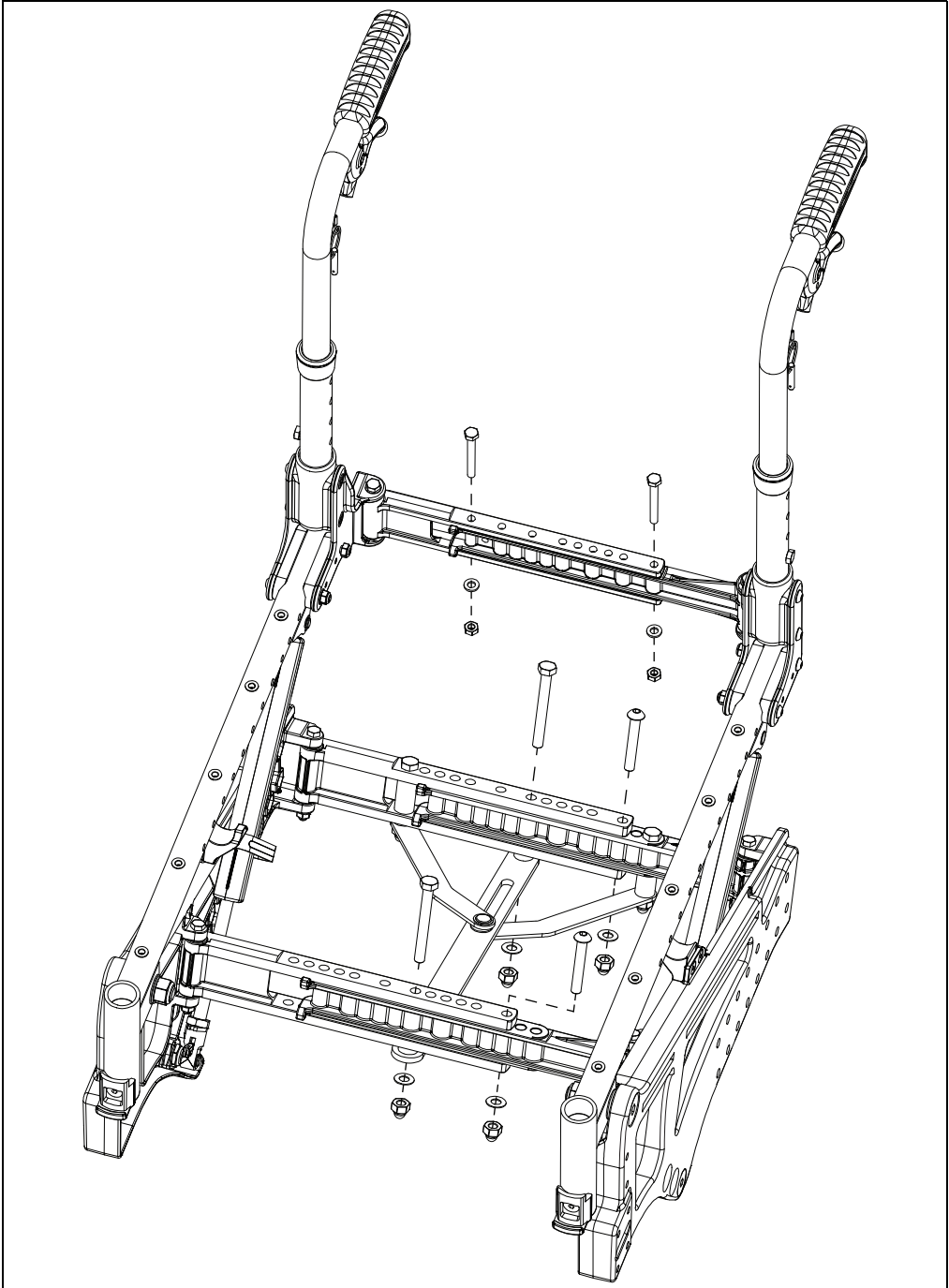

Axle Plate Construction

Use the diagrams below to assemble a Quick Release Axle or a Threaded Axle. Standard, extended and low axle plates are shown.

Quick Release Axle

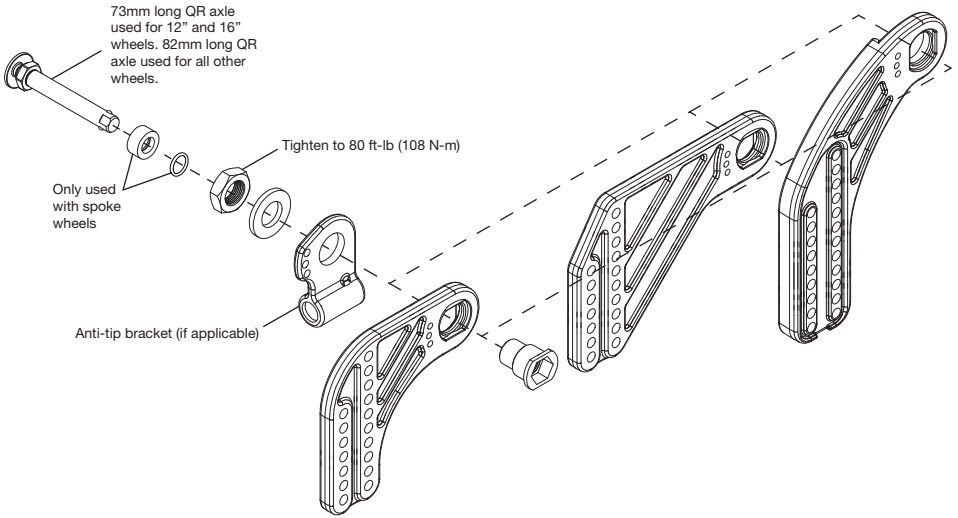

Threaded Axle

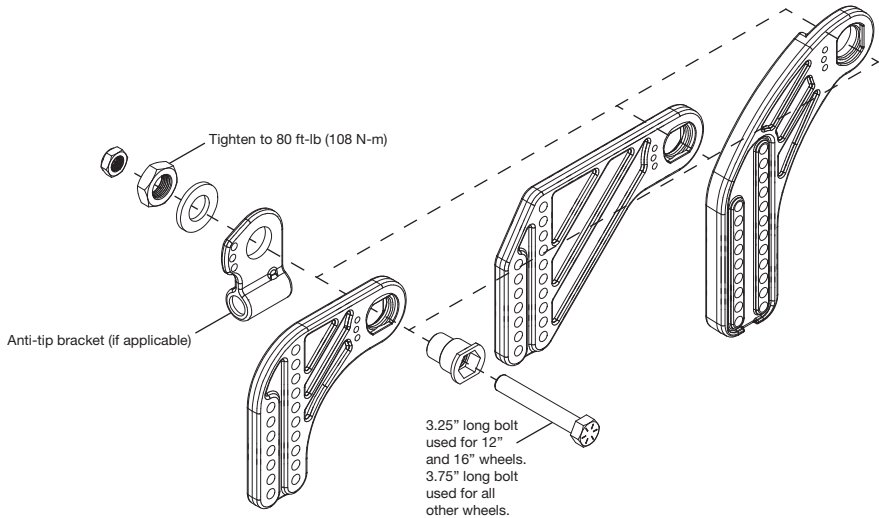

Caster Construction

Use the diagrams below to assemble a standard or a tall stem caster assembly. The caster assembly can be assembled in the forward or reversed configurations. Adjust the eccentric washers as needed to achieve the 90° to 92° angle dimension.

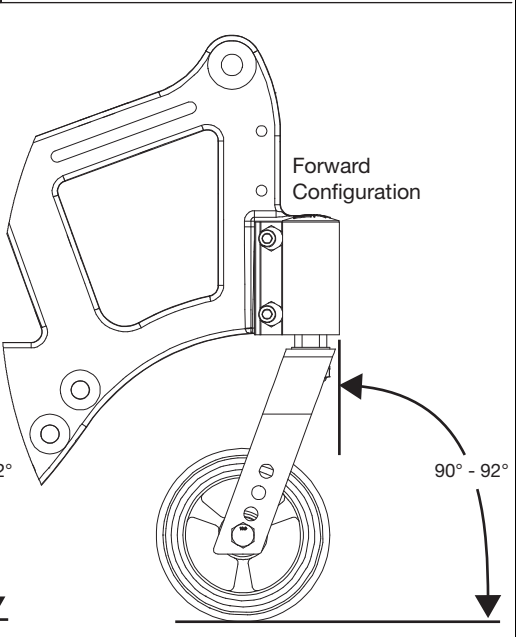
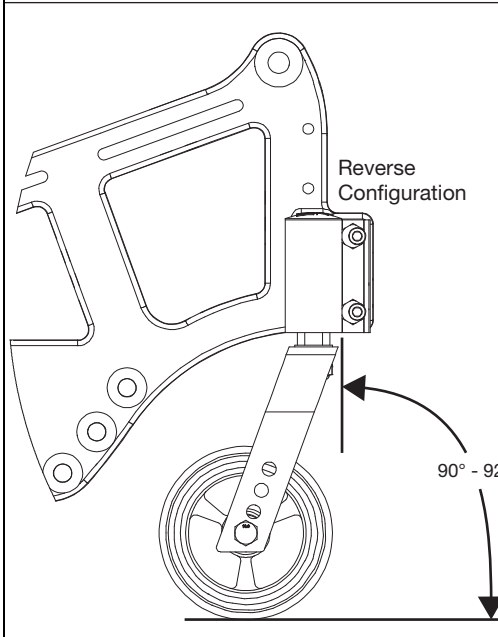
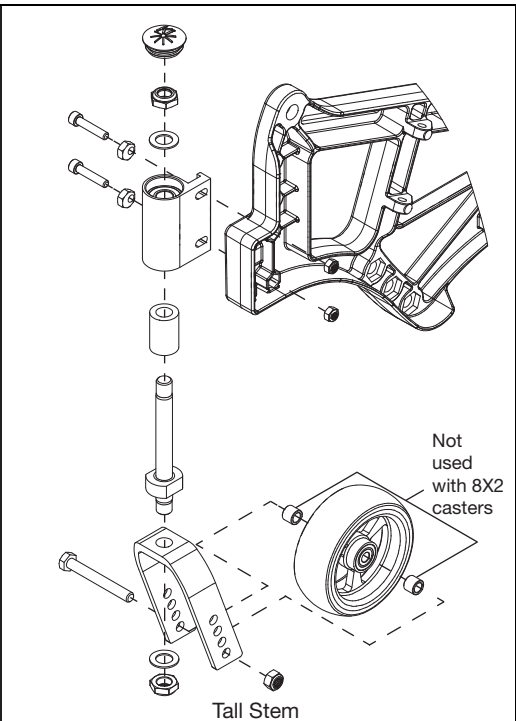
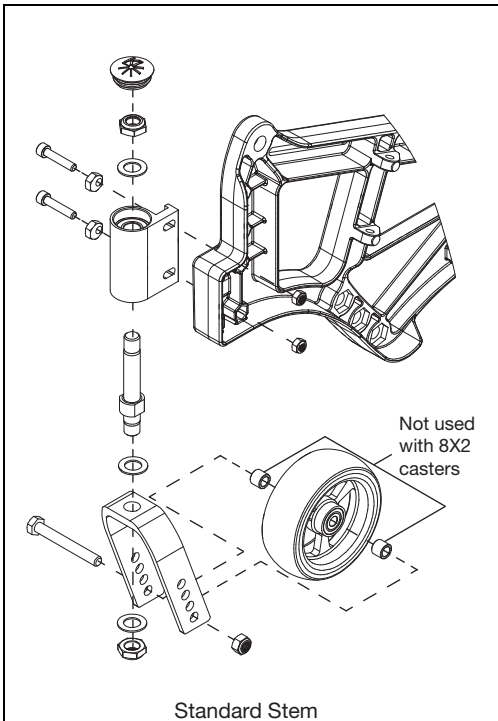

Fork and Stem Replacement

Remove Fork and Stem

1. Use a flat head screwdriver to remove the cap off of the caster barrel. Be careful not to scratch paint.

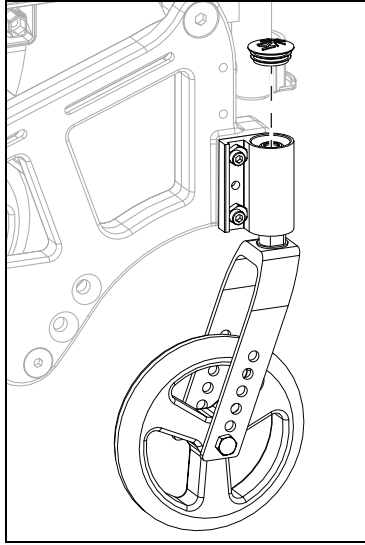

2. Use a 19mm socket wrench to remove the nut and washer from inside the caster housing. Hold the caster while removing the nut and washer.

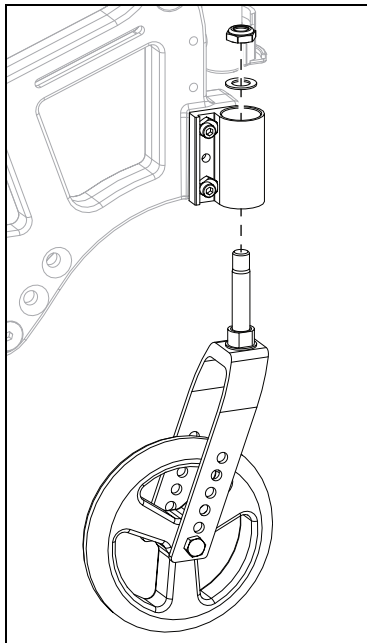

Fork and Stem Replacement

3. Remove the caster stem using a 19mm socket wrench on the bottom nut. Save all hardware and stem if you are not replacing the stem.

NOTE: The hardware on the stem of your chair may look different than what is shown below depending on the size of your fork and stem. The method of removing the stem is the same for all sizes.

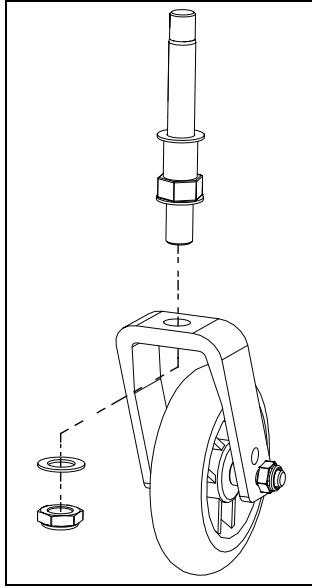

4. If you are replacing your forks, remove the bolt, nut and two spacers, per caster, using two 13mm wrenches.

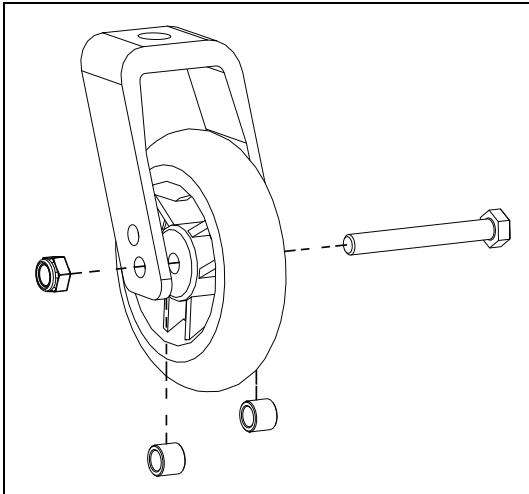

Fork and Stem Replacement

Install Fork and Stem

1. Install new fork onto caster with one bolt (A), one nut (B) and two spacers (C) per side using two 13mm wrenches. Standard forks use spacer 100792 (C) and wide forks use spacer 001246 (C). Also, a standard fork uses 101829 - M8 x 65 bolt (A) while a wide fork uses the longer 101709 - M8 x 80 bolt (A).

NOTE: Reference the Front Seat Height Matrix for reference on which forks and fork holes to use to achieve desired height.

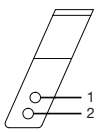

4" Fork

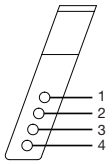

5" Fork & 6" Wide Fork

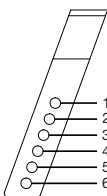

6" Fork

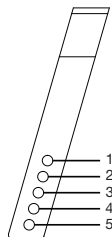

7" Fork & 7" Wide Fork

Front Seat Height Matrix										
Caster	Fork	Stem	Fork Hole							
			1	2	3	4	5	6		
4"	4"	Short	13	13.5						
		Tall	14.5	15						
	5"	Short		14	14.5	15				
		Tall		15	15.5	16				
5"	5"	Short		14	14.5	15				
		Tall		15.5	16	16.5				
	6"	Short			14.5	15	15.5	16		
		Tall			16	16.5	17	17.5		
	7"	Short		16	16.5	17	17.5			
		Tall		17.5	18	18.5	19			
6"	6"	Short			15	15.5	16	16.5		
		Tall			16.5	17	17.5	18		
	7"	Short	16	16.5	17	17.5	18			
		Tall	17	17.5	18	18.5	19			
6 X 2	6" Wide	Short	15	15.5	16	16.5				
		Tall	16.5	17	17	17.5				
	7" Wide	Short	16	16.5	17	17.5	18			
		Tall	17	17.5	18	18.5	19			
8"	7"	Short	17	17.5	18	18.5	19			
		Tall	18.5	19	19.5	20	20.5			
8 X 1.5	6"	Short				16.5	17	17.5	18	18.5
		Tall				17.5	18	18.5	19	
	7"	Short	17	17.5	18	18	18.5			
		Tall	18	18.5	19	19.5	20			
8 X 2	7" Wide	Short	17	17.5	18	18.5	19			
		Tall	18	18.5	19	19.5	20			

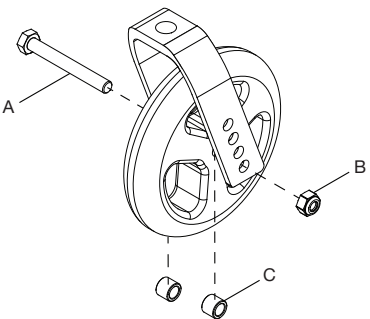

Fork and Stem Replacement

2. Install new stem or reinstall stem saved from Remove Fork and Stem, step 3. Install hardware based on the size stem you are using. Tighten the bottom nut (A) to 55 ft.- lbs. using the torque wrench.

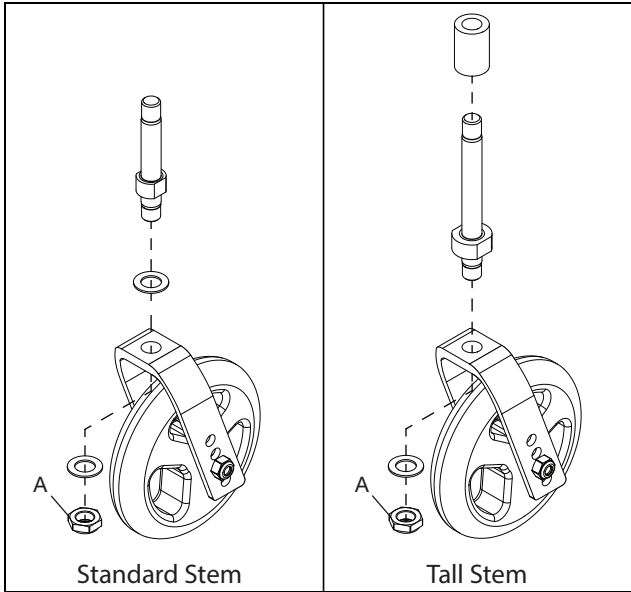

3. Secure stem and caster assembly in the caster housing using a washer (B) and nut (A). Tighten the top nut all the way and then back it off one quarter of a turn. Reinstall caster housing cover. Verify that the stem rotates freely and there is no vertical play. Last, reinstall cap on caster barrel.

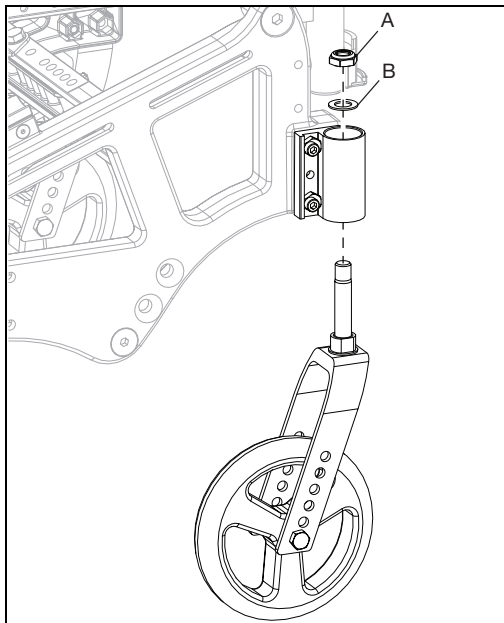

Wheel Pull Correction

NOTE: The direction of the pull determines which wheel will be adjusted to fix any wheel pull. If chair pulls left, fix the left caster wheel.

1. Remove cap on caster barrel.

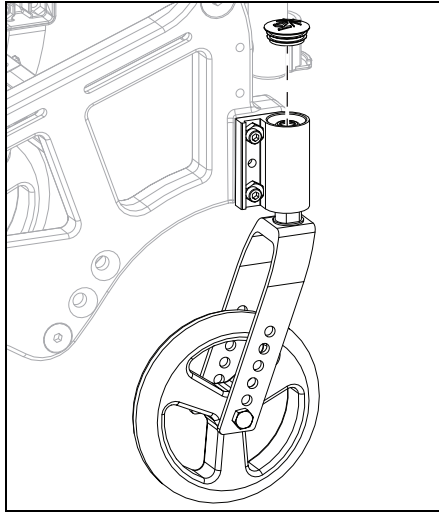

2. Use a 19mm socket wrench to remove the nut and washer from inside caster housing. Hold the caster while removing the nut and washer.

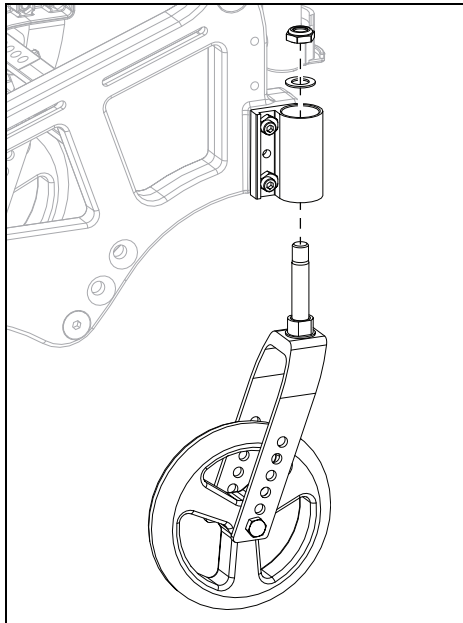

Wheel Pull Correction

3. Move the washer removed in step 2 to the bottom side of the caster barrel. Add another of the same washer to the bottom side of the caster barrel (washer is part #100682 - washer $\frac{1}{2}$ " .518 x .875 x 0.47 F/W Black Zinc). Install new caster assembly back together. Tighten the top nut all the way and then back it off one quarter of a turn. Reinstall caster housing cover. Verify that the stem rotates freely and there is no vertical play.

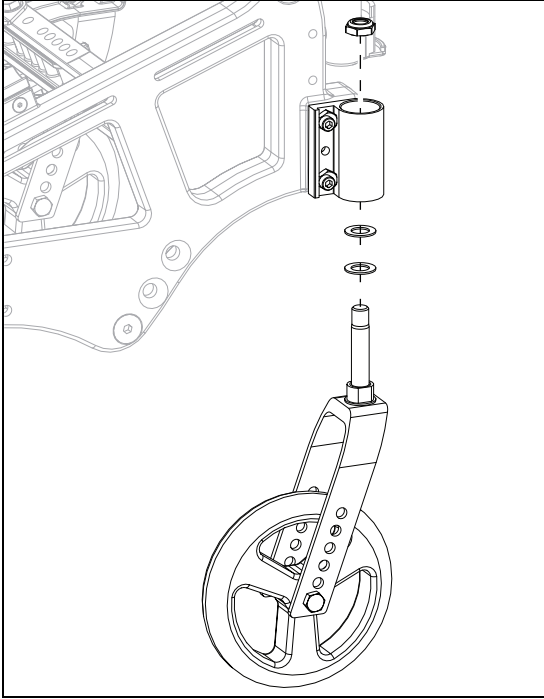

4. Reinstall cap on caster barrel.

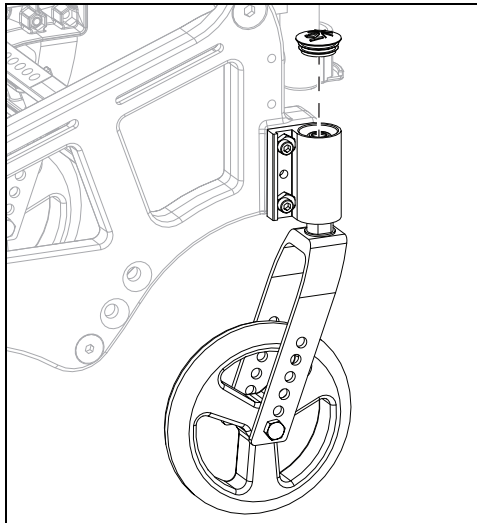

Adjusting Gas Springs

NOTE: Chair capacity is always 250 lbs. Adjustments may be made to change resistance/assistance of the tilt mechanism for the attendant.

NOTE: A gas spring location chart is located on the next page for reference if needed.

1. Remove E-Clip from lower end of the gas spring.
2. Remove cylinder mount screw with a 6mm Allen wrench.
3. Rotate gas spring, remove nut and place nut into the new desired location.
4. Reinstall cylinder mount screw through frame, gas spring and nut.
5. Reinstall E-Clip.

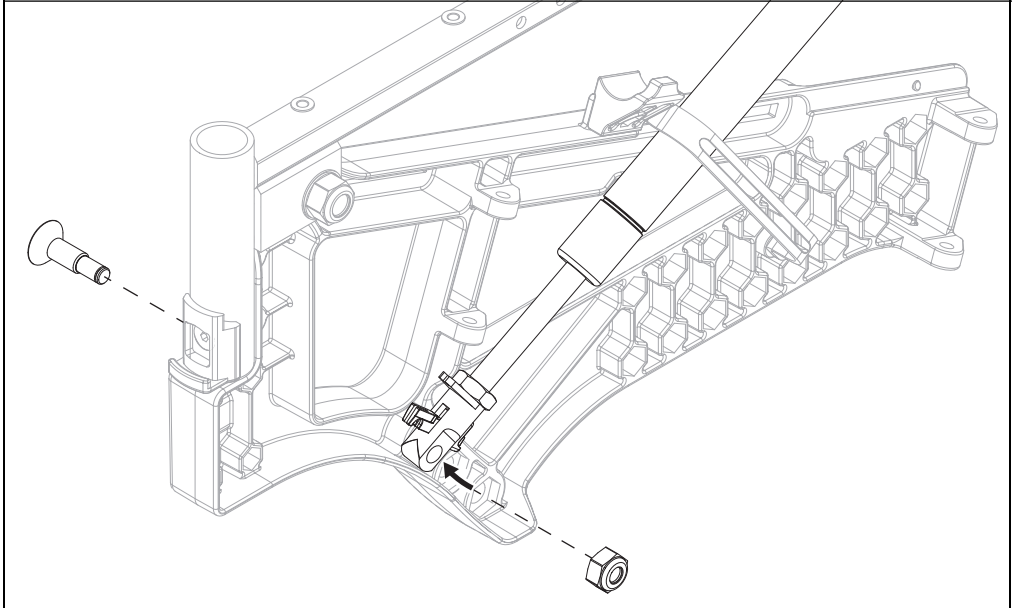
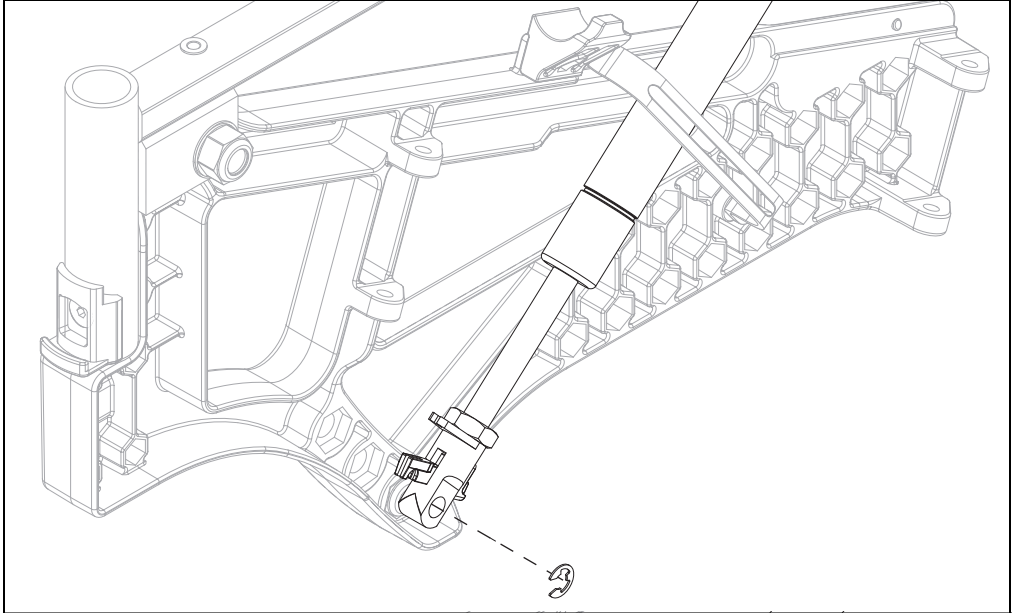

Replacing Gas Springs

Identify your current gas spring force (300N or 450N).

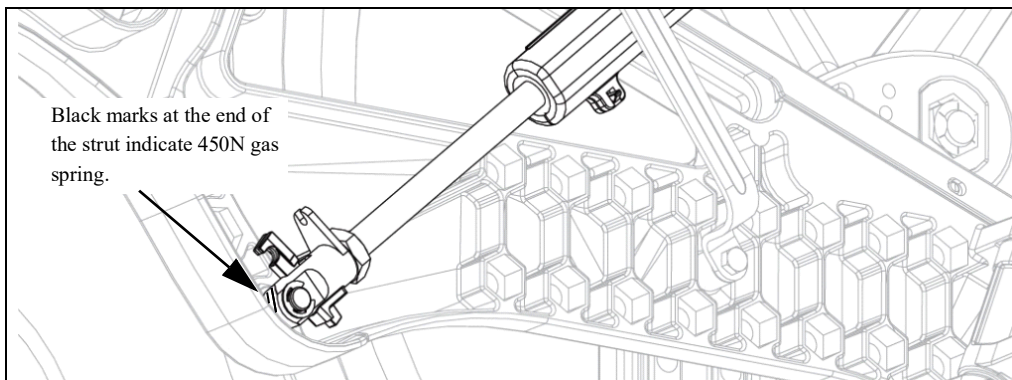

1. Remove current gas spring by removing a clevis pin, cylinder mount screw, nut and two E-Clips. Use a 6mm Allen wrench to remove the cylinder mount screw. Slide the gas spring out of the bracket.

NOTE: Bracket can be removed for easier access to gas spring if needed.

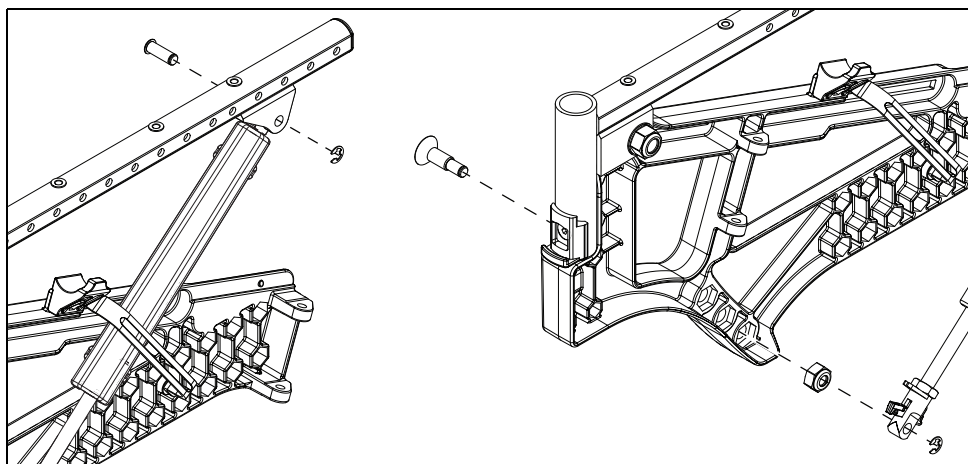

2. Ki Mobility recommends the following gas strut set-up for strut needed and configuration.

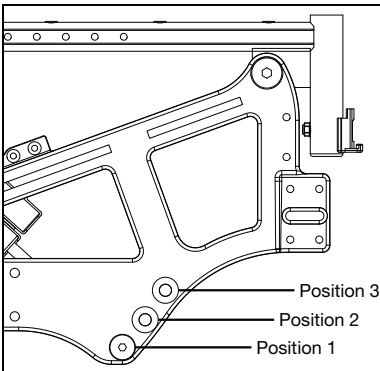

Gas Spring Locations

Assistive Gas Strut Set-Up		
Client Weight	Setting	Spring Type (Newtons)
> 200 lbs	1	450N
176 - 200 lbs	2	450N
151 - 175 lbs ¹	3	450N
151 - 175 lbs ²	1	300N
125 - 150 lbs	2	300N
< 125 lbs	3	300N
¹ Standard on chairs less than 16" deep		
² Standard on chairs 16" deep or larger		

3. Reinstall hardware.

Replacing Frame Cover

1. Remove current frame cover by removing nut using an 8mm wrench and a 3mm Allen wrench.

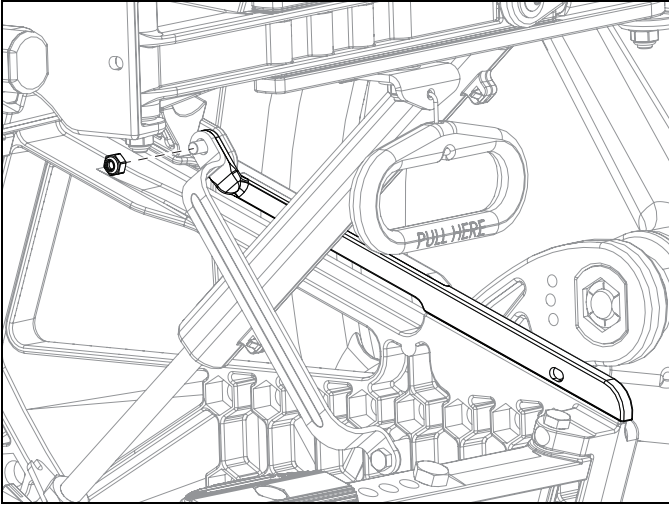

2. Separate and roll back tape backing (red) (B) from adhesive with blade on the inside of the new cover (A).

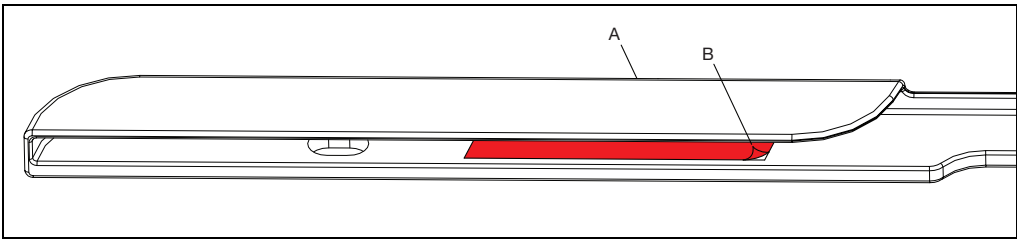

3. Discard red tape backing.
4. Install new frame cover (C) with nut (A) using an 8mm wrench and a 3mm Allen wrench. Ensure the higher end goes underneath the gas spring guard (B) attachment point.

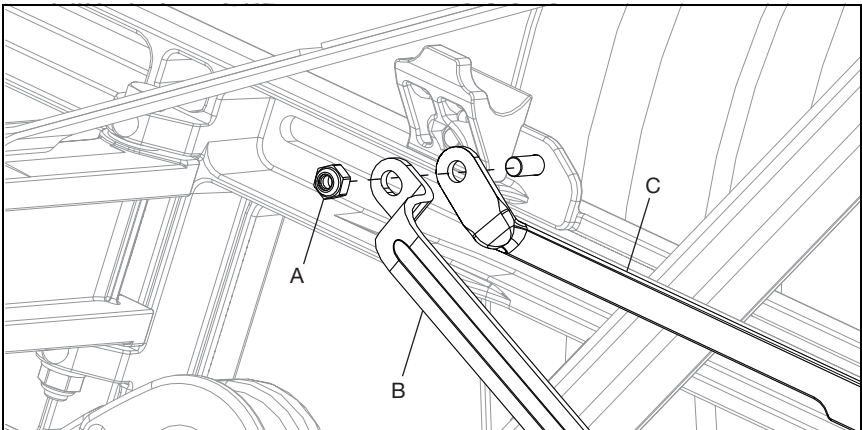

5. Repeat steps on opposite side.

Fold Lever Replacement

NOTE: For easier access to parts involved in this instruction, remove any backrest and/or seat upholstery before beginning.

1. Remove the existing fold lever assembly by removing hardware and fold lever using a 3mm Allen wrench and an 8mm wrench.

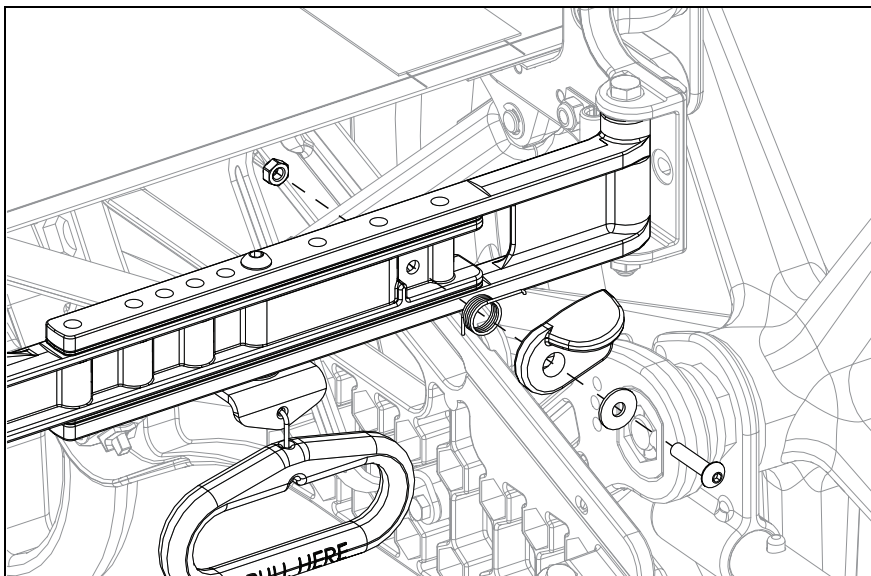

2. Put washer (C), fold lever (B), and spring (A) onto screw (D) in the sequence shown below.

NOTE: Spring is orientated in the back of the fold lever so the long arm tucks into the molded guard on the lever.

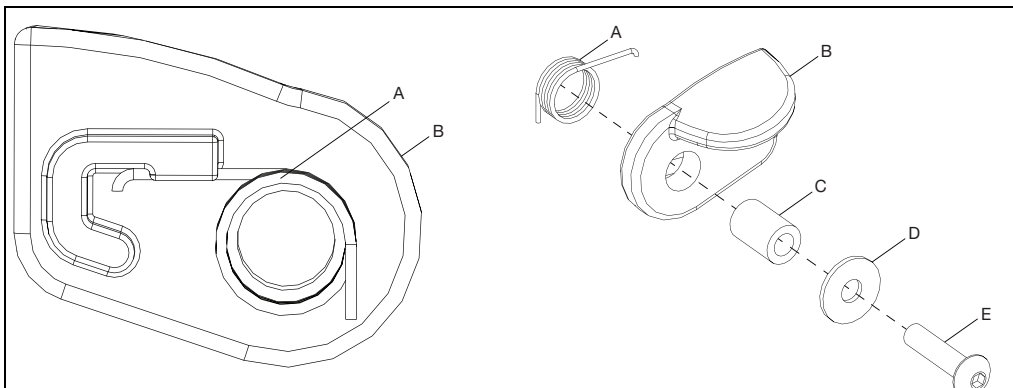

Fold Lever Replacement

3. Install the lever upside down with pressure. Maintain the pressure as you rotate the lever 180° and secure the nut using a 3mm Allen wrench and an 8mm wrench.

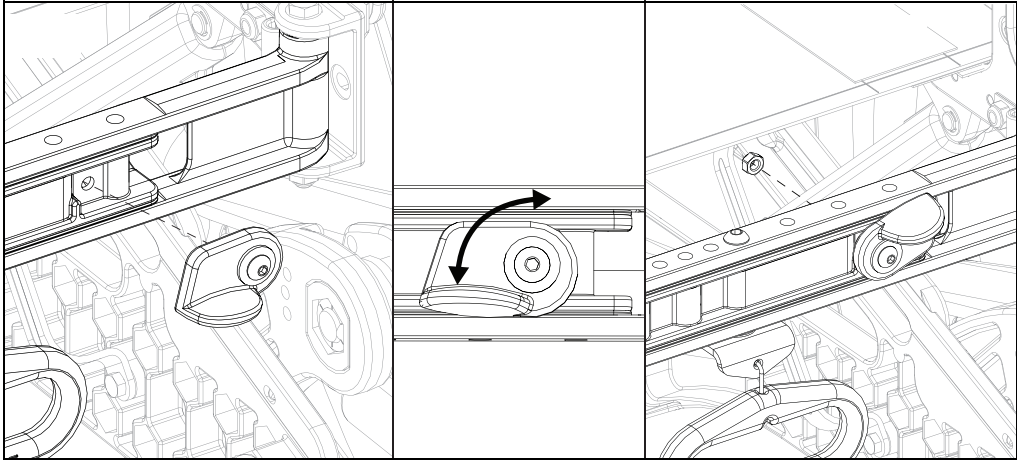

4. Test the fold lever assembly by two ways. First, look at the fold lever compared to the cross brace. The fold lever should be parallel to the cross brace. If incorrect, one end of the fold lever will be either closer or further away from the cross brace than the other end. Second, fold and unfold chair ensuring that fold lever releases and then locks back into place when cross braces are aligned.

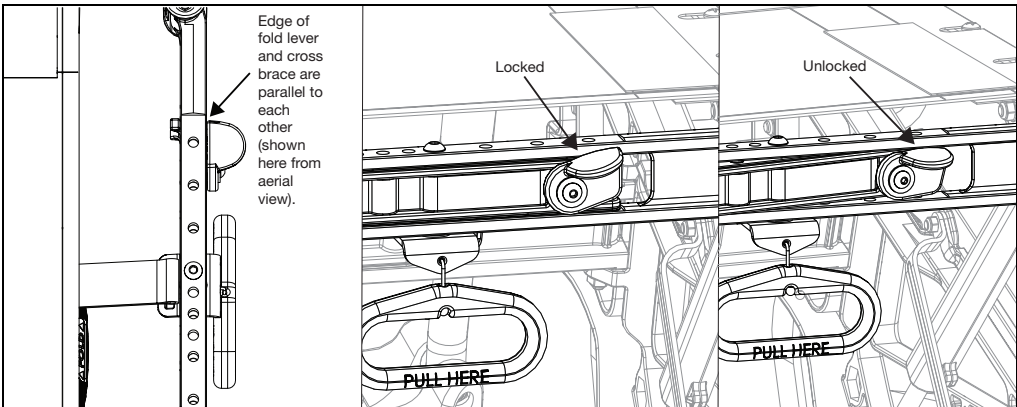

Adjusting Depth

1. If the seat depth adjustment is needed, remove bolts, washer, P-Clip and nuts using a 4mm Allen wrench and a 10mm wrench.

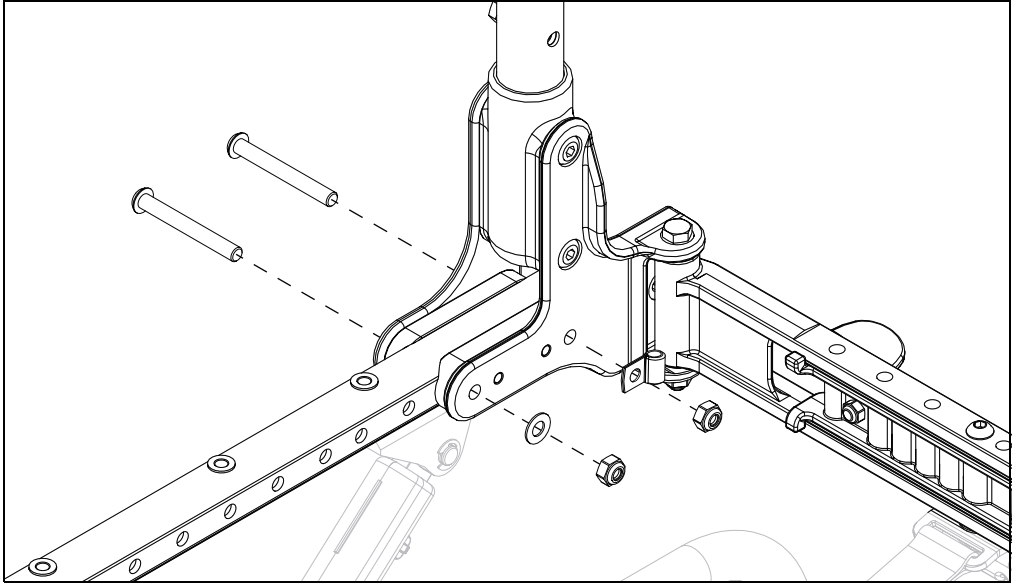

2. Use the chart and diagram below to find correct primary backrest bolt position.

Folding Backrest

Standard Backrest

Backrest position is determined by the primary backrest bolt.

Short Seat Tube	16	15	14		16	15	14
Medium Seat Tube	18	17	16		18	17	16
Long Seat Tube	20	19	18		20	19	18

3. Secure backrests in desired depth location by reinstalling hardware.

Changing Seat Sling

1. Remove seat sling by removing screws using a Phillips screwdriver.
2. Install seat rails into pockets on both sides of new seat sling.
3. Fold chair in part way. Install new seat sling and rails onto chair using a Phillips screwdriver. Do not tighten hardware. See the diagram and chart below.
4. Expand chair fully. Tighten all seat sling hardware and return chair to level position.

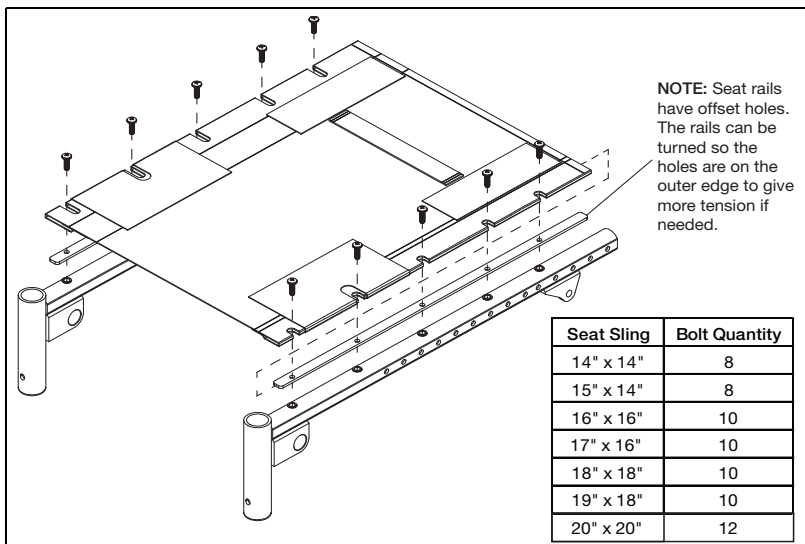

Changing Seat Rail

1. Remove any upholstery and backrest.
2. Detach gas spring from seat rail by removing clevis pin and E-Clip.

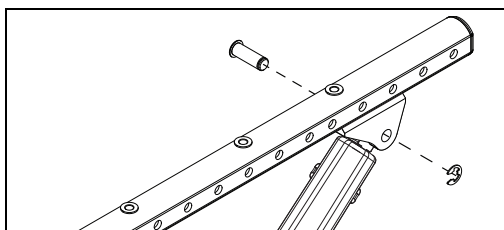

3. Remove seat rail from frame by removing bolt, pivot bushing, washer, and nut using a M8 Allen wrench and a 19mm wrench.

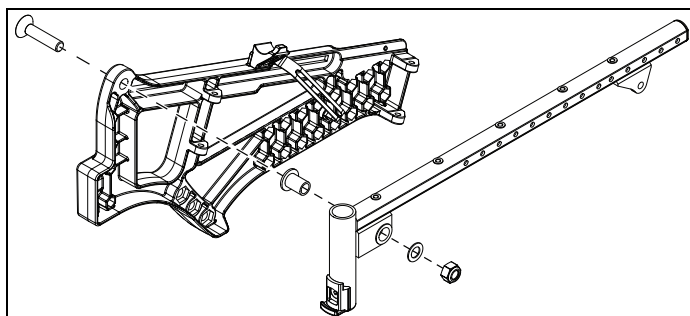

4. Install new seat rail using the hardware from step 3.

Changing to a Short Back

NOTE: Have chair in level position, not in any degree of tilt, while changing to a short back. This will help when working with the tilt cable in later steps.

1. Remove levers from back canes using a Phillips screwdriver. Save hardware.

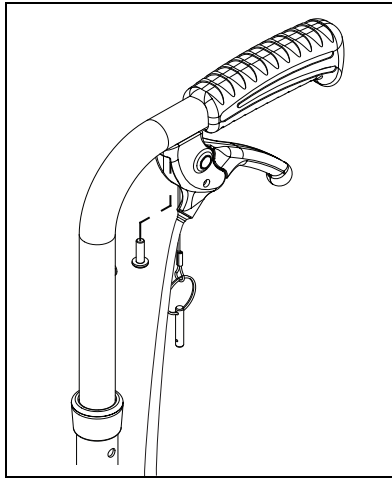

2. Remove both upper back cane tubes, at the same time, by removing the bolts using a 10mm wrench.

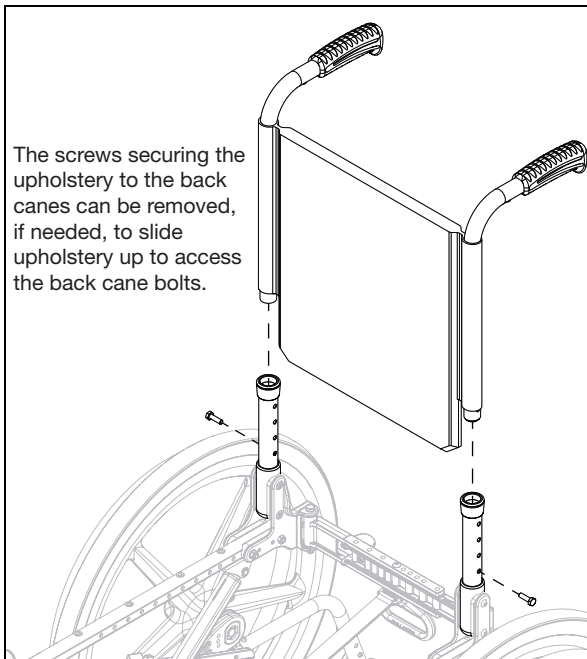

3. Install upholstery onto new back canes.
4. Install new short back cane tubes, in the height configuration desired, and secure with the bolts from step 2 using a 10mm wrench.
5. Install tilt lever onto back cane with hardware from step 1 using a Phillips screwdriver.

Changing to a Short Back

6. Ensure cable is routed correctly while chair is in a level position. See image below for correct routing.

NOTE: Ensure that cable is not pulled tight into the P-Clip on the back plate. Slack is needed between the cable connection point at the gas spring and the P-Clip to prevent damage during tilting. Also, verify there are no kinks or sharp turns in the cable.

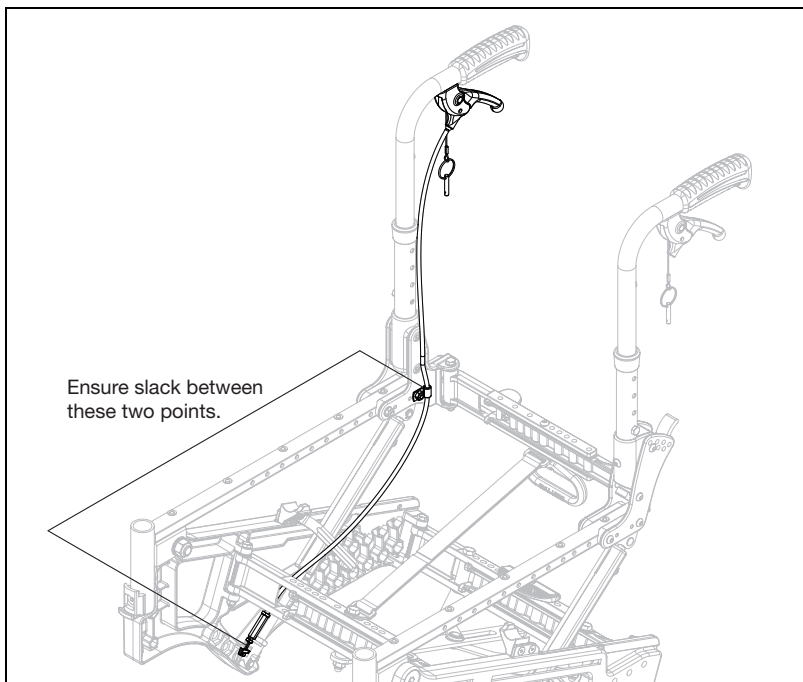

7. Ensure tilt function works correctly, if not, an adjustment is needed. Continue to next step for adjustment instructions.

8. Remove slack from tilt lever cable by adjusting the turnbuckle adapter. Verify the lever engages and tilts properly. After adjusting cables, tighten both adjustment nuts to secure.

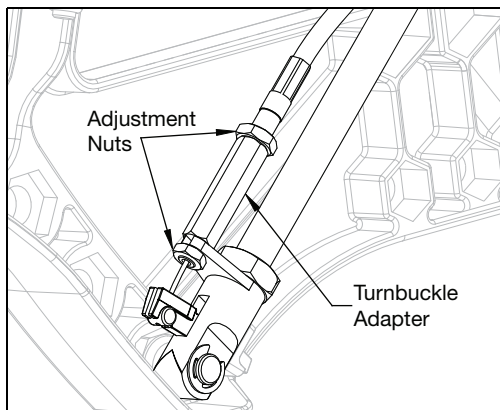

Replacing Tilt Cables

NOTE: Have chair in level position, not in any degree of tilt, while replacing cables.

1. Loosen adjustment nuts and remove cable from chair up to the trigger handles.

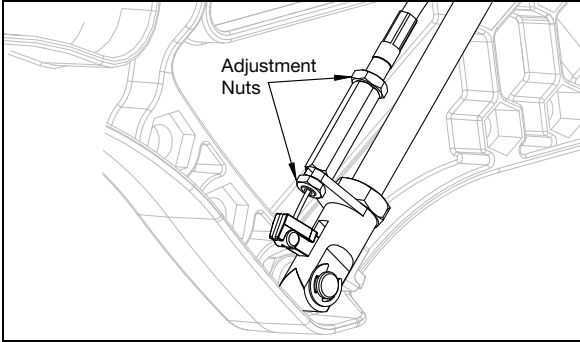

2. Pull cable out of lever channel, squeeze trigger and slide cable barrel out of trigger to remove cable.

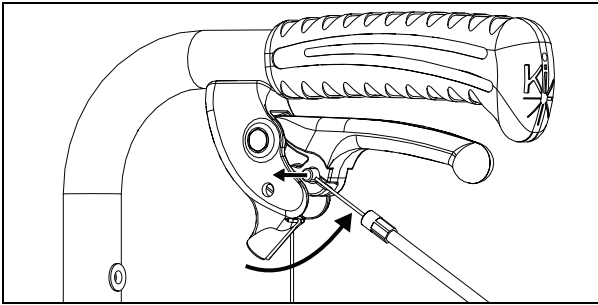

3. See chart and diagram below for information about tilt cable selection.

Cable Identification
Cable Length

A diagram of a cable with arrows at both ends indicating its length.

Cable Name	Length (inches)
Short	34.25"
Medium	36.25"
Long	38.25"
XL	40.25"
XXL	42.25"
XXXL	44.25"

Cable Lengths			
Backrest Type	Seat Rail Size		
	Short (14 - 16)	Medium (16 - 28)	Long (18 - 20)
Height Adjustable - Short	003288 Short	003289 Medium	003290 Long
Height Adjustable - Medium	003289 Medium	003290 Long	003291 XL
Height Adjustable - Tall	003290 Long	003291 XL	003292 XXL
Fixed Height - Standard	003289 Medium	003290 Long	003291 XL
Fixed Height - Tall	003291 XL	003292 XXL	003293 XXXL

4. With chair level, install cable onto chair and leave adjustment nuts loose.

Replacing Tilt Cables

5. Install cable into lever. Ensure cable is routed correctly. See correct routing below.

NOTE: Verify there are no kinks or sharp turns in the cable. P-Clip is installed after adjustments.

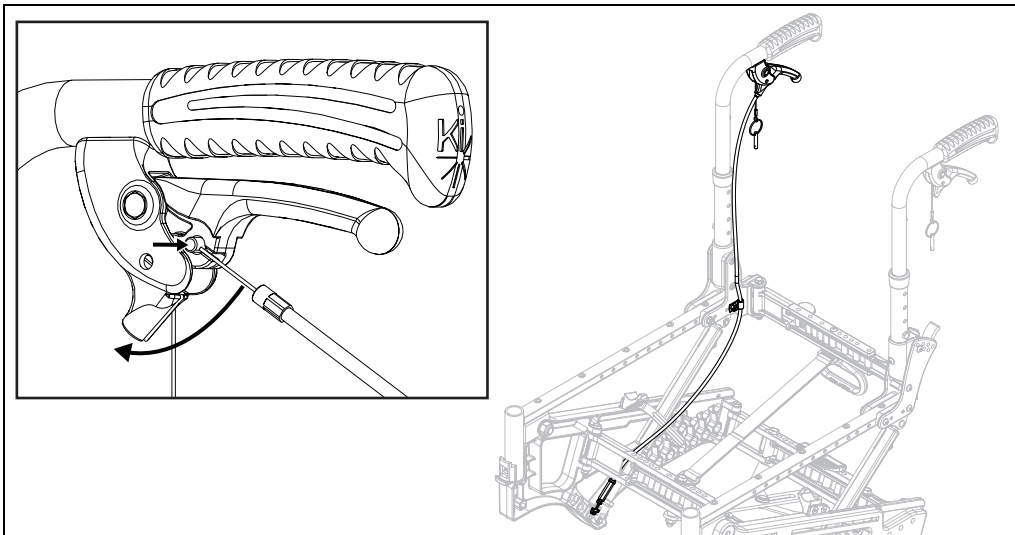

6. Remove slack from tilt lever cable by adjusting the turnbuckle adapter. Verify the lever engages and tilts properly. After adjusting cables, tighten both adjustment nuts to secure.

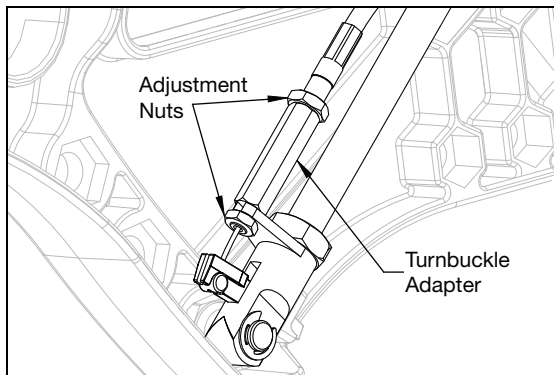

7. Secure cable to back plate with P-Clip using a 10mm wrench. Ensure that cable is not pulled tight into the P-Clip on the back plate. Slack is needed between the cable connection point at the gas spring and the P-Clip to prevent damage during tilting.

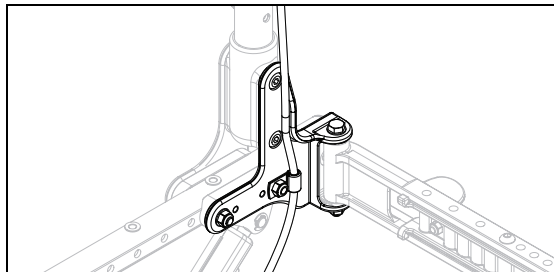

8. Repeat on opposite side.

Installing Transit

1. Install front transit bracket with two screws, two washers and two nuts using a 4mm Allen wrench and a 10mm wrench.
2. Install front transit hook label in the space between the two ends of the front transit bracket.

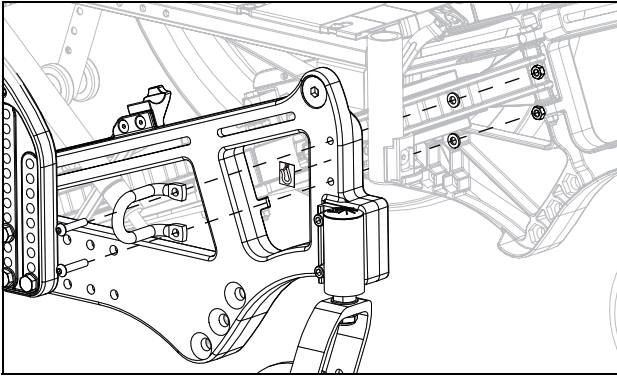

3. Remove outer back plate from both sides of chair using two 4mm Allen wrenches for the top two screws and a 4mm Allen wrench and 10mm wrench for the lower two bolts.

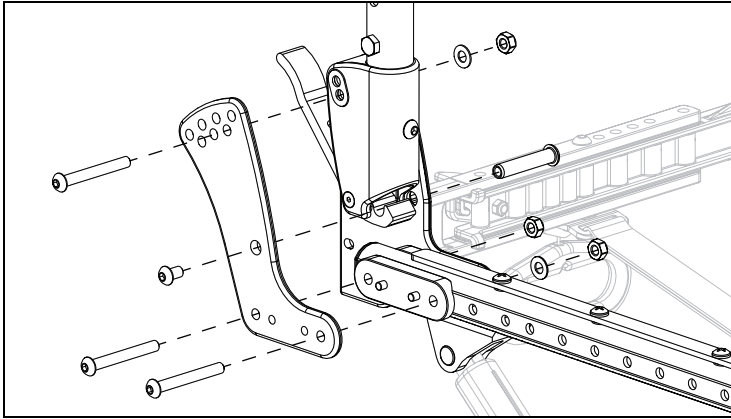

4. Install transit outer back plates and secure with hardware.
5. Install WC/19 transit labels on the inner back plates. The WC/19 transit label should be seen from the outside of the chair. Also, install the transit hook labels on the back plate near the transit loop.

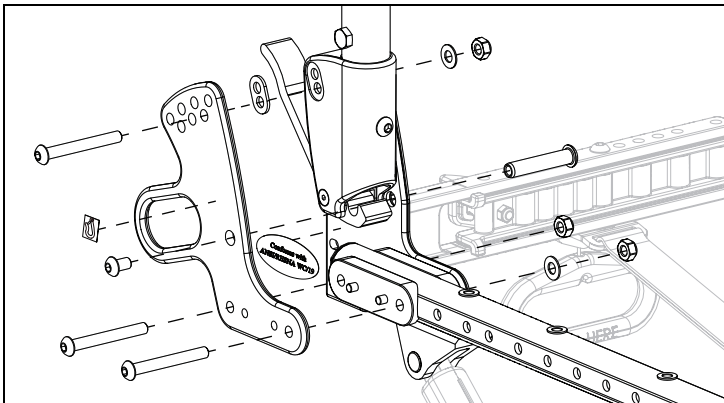

Wheel Lock Configurations

1. Use diagrams and charts to determine the needed wheel lock configuration for your chair.
2. Install wheel lock according to the configuration desired, determined from diagrams and chart below, using a 10mm wrench.

NOTE: Always mount carriage bolts as far apart as possible to maximize rigidity.

NOTE: Always loosen and tighten wheel lock hardware by alternating between the two bolts while loosening/tightening a little at a time. This prevents overclamping on one set of hardware which can lead to binding of the fasteners and increased difficulty in removal.

3. Test the wheel locks. Ensure wheel locks lock into place and tires do not move or slide when both wheel lock are engaged.

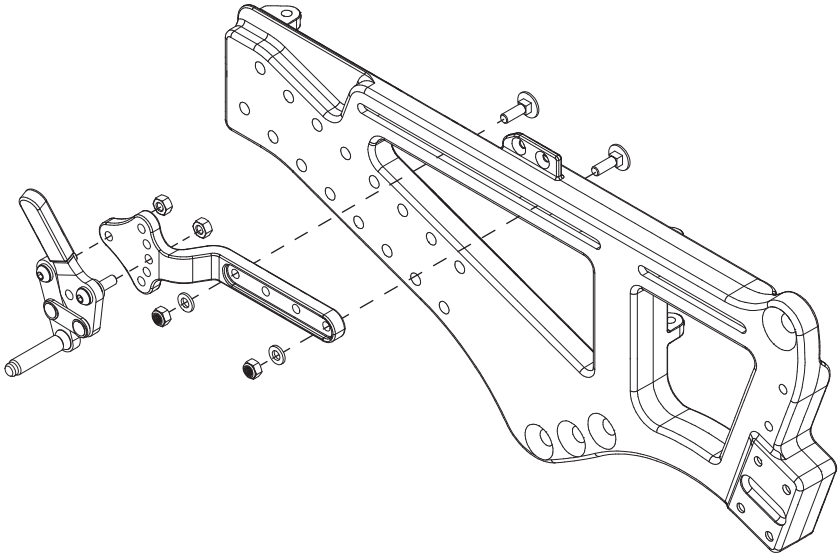

Adjust wheel lock angle so that Line A is as close as possible to Line B, but never below it.

Line A - Line between wheel lock mounting screws.
Line B - Line between front wheel lock screw and center of wheel.

Line A
Line B

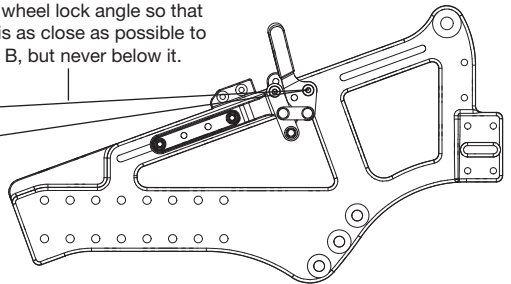

Wheel Lock Mount Configuration		
Wheel Size	STD/High Axle Plate	Extended Axle Plate
12	Reverse	Reverse
16	Reverse	Reverse
20	Forward	Reverse
22	Forward	Reverse
24	Forward	Forward

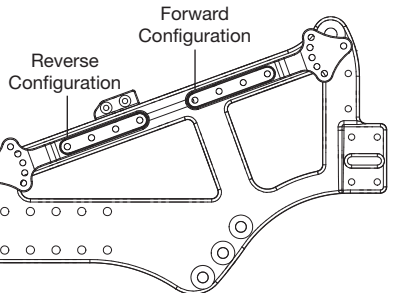

Handrim Configurations

NOTE: Not all wheels listed below are available for specific models. See an order form or the online parts manual for more information on your specific chair model.

Handrim Hardware Chart														
Wheel		Handrim Connection				Handrim								
Wheel	Wheel Part Number	Connection Points	Tab	Spacer	Screw	Aluminum Anodized	Superlight	Plastic Coated	Projection	Natural Fit Standard	Natural Fit LT	Flex Rim		
18" Ki Spoke	200529	3	100698	100653	Aluminum, Plastic Coated, Projection: 100654 Natural Fit: 100835	100206		101106						
20" Ki Spoke	200530					200536		200542						
22" Ki Spoke	200531					100560		100576	100569	200538	200201			
24" Ki Spoke	200532					200349		100577	200547	100793	200202			
25" Ki Spoke	200533					200350		101870	200548	200539	200540			
26" Ki Spoke	200534					200351		100578	200549	100907	101454			
24" Superlight	101159	6			100536	100754	101161	100836		100830	100828			
25" Superlight	101160					101197	101160	101091		101464	101460			
20" 5-Spoke X Core	101961	5		Aluminum, Projection, Natural Fit: 100629	100724	101897		101963						
22" 5-Spoke X Core	101962					Plastic Coated: 101756	101898		101964					
24" 5-Spoke X Core	100960			100975				100976	200546					
24" 5-Spoke X Core	100960				101893				100768	100769				
20" Spinergy Spox	See Spinergy Spox Page	6			Screw: 100669 Nut: 100657	103125		103179						
22" Spinergy Spox						100827		100808		100889	100888			
24" Spinergy Spox						100766	101161	100615		100830	100828			
25" Spinergy Spox						100767	101160	100765		101464	101460			
26" Spinergy Spox						101477		101148		200200	100950			
22" Spinergy LX	See Spinergy LX Page	6			Screw: 100669 Nut: 100657	100827		100808		100889	100888			
24" Spinergy LX						100766	101161	100615		100830	100828	200213		
25" Spinergy LX						100767	101160	100765		101464	101460	200208		
26" Spinergy LX						101477		101148		200200	100950			
24" Red Topolino	105045	6			Screw: 100669 Nut: 100657	100754	101161	100836		100830	100828			
24" Yellow Topolino	105046					100754	101161	100836		100830	100828			
25" Red Topolino	105047					101197	101160	101091		101464	101460			
25" Yellow Topolino	105048					101197	101160	101091		101464	101460			

Handrim Construction

The sequencing of hardware for the three styles of handrims is shown below. The specific hardware used is determined in the chart on the previous page, based on the tire and handrim being used.

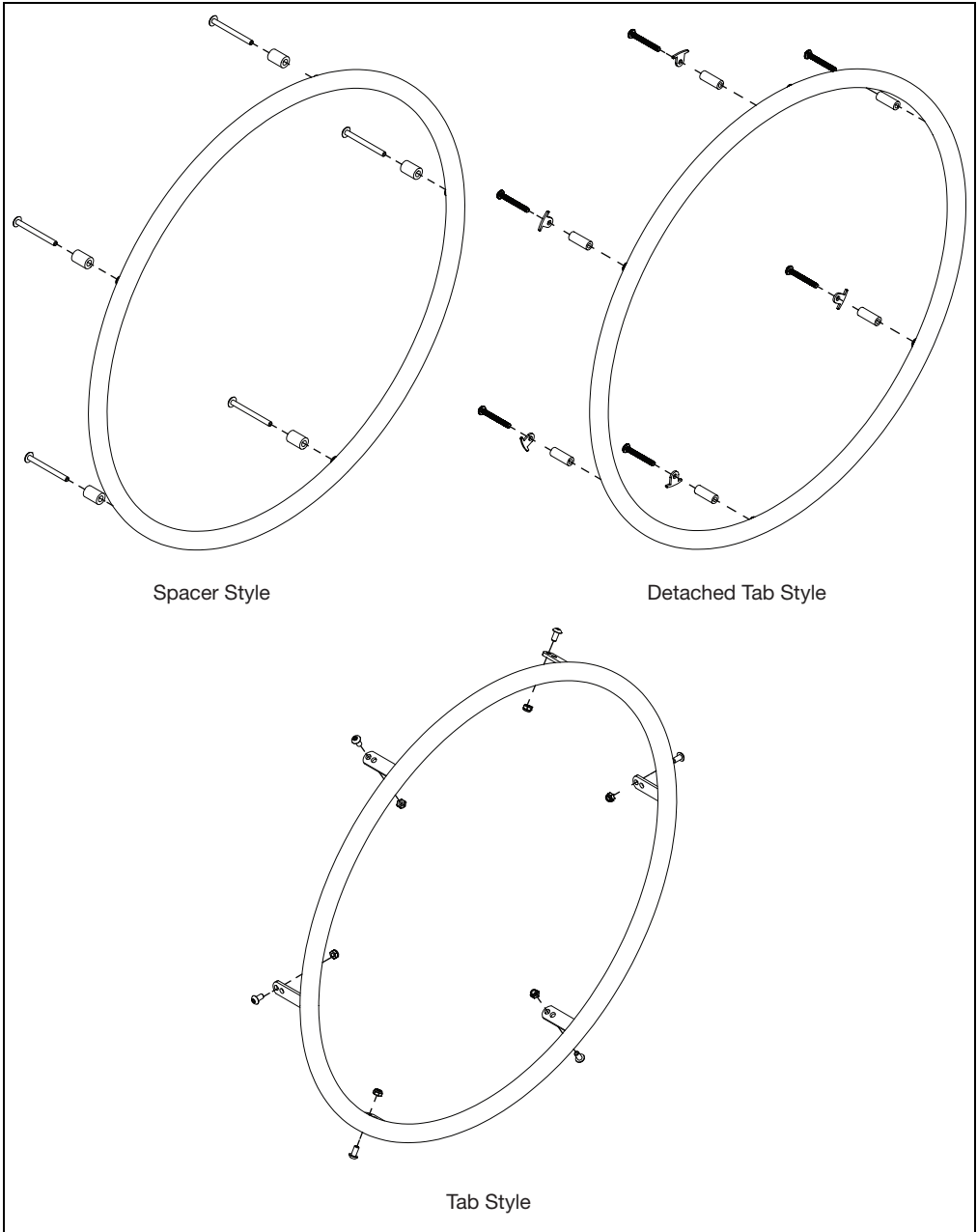

Footplate and Heel Loops

For additional footplate information, see pages 3 - 5 for the Caster - Footplate Compatibility Charts.

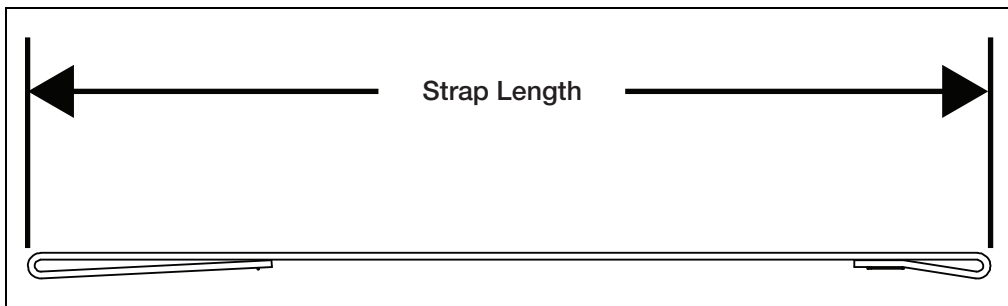

Heel Loop								
Size	Part Number	Standard Hanger			Offset Hanger			Strap Length
		Angle Adjustable	Composite	Composite Angle Adjustable	Angle Adjustable	Composite	Composite Angle Adjustable	
Short	100591	N/A	14" - 15"	N/A	N/A	N/A	N/A	9.4"
Medium	100592	14" - 15"	16" - 17"	15" - 16"	N/A	14" - 15"	15" - 16"	10.4"
Long	100593	16" - 22"	18" - 22"	17" - 22"	16" - 22"	16" - 22"	17" - 22"	11.4"

Pro ELR Adjustment

NOTE: Instructions for adjusting the height of the calf pad, the depth of the calf pad and the length of the footrest can be found in the owner manual in the Pro Elevated Leg Rest section.

Adjusting Knee Height

1. Using two 10mm socket wrenches, loosen the two nuts (A) on the cover.
2. Adjust knee height to desired setting.
3. Retighten the two nuts (A) after desired height is attained.

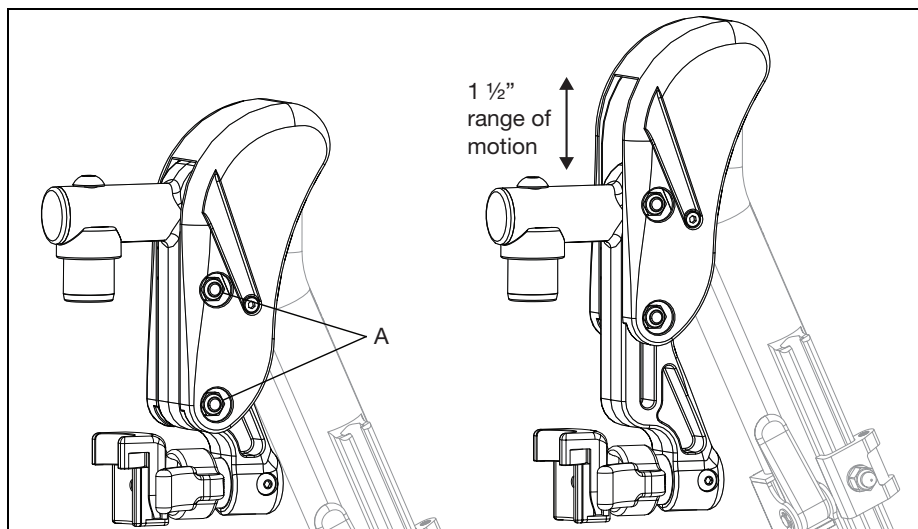

Rotating 4-Way Latch

The 4-Way latch has eight possible configurations, four with the curve of the lever facing outward and four with the curve of the lever facing inward. See diagram below.

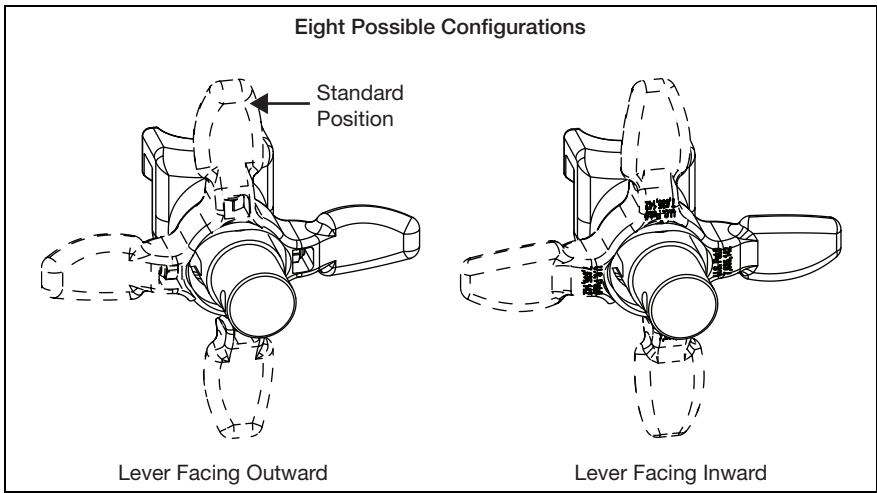

Rotating

1. To rotate the 4-Way Latch, remove the screw using a 3mm Allen wrench while the hanger is still on the chair (spring must be engaged to remove and reinsert screw and keeping the hanger on the chair keeps the spring engaged.) Ensure the nut does not fall out.
2. Rotate the 4-Way Latch to desired orientation and reinsert screw with 3mm Allen wrench. Ensure that the nut stays in position while tightening the screw. Do not overtighten screw or mechanism will bind.

NOTE: To reverse the 4-way latch, the same screw is removed, but the hanger has to be removed from the latch block. Once removed, slide the latch off, flip over and reinstall. Ensure spring is engaged, by pushing and holding the latch button in, and nut stays in position while reinstalling the screw.

NOTE: In-line position is not achievable with the Pro ELR Footrest option.

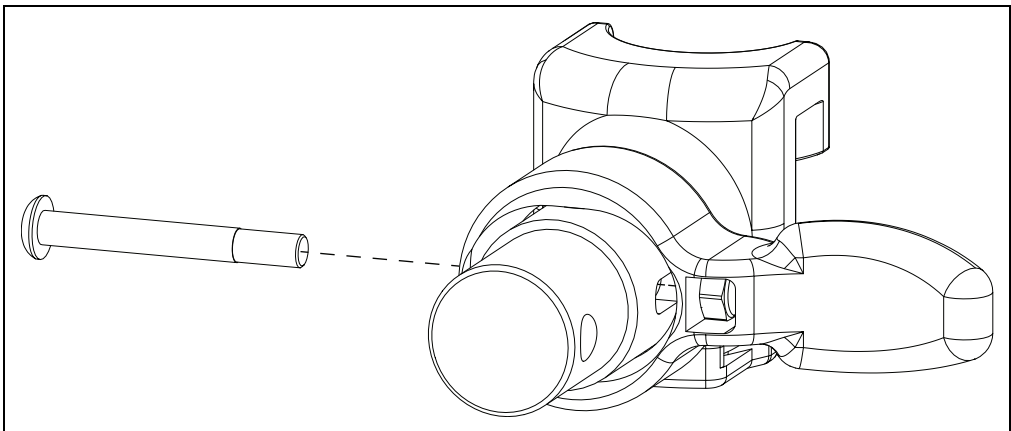

Backrest Angle Adjustment

1. Use a 4mm Allen wrench and a 10mm wrench to remove the button head screw and nut on the backrest.
2. Rotate backrest to desired angle. Each hole represents 5° of rotation. See diagram below for the angle for each hole.
3. Replace screw and nut in desired hole location.
4. Repeat for opposite side. Ensure both sides use the same configuration settings.

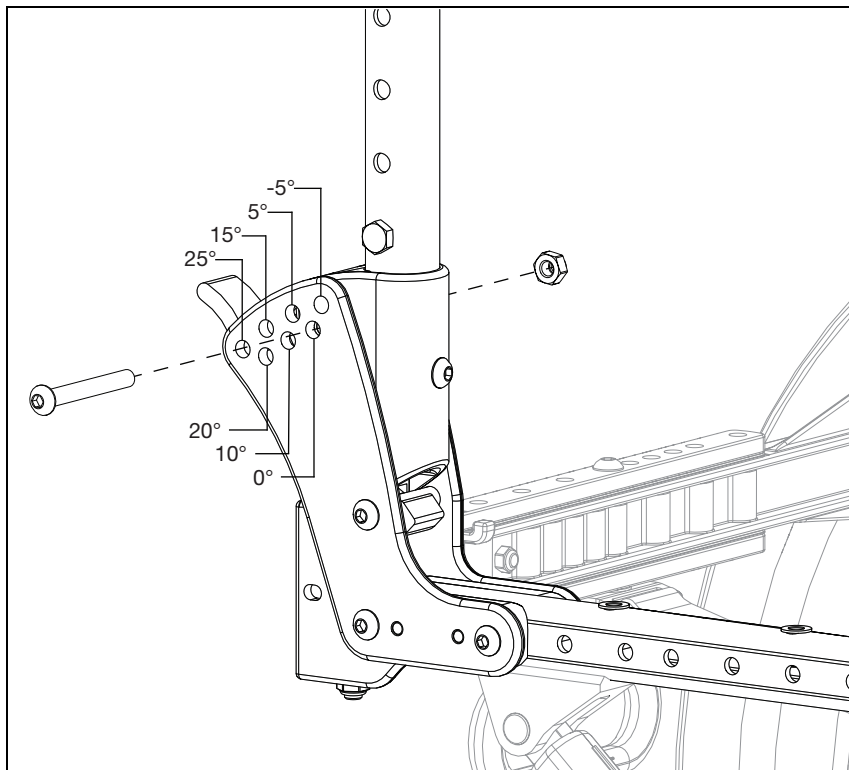

Seat Upholstery

1. Install seat rail and upholstery with screws using a Phillips screwdriver.

NOTE: Reference the chart below to determine the number of screws needed for the upholstery based on the seat depth.

NOTE: Ensure the right size seat rail is used (14", 16", 18" or 20").

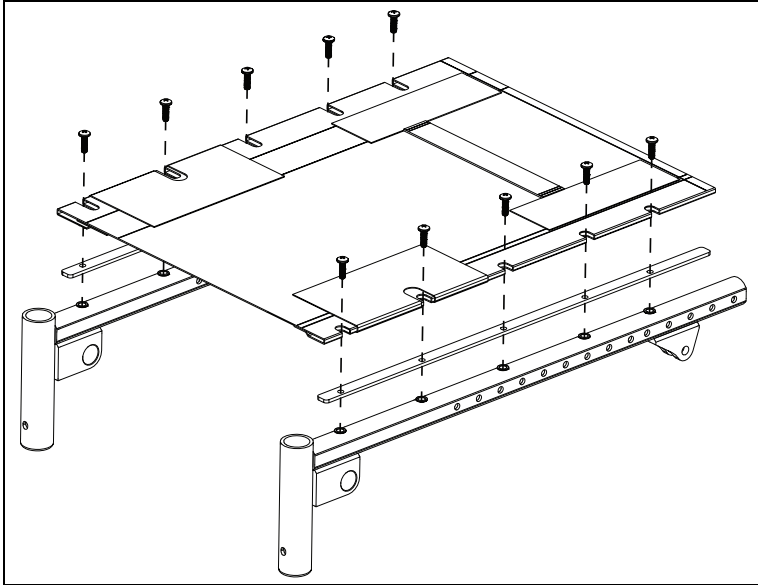

Screw Quantity per Chair		
Seat Depth	Seat Sling Depth	Screw Quantity
14	14	8
15	14	8
16	16	10
17	16	10
18	18	10
19	18	10
20	20	12

Adjusting Height Adjustable T-Arm Position

1. Remove two screws, two washers and two nuts from armrest receiver.
2. Move receiver to desired location on seat frame and reinstall screws, washers and nuts.

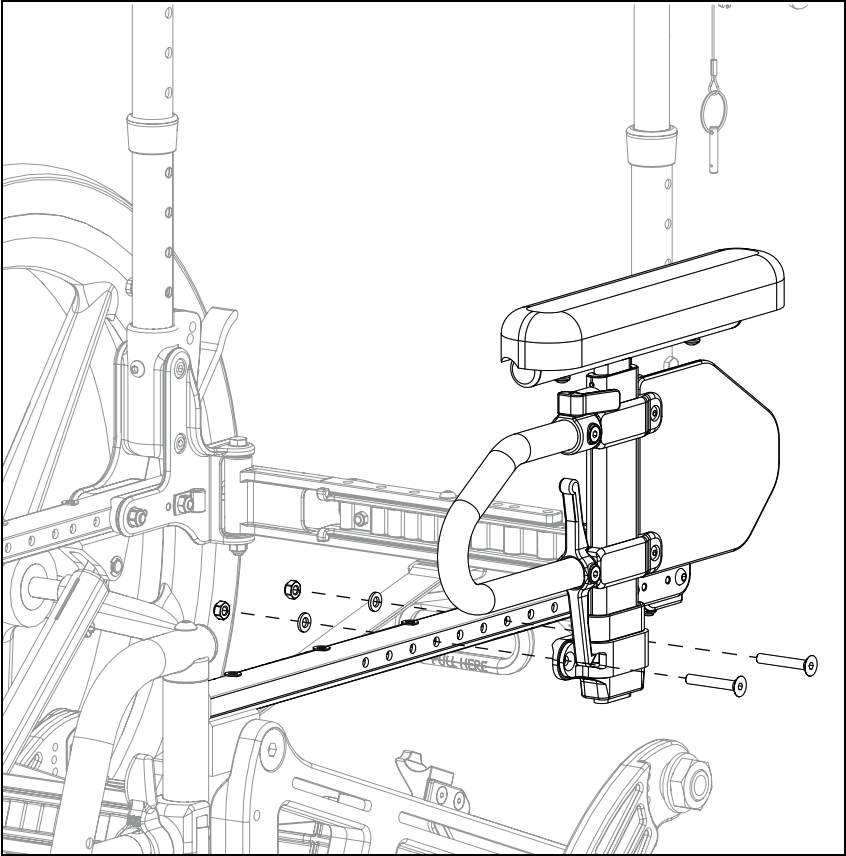

Angle Adjustable Locking Flip Up Extendable Armrest

1. Set the angle of the armrest. There are five holes that can be used to set the angle. Tighten the bolt once angle is set.

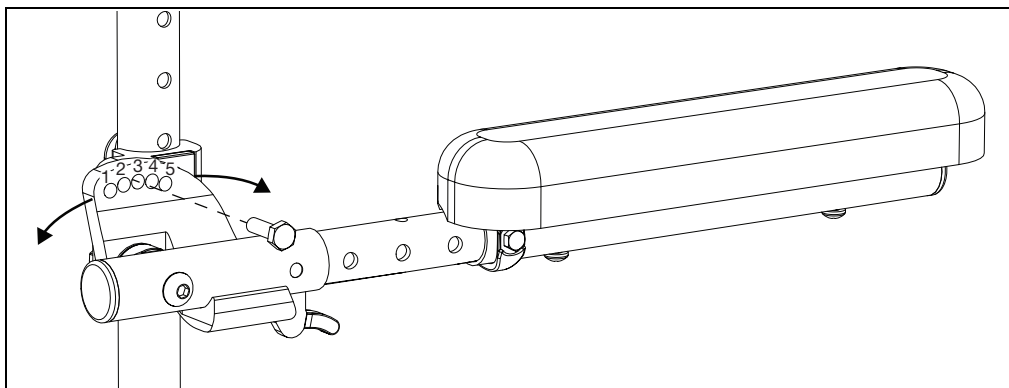

2. Set the length of the armrest. To adjust the length, remove the bolts and spacer on the tube and the screw closest to the back of the chair. Slide the armrest to desired length available by the predrilled holes and reinstall the screw and bolts.

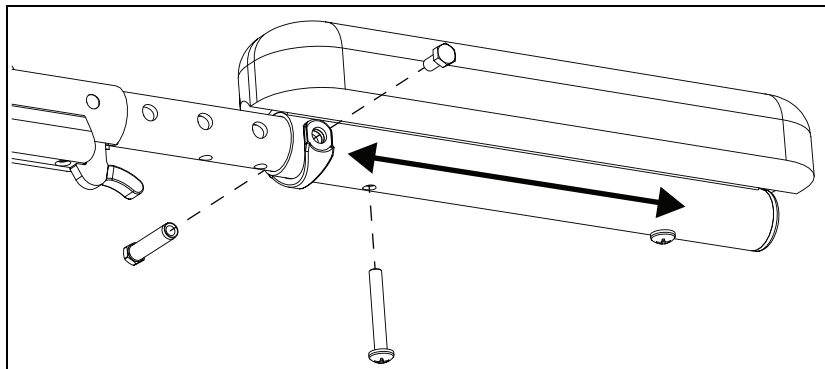

3. Set the height of the armrest. There are four holes on the armrest that allow for two different height settings for each set of holes on the back tube. Use the holes that provide the correct height setting for the user. The two bolts pass through the spacer, sleeves, back posts and into the armrest.

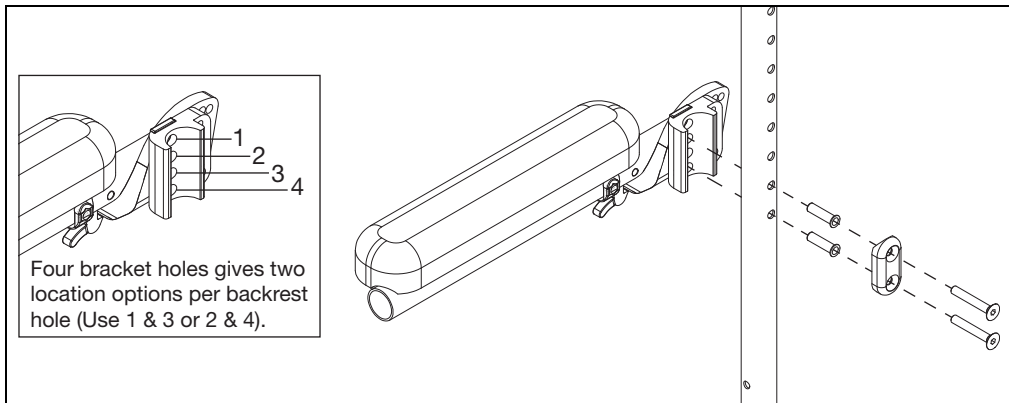

Anti-Tips

1. To adjust height, press in lower detent buttons.
2. Slide anti-tip up or down to desired height and allow detent buttons to click into new holes.
3. Repeat process on the opposite side. Ensure both sides are set in the same configuration.

See diagrams and charts below for additional anti-tip information.

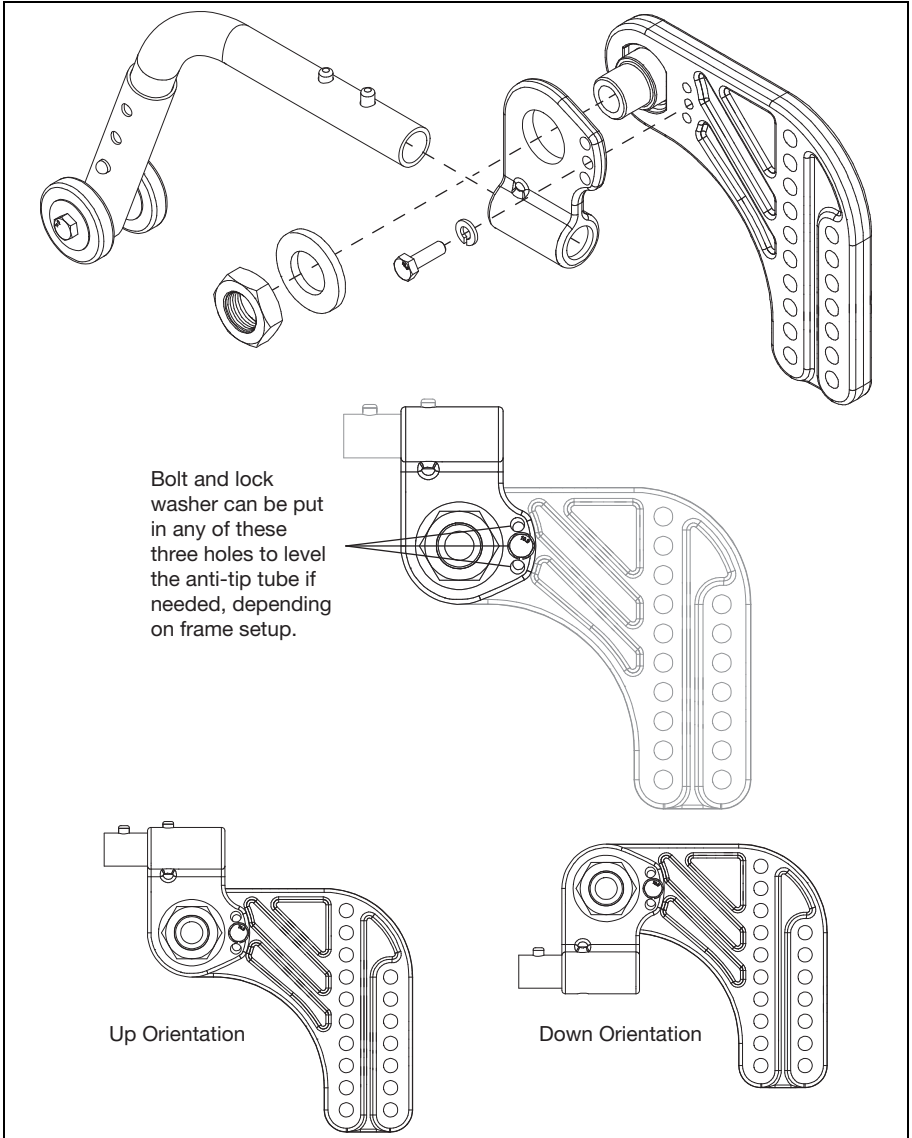

Rear Wheel Size	Receiver Orientation	Anti-Tip Tube Length	Anti-Tip Extension
12	Up	12"	Short
16	Up	16"	Long
20	Down	20"	Short
22	Down	22 - 24"	Long
24	Down	22 - 24"	Long

Multi-Angle Footrest

Installation

1. Determine which configuration the ball shaft (D) will need to be in - down (eversion) or up (inversion). See figure below for example. Install footplate (B) onto upper footrest clamp (C) with two screws (A) using a 4mm Allen wrench. Install ball shaft (D) into lower footrest clamp (E) and secure to the upper footrest clamp using three screws (G) and three lock washers (F) using a 5mm Allen wrench.

NOTE: Install the footplate to the upper footrest clamp using the set of holes needed for the desired configuration. The holes allow the footplate to be moved further inward or outward depending on preference.

NOTE: Torque the three screws (G) to 144 in/lbs.

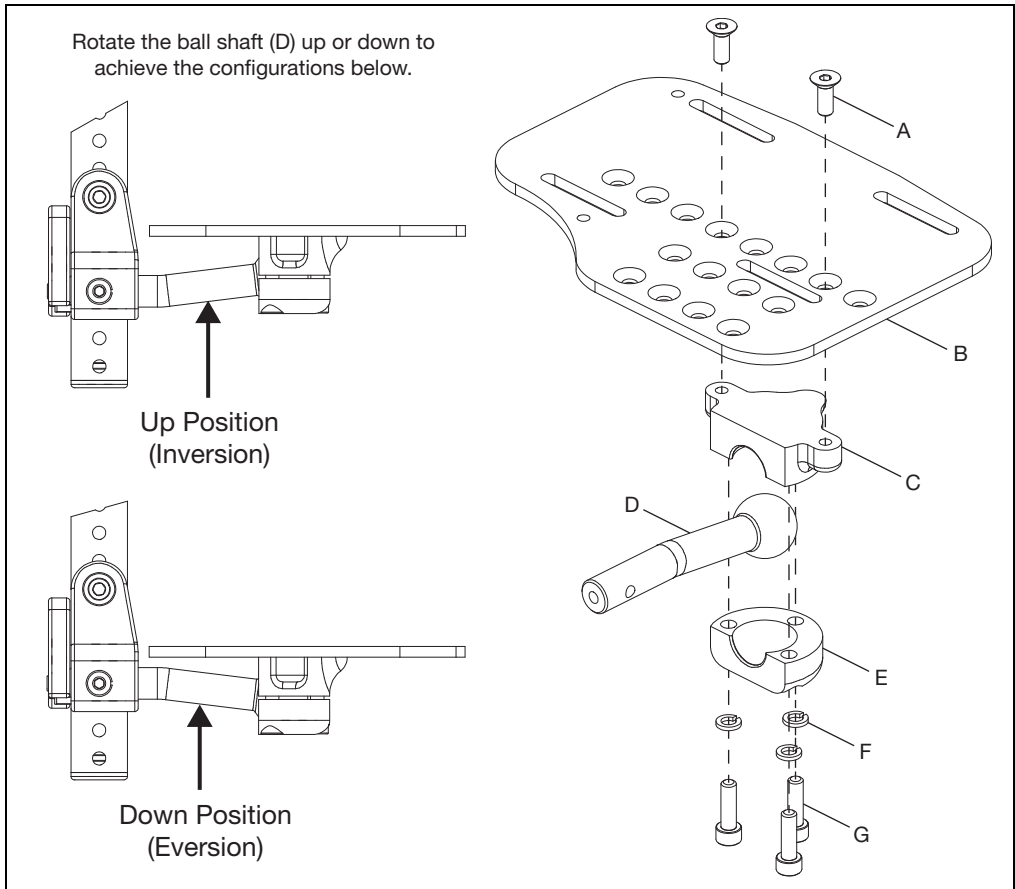

Multi-Angle Footrest

2. Install footrest mount (E) onto the end of the ball shaft and secure with screw (H) and lock washer (G) using a 4mm Allen wrench. Install the flip-up latch (D) onto the footrest mount and secure with latch spring (C), bushing (B) and screw (A) using a 4mm Allen wrench. Push spring pin (F) into the footrest mount to limit the movement of the flip-up latch.

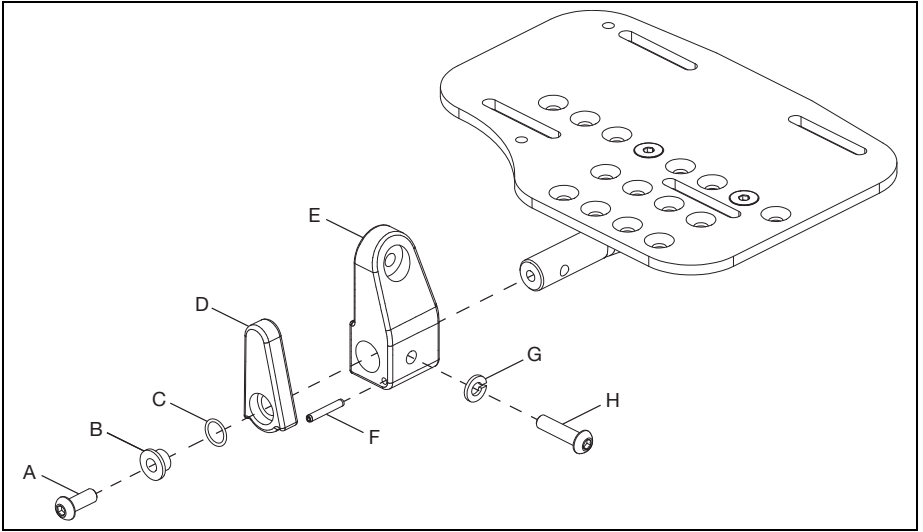

3. Install footplate assembly to hanger with screw (G), washer (Fig. 3:F), washer (E), saddle spacer (D), washer (C), washer (B) and nut (A) using a 5mm Allen wrench and a 10mm wrench.

NOTE: Install footplate assembly to hanger using the correct holes for the desired footrest height.

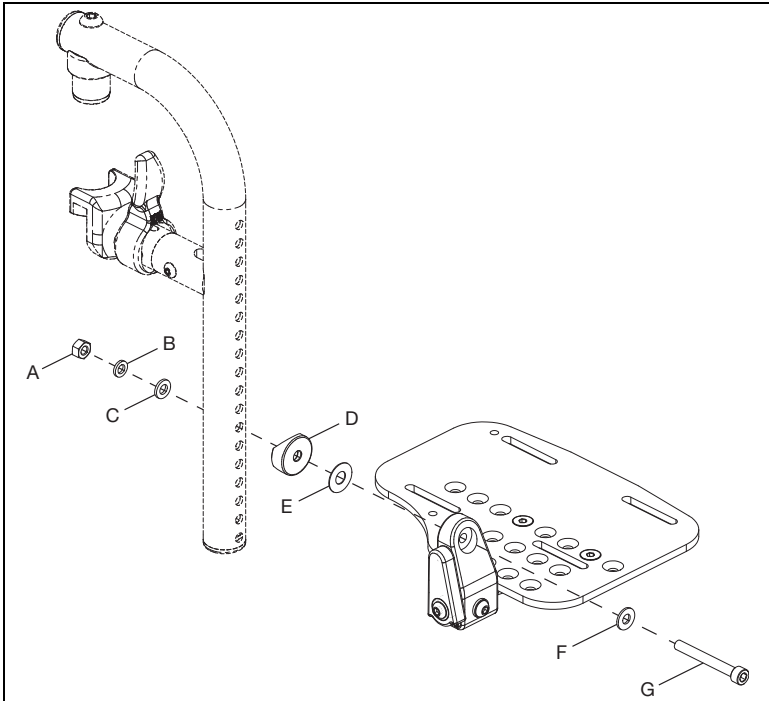



Ki Mobility
5201 Woodward Drive
Stevens Point, Wisconsin
54481
715-254-0991
www.kimobility.com



DCN0311.3