

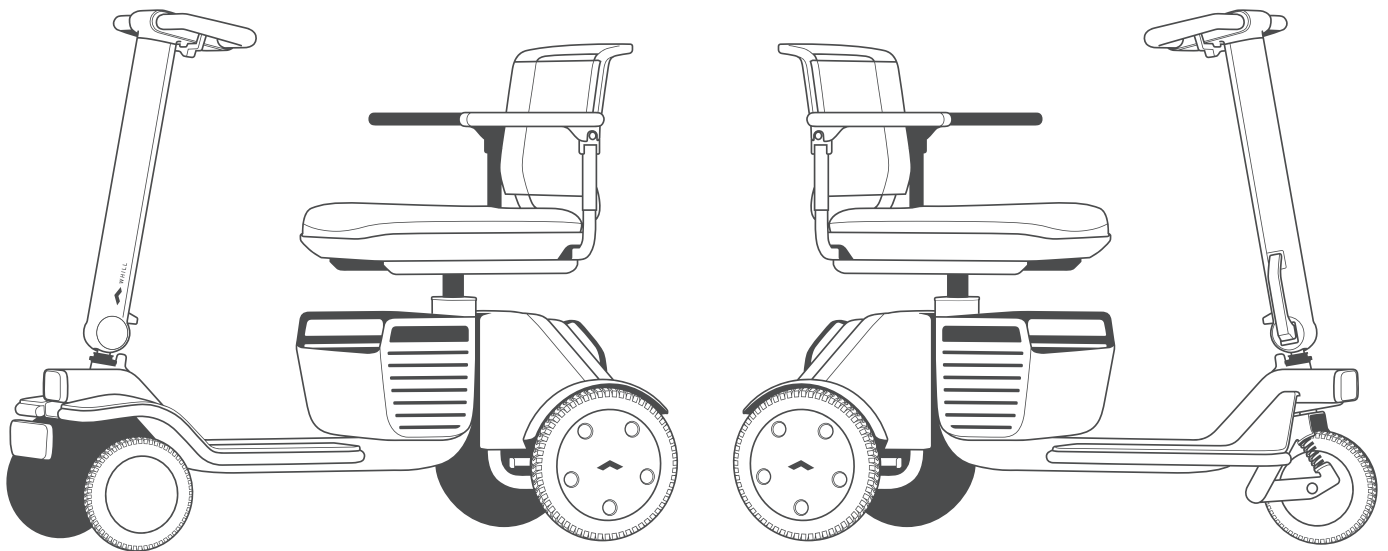

WHILL



User Manual

WHILL Model R Series

4-Wheel / 3-Wheel

en

Introduction

Thank you for your purchase of the WHILL Model R series (4-wheel type or 3-wheel type).

This product is intended to provide outdoor and indoor mobility to individuals who are comfortable with operating a powered scooter. The method of use of this product may differ according to country or region. Be sure to read this manual carefully before use, and use this device correctly and safely.







- This manual is intended for users of this product, and explains how to assemble and adjust the device, and how to use important functions such as the controller unit that controls speed and direction. It also explains basic inspections, troubleshooting, and maintenance procedures that can be performed by the user.
- This manual explains the various parts of this device by means of text, illustrations and standard terms.
- Store this manual in a location where it can be referred to whenever needed.
- This manual contains information that is protected by patent rights and copyrights. It may not be reproduced in part or in whole without explicit written permission from WHILL.
- The contents of this manual may be changed without notice.
For the latest information about this device, visit the WHILL Website (<https://whill.inc>).
- Every effort has been made to ensure the contents of this manual are correct. If you notice any inaccuracies or omissions in this manual, please contact your distributor or customer support.

Intended use/intended purpose:

The intended purpose of the WHILL Model R series powered scooter is to provide outdoor and indoor mobility to individuals who are comfortable with operating a powered scooter. Its usage may vary depending on the countries and areas.

Manual overview

The symbols used throughout this manual are described below. Be sure to observe the instructions indicated by each symbol.

Symbol	Meaning
 WARNING	Indicates critical instructions to prevent an imminently hazardous situation that may result in a fatal accident or serious injury.
 CAUTION	Indicates instructions to prevent a potentially hazardous situation that may result in minor or moderate injury, property damage or both.
	Indicates a required act.
	Indicates a prohibited act.
	Indicates precautions or reference information that must be read in order to prevent device malfunctions or failures, and to ensure comfortable device use.
	Indicates that the user should carefully read this manual before using this product to follow instructions and procedures.

Contents

Introduction.....	1
Manual overview	2
1. Safety precautions	6
1.1. Upon using this device	6
1.2. When getting in and driving this device.....	8
1.3. Precautions when assembling or adjusting.....	11
1.4. EMI (Electromagnetic Interference)	12
1.4.1. General Q&A on EMI and RFI.....	12
1.4.2. Important information regarding Electro Magnetic Compatibility (EMC)	13
1.4.3. FCC and ISED information	16
1.5. Labels on this device	18
1.6. Reporting of serious incident	18
2. About this device	20
2.1. Checking condition of the package.....	20
2.2. Packaged items	20
2.3. Names and functions of parts	21
2.4. Accessories	24
3. Assembly, adjustment and disassembly	26
3.1. Names of parts	27
3.2. Required tools.....	29
3.3. Assembly procedures	29
3.3.1. Assembling the drive base and main body.....	30
3.3.2. Unfolding the tiller unit	32
3.3.3. Installing the tiller cover	33
3.3.4. Installing the seat post	34
3.3.5. Installing the basket	35
3.3.6. Installing the seat base	36
3.3.7. Installing the seat cushion onto the seat	36
3.3.8. Installing the armrests	37
3.3.9. Installing the battery	37
3.4. Adjustment procedures	39
3.4.1. Adjusting the tiller unit angle.....	40
3.4.2. Adjusting the seat height.....	41

3.4.3.	Adjusting the seat forward/backward position	43
3.4.4.	Adjusting the space between armrests.....	45
3.4.5.	Adjusting the height of the armrest	46
3.4.6.	Adjusting the light angle of the front light	47
3.5.	Disassembly procedures	47
3.5.1.	Removing the battery.....	48
3.5.2.	Removing the seat assembly.....	49
3.5.3.	Removing the basket	49
3.5.4.	Folding the tiller unit	50
3.5.5.	Removing the drive base	51
4.	Charging the battery	52
4.1.	Battery and charger	55
4.2.	Charging procedures	55
4.2.1.	Charging with the battery installed on this device.....	56
4.2.2.	Charging with the battery removed	58
4.2.3.	Charger indicator displays.....	60
5.	Operating procedures	62
5.1.	Inspection before getting in this device.....	63
5.2.	Getting on this device.....	64
5.2.1.	Rotating the seat and getting in this device	66
5.3.	Turning the power supply ON	67
5.3.1.	Checking the battery charge level.....	68
5.3.2.	Setting the maximum speed.....	69
5.3.3.	Using the horn button.....	69
5.3.4.	Using the front light button	69
5.4.	Driving	70
5.4.1.	Moving forwards and backwards.....	74
5.4.2.	Turning corners	74
5.4.3.	Turning.....	74
5.4.4.	Stopping	75
5.4.5.	Adjusting the speed	75
5.4.6.	Driving under different road conditions	75
5.5.	Turning the power supply OFF.....	76
5.6.	Releasing the brakes	77
5.6.1.	Brake release procedure	77
5.7.	Carrying items	78

6. Storage and transport methods	80
6.1. Storage.....	80
6.2. Transporting this device	81
6.2.1. How to hold each part.....	82
6.2.2. Loading/unloading this device onto/from a vehicle	84
7. About the smartphone app	86
8. Maintenance and inspection.....	88
8.1. Cleaning, disinfection and user maintenance.....	88
8.2. Inspection.....	89
8.3. Repair performed by the manufacturer or distributor.....	89
8.4. Disposal	89
8.5. Product warranty	89
8.6. Reuse information	90
8.7. How to check the manufacture date of the device	90
9. Troubleshooting	92
10. Specifications.....	94
Symbols.....	100
Index.....	101
Contact information	103

1. Safety precautions

This device has been designed and manufactured with complete attention given to safety. However, there is the risk of injury, unexpected accident or property damage if precautions given in this manual are ignored or this device is used incorrectly.

The descriptions related to safety utilize the terms “WARNING” and “CAUTION” to indicate the degree of injury or damage and the level of danger. “WARNING” indicates critical instructions to prevent an imminently hazardous situation that may result in a fatal accident or serious injury. “CAUTION” indicates instructions to prevent a potentially hazardous situation that may result in minor or moderate injury, property damage or both.

This device is a powered scooter. Correctly understand the contents of this manual before using this device. Persons who find it difficult to use a powered scooter should not use this device.

- **This device is designed for use on paved roads or indoor use.**
- **This device is designed for use in pedestrian areas. When driving, please use pedestrian paths, observing the traffic law.**
- **If this device is being operated by an assistant to the occupant, the assistant must thoroughly read this manual and fully understand the precautions for use before operating it.**

1.1. Upon using this device

WARNING



- **If this device shows any abnormal signs, immediately discontinue use, and contact your distributor or customer support.**

Continuing to use this device when it is malfunctioning can potentially cause an injury or unexpected accident.

- **Carefully read the explanations in this manual regarding the battery and charger, and follow the instructions.**

There is a risk of fire or battery explosion when disassembling the battery or charger. Do not allow flames near the battery or charger, avoid getting the battery and charger wet or subjecting them to impact (dropping, penetration with nails, or standing on them), etc.



- **When this device is not being used, turn the device power supply OFF.**

There is a risk of accidental contact with the controller unit that could cause unexpected movement of this device.

- **Unsafe in the Magnetic Resonance (MR) Environment.**

This device is MR Unsafe. The device presents a projectile hazard.



- **The maximum load-bearing capacity for this device is 147 kg (325 lbs.) including both the occupant and any luggage. Use this device without subjecting it to a load higher than this capacity.**

Otherwise, there is a risk of damage to parts or unexpected accident.



- **Do not lift up this device when there is a person on it.**

There is a risk of injury to the occupant or damage to parts as a result of tipping over or falling.

⚠ WARNING



- **This device is not play apparatus. Use this device only as a powered scooter. Do not use it for other applications.**
Otherwise, there is a risk of accident.
- **This device should not be used by people whose feet do not reach the footrest when on this device even if the seat height is adjusted.**
This device may tip over or fall, and there is a risk of unexpected accident.
- **Do not apply an excessive load to the controller unit, such as leaning or sitting on it. Do not operate the throttle control lever or buttons with excessive force or operate them with a sharp object.**
These parts might become damaged and render them inoperable.
- **Do not hang walking sticks, umbrellas, bags, baskets, or other objects on the tiller handle, throttle control lever and armrests.**
Otherwise, there is a risk of damage to parts or unexpected accident.
- **Do not attach stickers or paint on top of the controller unit display, buttons, or the labels attached to this device, battery, charger, and other parts.**
There is a risk that these indications may no longer be visible, resulting in incorrect operation and unexpected accident.
- **Do not use this device as a seat in an automobile or other vehicle.**
Otherwise, there is a risk of damage to parts or unexpected accident.
The symbol on the right indicates that this device is not intended to be used as a seat in a motor vehicle. 
- **This device is for one occupant only. It is not to be used by two or more people (including children or pets).**
Otherwise, there is a risk of damage to parts or unexpected accident.
- **Do not allow others to use this device without adequate instructions or explanation.**
Otherwise, there is a risk of damage to parts or unexpected accident.
- **Do not drive this device while holding onto a dog leash or leash for other pets.**
This device may tip over or fall, and there is a risk of unexpected accident.

⚠ CAUTION



- **If this device is not used for a long period, fully charge the battery before storing. Charge the battery at least once a month.**
There is a risk that the battery may get excessively depleted and cannot be charged.
- **Pay attention to the surface temperature of this device when it is in use.**
When the surface temperature of this device becomes extremely hot as a result of exposure to the direct sunlight or an external heat source, there is the risk of burns. Do not leave this device in the direct sunlight or near external heat sources.

1.2. When getting in and driving this device

1

WARNING



- **Turn the device power supply OFF when getting in and out of the device.**
There is a risk of unexpected movement of this device caused by accidental contact with the controller unit.
- **When driving, fully check the surroundings and road conditions. Drive carefully at low speed particularly when driving in locations crowded with people, close to walls or other locations where there are obstacles nearby, and in narrow places or on uneven surfaces or slopes. Do not drive off or stop suddenly.**
When driving on wet inclines, in particular, there is a risk that this device may lose stability, and cause an unexpected accident.
- **When approaching curbs, steps, slopes, and similar obstacles, approach at a right angle and drive over them carefully at low speed. On 4-wheel types, make sure you are not driving with only one front wheel on curbs, steps, slopes, and similar obstacles. On 3-wheel types, make sure you are not driving with the anti-tip rollers (front) on curbs, steps, slopes, and similar obstacles.**
There is a risk of tipping over or damage to parts.
- **When stopping on a downhill slope, return the throttle control lever promptly to its original position, and make sure that this device stops with an ample amount of extra space around it.**
The stopping distance is longer when on a downhill slope. There is a risk that you may be unable to stop at the expected position, causing an unexpected accident.
- **Release the brakes only when necessary. Before releasing the brakes, be sure to move to a flat and safe surface, and then turn the device power supply OFF. After moving this device manually, pull the brake release levers upwards to apply the brakes.**
There is a risk of unexpected accident because this device will move freely when the brakes are released.



- **Do not drive the device in the following areas or under the following conditions.**
This device may tip over, and there is a risk of unexpected accident.
 - Escalators or stairs
 - Steps of 5 cm (2 in.) or more in height
 - Slopes with a gradient of 10° or more
 - Soft surfaces such as sand or mud
 - Puddles
 - Snowy or frozen paths
 - Diagonal driving on slopes that exceed 10° left and right
 - Gaps of 10 cm (3.9 in.) or more in width
 - Sudden turning or driving in a zigzag
 - Driving in reverse or medium- to high-speed driving on downhill slopes
 - Bad weather such as rain, fog or strong wind
- **When you do not feel well, are under the influence of alcohol or are taking medication, do not drive this device.**
This may dull your judgment, and cause the risk of serious accident.
- **While riding this device, do not crouch down, lean outside, or shake your body.**
This device may tip over or fall, and there is a risk of unexpected accident.

WARNING



- **Do not drive while holding something in your hand or with something placed on your lap.**
There is a risk of incorrect operation or tipping over.
- **While driving, do not operate a mobile phone, smartphone or other devices. Before operating these devices, stop the scooter at a safe place, and turn the scooter power supply OFF. Also, do not drive while wearing earphones or headphones that make it difficult to hear surrounding sounds.**
Otherwise, there is a risk of accident.

1

CAUTION



- **Where adjustments can be made, first adjust this device to an easy-to-use position and angle.**
Otherwise, there is a risk of incorrect operation. Also, this device may tip over or fall, and there is a risk of unexpected accident.
- **On downhill slopes, slow down sufficiently and drive carefully.**
This device may tip over or fall, and there is a risk of unexpected accident.
- **When driving this device, sit back in the seat so that your back is resting against the back support.**
This device may tip over or fall, and there is a risk of unexpected accident.



- **Even if accompanied by an assistant, do not stop for a long time on a downhill slope while still seated.**
Otherwise, there is a risk of accident.



- This device is intended for use in pedestrian areas. When driving, please use pedestrian paths, observing the traffic law.
- Do not drive hands-free or with one hand and do not take your eyes off the route ahead. Otherwise, there is a risk of accident.
- At night, turn the front light ON and drive while paying special attention.

■ How to avoid an emergency situation

When this device no longer moves in an emergency or because of a malfunction or the like, it can be moved manually by pushing down the brake release levers located below the seat to release the brakes. When moving this device manually, move it to as flat a location as possible.

1. Turn the power OFF.
2. Push the brake release levers downwards to release the brakes.
3. Move this device to a safe place manually.

■ Precautions during driving (across level crossings or on streetcar tracks)

⚠ WARNING



- In the event that this device gets stuck in the middle of a level crossing or on railway tracks, ask the assistant or people nearby for help to immediately evacuate from the level crossing or railway tracks. If this device is left in the middle of a level crossing or on railway tracks, immediately press the level crossing's emergency button.
There is a risk of serious accidents.
- Do not lift up this device when there is a person on it.
There is a risk of injury to the occupant or damage to parts as a result of tipping over or falling.

⚠ CAUTION



- Avoid crossing level crossings as there is the risk of getting stuck in the middle of the crossing. When it is absolutely necessary to cross a level crossing, pay attention to the following. Also pay attention to the following when crossing streetcar tracks.
Otherwise, there is a risk of accident.
 - Before crossing level crossings and railway tracks, check that the battery charge level is sufficient.
 - Be accompanied by an assistant.
 - In the case of wide level crossings and railway tracks that will take time to cross, make a detour.
 - When the level crossing alarm starts to sound or the level crossing barrier starts to drop, never move inside the level crossing.
 - Cross level crossings at right angles to the railway tracks to prevent this device from getting caught in the gaps of the tracks.
 - Do not rotate on level crossings and railway tracks.

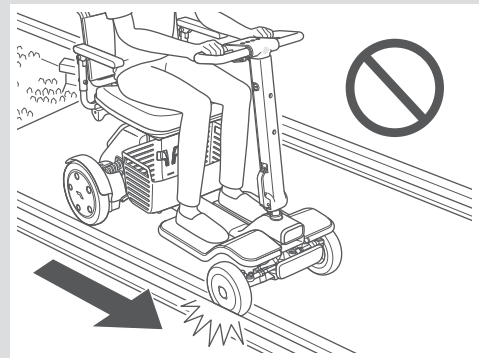
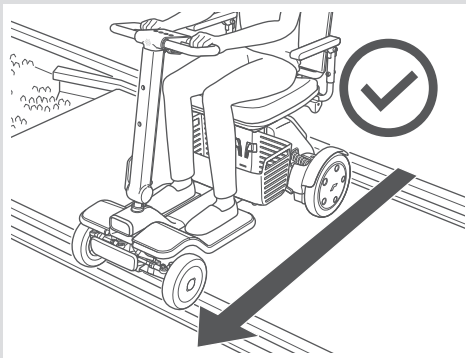

This device cannot be driven over steps of 5 cm (2 in.) or more in height or gaps of 10 cm (3.9 in.) or more in width. In these cases, either lift up this device or use a slope board or the like. Refer to “6.2. Transporting this device” on page 81.

1.3. Precautions when assembling or adjusting

⚠ WARNING



- Assemble this device in the order described in this user manual. Do not perform any adjustment, repair, or modification that is not listed in this manual.
There is a risk of injury and product safety risk due to damage to this device or its parts. Performing repair or modification which is not listed in this manual will invalidate the warranty.
- Perform assembly on a flat and level surface.
Otherwise, there is a risk of accident.
- Before performing adjustments, turn the power supply OFF, and apply the brakes on a flat and level surface.
Otherwise, there is a risk of accident.



- Do not touch the battery connector socket or battery connector port directly, allow them to become wet, or bring foreign objects close to them. When inserting the battery, ensure that there are no foreign objects attached.
Otherwise, there is a risk of injury or electric shock and of damage to this device or its parts.

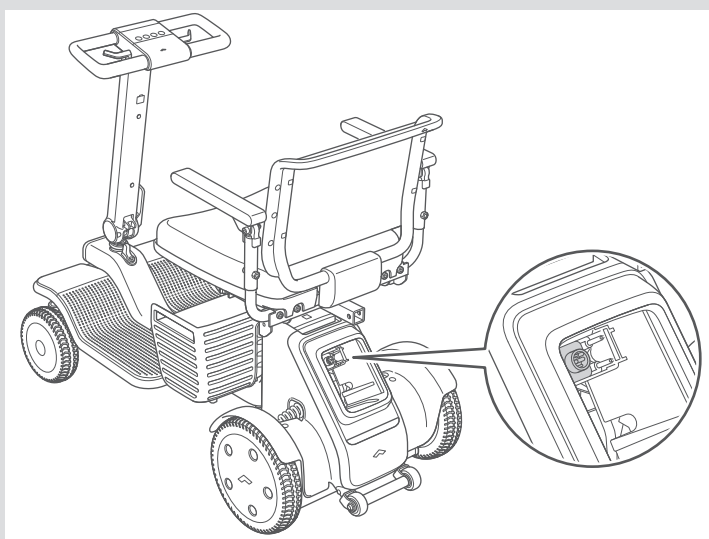

Battery connector port

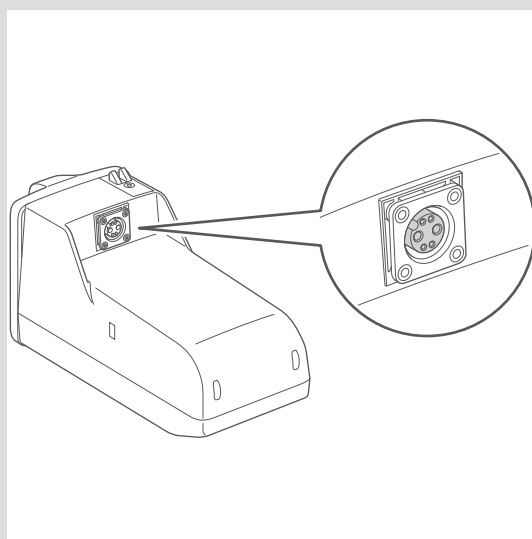

Battery connector socket

- Do not touch the drive base connector socket or main body connector port directly, allow them to become wet, or bring foreign objects close to them. When assembling, ensure that there are no foreign objects attached.
Otherwise, there is a risk of injury or electric shock and of damage to this device or its parts.

1.4. EMI (Electromagnetic Interference)

There is a risk of unintended movement of this device as a result of radio waves. Avoid driving in an area where strong electromagnetic waves are generated such as areas around high-tension wires, high-voltage power lines, television towers, etc. Radio waves may interfere with the control functions of this device.

This device may also emit its own electromagnetic fields and may disturb the operation of other nearby devices. To reduce the chance of unintended device movement, which could result in serious injury, pay careful attention to the following instructions.

- Do not operate hand-held transceivers, such as citizens band (CB) radios, while the device power supply is turned ON.
- Look for nearby transmitters, such as radio or TV stations and towers, and try to avoid coming close to them.

If this device moves or stops when the device controller is not operated, or if this device operates in a way different than intended, take the following actions.

- Turn the device power supply OFF as soon as it is safe.
- If this device moved in a way different from intended, note down how it was operated immediately beforehand.
- Note down the device operation that could not be activated using the controller.
- Note down the electronic devices in the immediate area that may be sources of radio waves near this device.

Based on these notes, consider the possible cause of radio frequency interference and remove it. If the problem is still not resolved, contact your distributor or customer support. At this time, keep your earlier notes at hand.



If radio frequency interference is suspected, turn the power OFF and disconnect the battery.

1.4.1. General Q&A on EMI and RFI

The following are general questions and answers regarding steps to avoid nearly all of the effects of EMI and RFI with this device. Please use them as reference.

● Where do radio waves come from?

Radio waves are emitted by unidirectional or bidirectional radio devices. Such devices include transceivers, mobile phones, wireless computer links, microwave generators, and radio call transmitters. Radio waves are a form of electromagnetic energy, and the strength of the energy increases at closer distances to the transmitting antenna. This electromagnetic field might cause problems for users of electric equipment.

● What kind of movements should I expect if this device is affected by EMI or RFI?

EMI and RFI undergo extremely large dynamic changes and might affect a device depending on conditions such as the following.

- Radio wave frequency and strength
- Structure of the power supply equipment

- Inclination of this device (whether the ground is flat or slanted)
- Whether this device is turned ON and whether it is moving

If this device is affected, there is a possibility of abnormal movement. It may begin moving uncontrollably or stop suddenly. Strong EMI or RFI can cause the control system to malfunction.

1.4.2. Important information regarding Electro Magnetic Compatibility (EMC)

Cable information is provided below for EMC reference.

Cable	Max. cable length, Shielded/unshielded		Number	Cable classification
AC Power Line	1.5 m (4.9 ft)	Unshielded	1 Set	AC Power
DC Power Line	1.2 m (3.9 ft)	Unshielded	1 Set	DC Power

This electrical medical device needs special precautions regarding EMC and should be operated according to the EMC information provided in the user manual; The device conforms to the IEC 60601-1-2 standard for both immunity and emissions. Special precautions need to be observed as follows:

- The device is intended for use in the home healthcare environment.
- If the essential performance of the device is lost or degraded due to electromagnetic disturbances, unintended acceleration, stop, or control may occur.
- **WARNING:** Use of this device adjacent to or stacked with other device should be avoided because it could result in improper operation. If such use is necessary, this device and the other device should be observed to verify that they are operating normally.
- The use of accessories, transducers and cables other than those specified or provided by the manufacturer of this device could result in increased electromagnetic emissions or decreased electromagnetic immunity of this device and result in improper operation.
- **WARNING:** Portable RF communications device (including peripherals such as antenna cables and external antennas) should be used no closer than 30 cm (12 inches) to any part of the Model R series, including cables specified by the manufacturer. Otherwise, the performance of this device could degrade.
- **WARNING:** If the use location is near (e.g. less than 1.5 km (0.9 miles) from) to AM, FM or TV broadcast antennas, it should be observed to verify that it is operating normally before using this device, to assure that the device remains safe with regard to electromagnetic disturbances throughout the expected service life.
- When the AC input voltage is interrupted, the device will stop battery charging and if the power supply restored, it could be recovered automatically. This degradation could be accepted because it will not lead to unacceptable risks and it will not result in the loss of basic safety or essential performance.

During all immunity tests, a digital tachometer was used to monitor the rotating speed of wheel and a clamp meter was used to monitor the output current of battery charger to verify the performance of EUT.

EMI Compliance Table (Table 1)

Table 1 - Emission

Phenomenon	Compliance	Electromagnetic environment
RF emissions	CISPR 11 Group 1, Class B	Home healthcare environment
Harmonic distortion	IEC 61000-3-2 Class A	Home healthcare environment
Voltage fluctuations and flicker	IEC 61000-3-3 Compliance	Home healthcare environment

MS Compliance Table (Table 2-5)

Table 2 - Enclosure Port

Phenomenon	Basic EMC standard	Immunity test levels Home healthcare environment
Electrostatic Discharge	IEC 61000-4-2	±8 kV contact ±2 kV, ±4 kV, ±8 kV, ±15 kV air
Radiated RF EM field	IEC 61000-4-3	20 V/m 26 MHz-2.5 GHz 80% AM at 1 kHz 10 V/m 80 MHz-2.7 GHz 80% AM at 1 kHz
Proximity fields from RF wireless communications equipment	IEC 61000-4-3	Refer to table 3
Rated power frequency magnetic fields	IEC 61000-4-8	30 A/m 50 Hz or 60 Hz
Proximity magnetic fields	IEC 61000-4-39	30 kHz, CW, 8 A/m 134.2 kHz, pulse modulation 2.1 kHz, 65 A/m 13.56 MHz, pulse modulation 50 kHz, 7.5 A/m

Table 3 - Proximity fields from RF wireless communications equipment

Test frequency (MHz)	Band (MHz)	Immunity test levels Home healthcare environment
385	380-390	Pulse modulation 18 Hz, 27 V/m
450	430-470	FM, ± 5 kHz deviation, 1 kHz sine, 28 V/m
710	704-787	Pulse modulation 217 Hz, 9 V/m
745		
780		
810	800-960	Pulse modulation 18 Hz, 28 V/m
870		
930		
1720	1700-1990	Pulse modulation 217 Hz, 28 V/m
1845		
1970		
2450	2400-2570	Pulse modulation 217 Hz, 28 V/m
5240	5100-5800	Pulse modulation 217 Hz, 9 V/m
5500		
5785		

Table 4 - Input a.c. power Port

Phenomenon	Basic EMC standard	Immunity test levels Home healthcare environment
Electrical fast transients/ burst	IEC 61000-4-4	± 1 kV ± 2 kV 100 kHz repetition frequency
Surges Line-to-line	IEC 61000-4-5	± 0.5 kV, ± 1 kV
Conducted disturbances induced by RF fields	IEC 61000-4-6	3 V, 0.15 MHz-80 MHz 6 V in ISM bands and amateur radio bands between 0.15 MHz and 80 MHz 80% AM at 1 kHz
Voltage dips	IEC 61000-4-11	0% U_T ; 0.5 cycle At 0°, 45°, 90°, 135°, 180°, 225°, 270° and 315°
		0% U_T ; 1 cycle and 70% U_T ; 25/30 cycles Single phase: at 0°
Voltage interruptions	IEC 61000-4-11	0% U_T ; 250/300 cycles

Table 5 - Signal input/output parts Port

Phenomenon	Basic EMC standard	Immunity test levels Home healthcare environment
Conducted disturbances induced by RF fields	IEC 61000-4-6	3 V, 0.15 MHz-80 MHz 6 V in ISM bands and amateur radio bands between 0.15 MHz and 80 MHz 80% AM at 1 kHz

1.4.3. FCC and ISED information

The control pad on the WHILL Model R series contains the wireless communication modules that are regulated by the FCC (Federal Communications Commission) and the ISED (Innovation, Science and Economic Development Canada).

The control pad is labelled with an FCC ID and an ISED certification number. The label is accessible without the use of a tool by removing the control pad as shown in Section "Switching the position of the control pad".

● FCC Information

This device complies with part 15 subpart B and C of the FCC rules. Operation is subject to the following two conditions.

- (1) This device may not cause harmful interference.
- (2) This device must accept any interference received, including interference that may cause undesired operation.

This equipment has been tested and found to comply with the limits for a Class B digital device, pursuant to part 15 of the FCC Rules. These limits are designed to provide reasonable protection against harmful interference in a residential installation. This equipment generates, uses, and can radiate radio frequency energy and, if not installed and used in accordance with the instructions, may cause harmful interference to radio communications. However, there is no guarantee that interference will not occur in a particular installation. If this equipment does cause harmful interference to radio or television reception, which can be determined by turning the equipment off and on, the user is encouraged to try to correct the interference by one or more of the following measures:

- Reorient or relocate the receiving antenna.
- Increase the separation between the equipment and receiver.
- Connect the equipment into an outlet on a circuit different from that to which the receiver is connected.
- Consult the dealer or an experienced radio/TV technician for help.

CAUTION: Changes or modifications not expressly approved by the manufacturer could void the user's authority to operate this equipment.

This device meets the government's requirements for exposure to radio waves. This device is designed and manufactured not to exceed the emission limits for exposure to radio frequency (RF) energy set by the Federal Communications Commission of the U.S. Government.

RF Exposure Warning

This equipment must be installed and operated in accordance with provided instructions and the antenna(s) used for this transmitter must be installed to provide a separation distance of at least 20 cm (7.9 in.) from all persons and must not be co-located or operating in conjunction with any other antenna or transmitter. End-users and installers must be provided with antenna installation instructions and transmitter operating conditions for satisfying RF exposure compliance.

● ISED Information

This Class B device complies with Canadian ICES-3 (B). This device contains licence-exempt transmitters/receivers that comply with Innovation, Science and Economic Development Canada's license-exempt RSS(s). Operation is subject to the following two conditions: (1) This device may not cause interference. (2) This device must accept any interference, including interference that may cause undesired operation of the device.

Cet appareil numérique de la classe B est conforme à la norme NMB-3 (B) du Canada. L'émetteur/récepteur exempt de licence contenu dans le présent appareil est conforme aux CNR d'Innovation, Sciences et Développement économique Canada applicables aux appareils radio exempts de licence. L'exploitation est autorisée aux deux conditions suivantes : (1) L'appareil ne doit pas produire de brouillage; (2) L'appareil doit accepter tout brouillage radioélectrique subi, même si le brouillage est susceptible d'en compromettre le fonctionnement.

Radio Frequency (RF) Exposure Information

The radiated output power of the Wireless Device is below the ISED radio frequency exposure limits. The Wireless Device should be used in such a manner such that the potential for human contact during normal operation is minimized.

This device has been evaluated for and shown compliant with the ISED Canada RF Exposure limits under mobile exposure conditions (antennas are greater than 20 cm (7.9 in.) from a person's body).

Informations concernant l'exposition aux fréquences radio (RF)

La puissance de sortie émise par l'appareil sans fil est inférieure à la limite d'exposition aux fréquences radio d'ISDE Canada. Utilisez l'appareil sans fil de façon à minimiser les contacts humains lors du fonctionnement normal.

Ce dispositif a été évalué et démontré conforme aux limites d'exposition aux RF d'ISDE Canada dans des conditions d'exposition à des appareils mobiles (antennes sont supérieures à 20 cm à partir du corps d'une personne).

1.5. Labels on this device

1

Warning labels are attached on areas that require attention to safety during operation of this device. Also, labels indicate information that is important in the use of this device such as device information.

There may be additional labels not described in this manual depending on the sales area or model.

CAUTION



- Do not remove the labels.
The labels contain important information.

1.6. Reporting of serious incident

Any serious incident that has occurred in relation to the device shall be reported immediately to WHILL and the competent authority in which the user is located. For details on how to contact your distributor or customer support, refer to “Contact information” on page 103.

2. About this device

This device is designed for use in pedestrian areas. When driving, use pedestrian paths, observing rules and expected manners. Use this device for intended purpose. Do not use it as play apparatus or for other applications.

2.1. Checking condition of the package

Before unpacking this device, make sure that the packaging box is free of damage or signs of unpacking during transportation. In the event that there is damage or signs of unpacking during transportation, do not use this device, and consult your distributor or customer support.

2.2. Packaged items

The following items are packaged with this device. Before using this device, be sure to check that there are no missing items or damaged parts on this device. In the event that any items are missing or damaged, contact the distributor or customer support.

- Drive base
- Main body
- Seat post
 - Bolt (M10 60 mm) x 1
- Tiller cover (front)
- Tiller cover (rear)
 - Bolt (M4 12 mm) x 4
- Basket
- Seat base
- Seat cushion
- Armrests
 - Bolt (M8 30 mm) x 4
- Battery
- Charger
- Mechanical key x 2
- User manual (this manual)
- Warranty



Be careful not to scratch packaged items when opening packages.

2.3. Names and functions of parts

■ Device

4-Wheel type

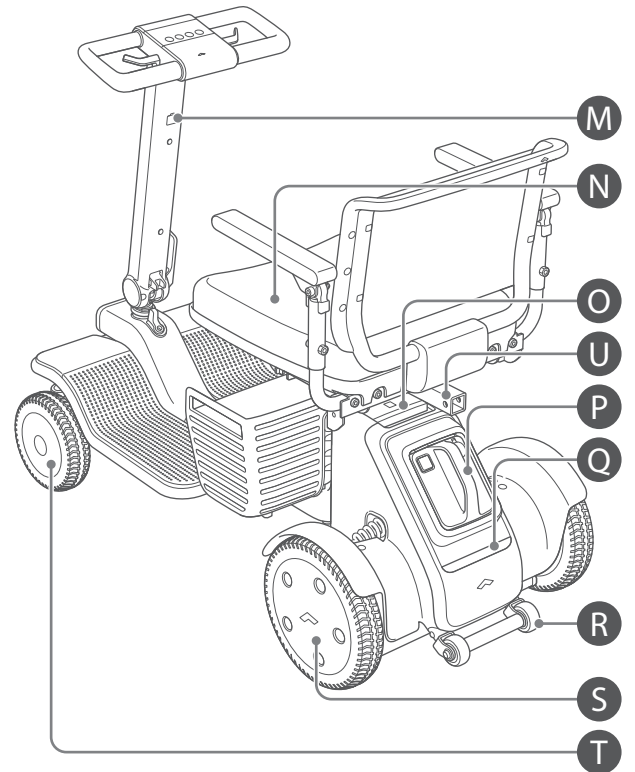
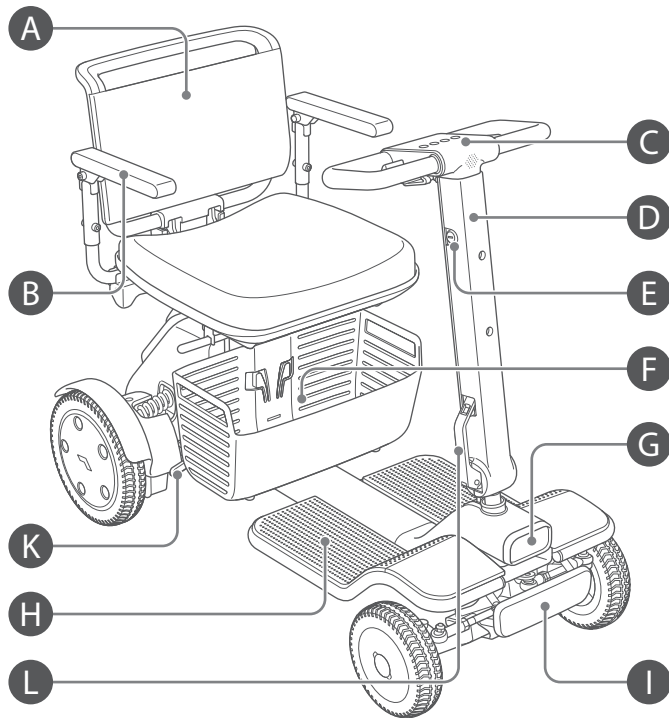

2

3-Wheel type

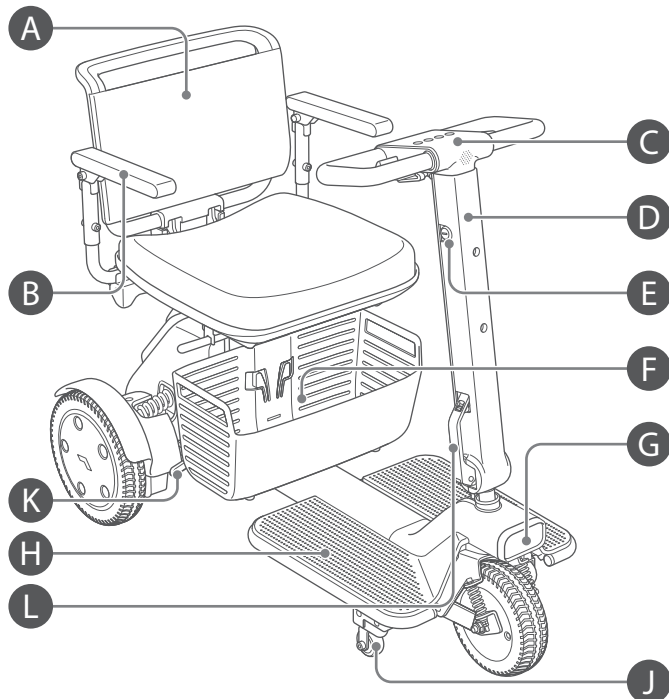

- A Back support**
- B Armrests**
- C Controller unit**

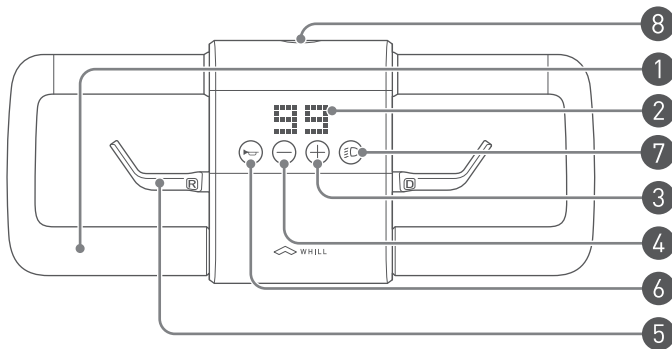

- 1 Tiller handle**
- 2 Display**
- 3 Speed select button "+"**
Increases the maximum speed.
- 4 Speed select button "-"**
Decreases the maximum speed.
- 5 Throttle control lever**
This device moves forward when the right lever is pulled, and moves backward when the left lever is pulled. When the lever is returned to its original position, this device decelerates and comes to a stop. The speed can be adjusted within the range of the preset maximum speed depending on how far the lever is pulled towards you.
- 6 Horn button**
Pressing this button sounds the alarm tone.
- 7 Front light button**
Switches the front light ON and OFF.
- 8 Speaker**

- D Tiller unit**
The tiller unit comprises the controller unit and tiller that is used as the shaft.

- E Key cylinder**

- F Basket**

- G Front light**

Lights simultaneously with power ON. The front light can be switched OFF and ON by the front light button on the controller unit.

- H Footrest**

- I Front bumper *4-wheel type only**

- J Anti-tip rollers (front) *3-wheel type only**

- K Brake release lever**

This lever is for locking/unlocking the brakes when moving this device manually. For details, refer to "5.6. Releasing the brakes" on page 77.

- L Tiller adjustment lever**

Lever for adjusting the angle of the tiller unit. For details, refer to "3.4.1. Adjusting the tiller unit angle" on page 40.

- M USB port (Type-C)**

- N Seat cushion**

- O Frame release lever**

For details, refer to "3.5.5. Removing the drive base" on page 51.

- P Battery**

For details, refer to "4.1. Battery and charger" on page 55.

- Q Rear light**

Lights simultaneously with power ON.

- R Anti-tip rollers (rear)**

- S Rear wheels**

- T Front wheels**

- U Accessory mount**

This securing fixture is for attaching accessories. Attach only authentic or designated accessories. For details, refer to "2.4. Accessories" on page 24.

■ Charger

For details, refer to "4.1. Battery and charger" on page 55.

Information labels

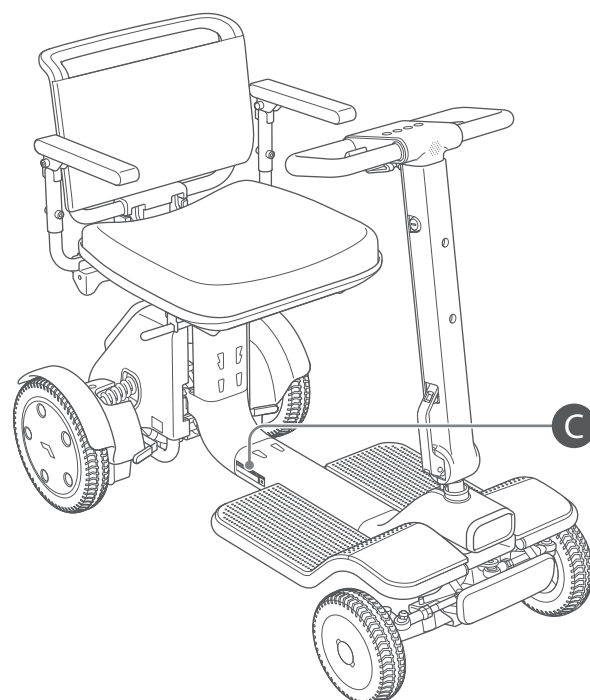
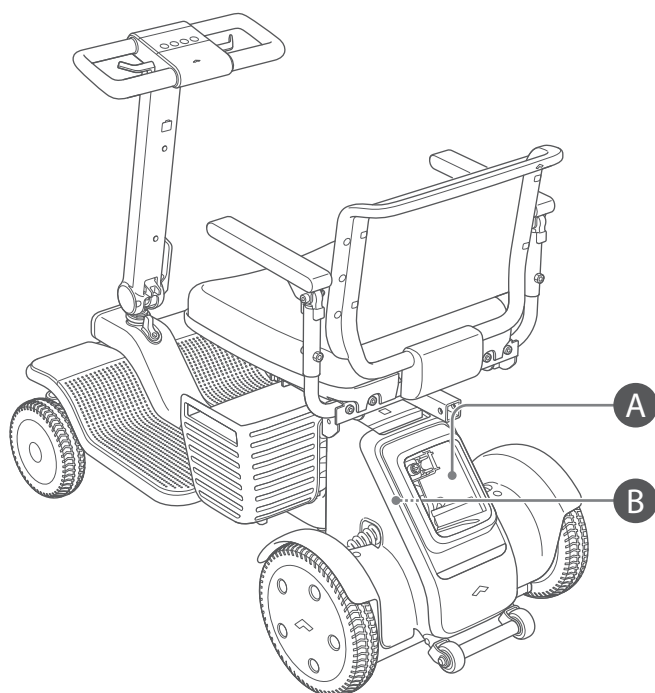

2

A Primary identification label

Indicates the serial number and UDI (Unique Device Identifier). When contacting the distributor or customer support, check the serial number by referring to this label or C. Serial number label.

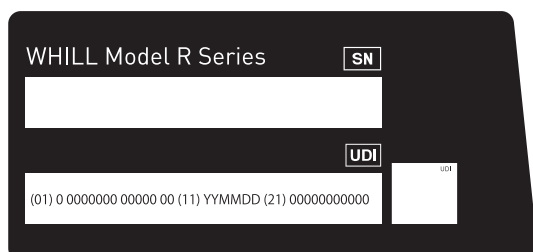

C Serial number label

Indicates the serial number for drive base.

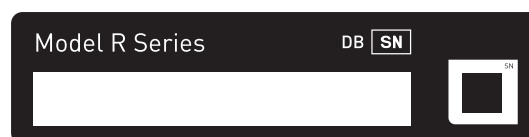

B Manufacturer information label

Indicates the manufacturer and manufacturer's address.



2.4. Accessories

Be sure to use only authentic or designated accessories.

For the accessories that can be installed onto this device, contact your distributor or customer support. Accessories can also be checked on the WHILL Website (<https://whill.inc>).

3. Assembly, adjustment and disassembly

This section explains how to assemble and disassemble the device, and how to adjust each part.

Assemble this device in the order described in this user manual.

WARNING



- **Take care not to drop the battery and charger when removing them from the box or installing them on this device.**
Otherwise, there is a risk of unexpected accidents such as injury or the battery being damaged or igniting.
- **Perform assembly on a flat and level surface.**
Otherwise, there is a risk of accident.
- **Before performing adjustments, turn the power supply OFF, and apply the brakes on a flat and level surface.**
Otherwise, there is a risk of accident.
- **Before disassembly, apply the brakes on a flat and level surface, and remove the battery.**
Otherwise, there is a risk of injury or electric shock, or unexpected accident.



- **Assemble, adjust and disassemble this device in the order described in this user manual. Do not perform any adjustment, repair, or modification that is not listed in this manual.**
There is a risk of injury and product safety risk due to damage to this device or its parts. Performing repair or modification which is not listed in this manual will invalidate the warranty.
- **Do not perform assembly in a wet environment or if this device is wet.**
Otherwise, there is a risk of injury or electric shock and of damage to this device or its parts.
- **When removing this device from the box, firmly hold it and take care not to drop it or let it tip over.**
There is a risk of injury to the user and damage to parts as a result of falling.



If you cannot perform assembly or adjustment by yourself, contact your distributor or customer support.

3.1. Names of parts

The following parts are packaged with this device.

- Drive base

The type you selected will be packaged. The type available may differ according to country or region.

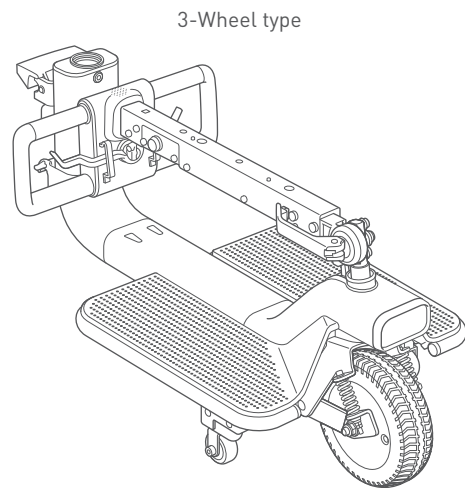
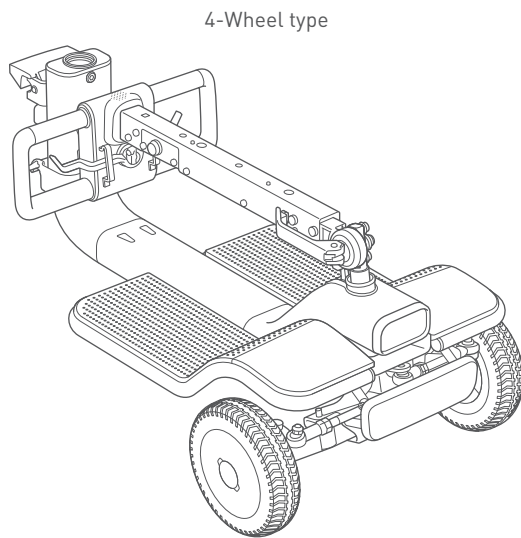

- Main body

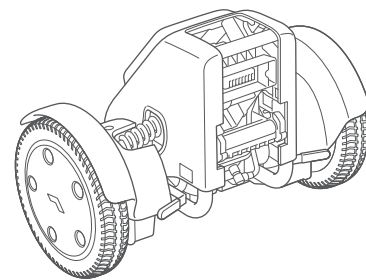

- Seat post

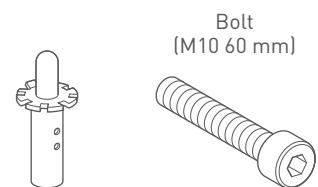

- Tiller cover (front)

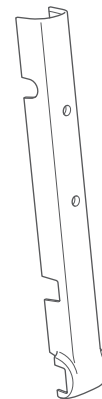

- Tiller cover (rear)

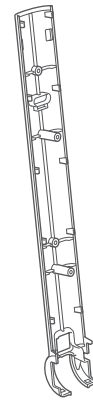

Bolt
(M4 12 mm) x 4



3

- Basket

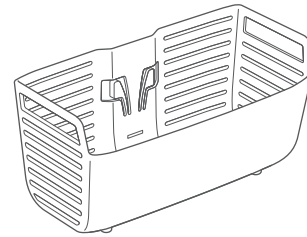

- Seat base

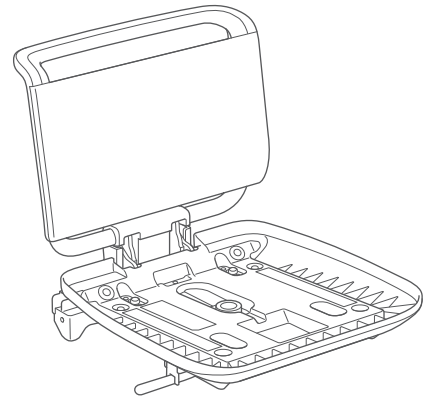

- Seat cushion

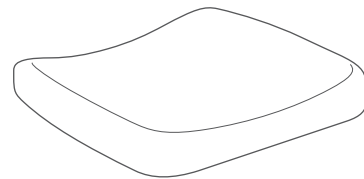

- Armrests

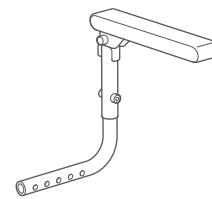
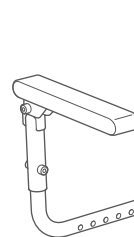

Bolt
(M8 30 mm) x 4

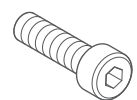

- Battery

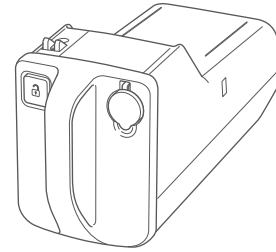

- Charger

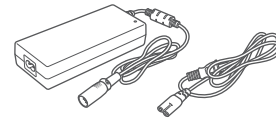

- Mechanical key

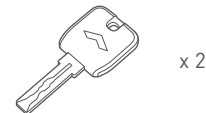

3.2. Required tools

Use the following tools for assembling and adjusting this device. The tools are not provided with this device.

1. Hex wrench 3 mm, 6 mm, 8 mm

3.3. Assembly procedures

When assembling this device, pay close attention to the following points.

WARNING



- **Perform assembly on a flat and level surface.**
Otherwise, there is a risk of accident.
- **Do not touch the battery connector socket or battery connector port directly, allow them to become wet, or bring foreign objects close to them. When inserting the battery, ensure that there are no foreign objects attached.**
Otherwise, there is a risk of injury or electric shock and of damage to this device or its parts.
- **Do not touch the drive base connector socket or main body connector port directly, allow them to become wet, or bring foreign objects close to them. When assembling, ensure that there are no foreign objects attached.**
Otherwise, there is a risk of injury or electric shock and of damage to this device or its parts.
- **Perform work with the battery removed.**
Otherwise, there is a risk of injury, electric shock or unexpected accident due to this product moving unexpectedly.



- **Do not press a sharp object against or apply a load to the cables.**
A damaged cable may cause malfunctions or unexpected movement.
- **Do not disassemble any part not described in this manual.**
There is a risk of device malfunction.

⚠ CAUTION



- When assembling, be careful that your fingers do not become caught. Also, do not exert unnecessary force.
There is a risk of injury to the user and damage to parts.
- Pay attention to the following points and perform adjustment in order to ensure safe use. Otherwise, there is a risk of accident.
 - Where adjustments can be made, first adjust this device to an easy-to-use position and angle.
 - When performing assembly and adjustments, tighten the bolts at the specified tightening torque. If a tool whose torque can be controlled is not available, firmly tighten the bolts so that they are not loose.
 - Before performing assembly or adjustments, be sure to get off this device.
- The weight of the drive base, main body, seat, and battery are as follows. When assembling, take care not to drop these parts.
There is a risk of injury to the user and damage to parts.
 - Drive base
 - 3-wheel type: 16.3 kg (35.9 lbs.)
 - 4-wheel type: 20.9 kg (46.1 lbs.)
 - Main body 20.3 kg (44.8 lbs.)
 - Seat 12 kg (26.5 lbs.)
 - Battery 2.7 kg (6 lbs.)



- Do not scratch or allow dirt to stick to the display of the controller unit.
There is a risk that the display may become damaged or illegible.

3

3.3.1. Assembling the drive base and main body



This assembly cannot be performed with the battery inserted on the main body. Be sure to remove the battery before assembly.

1. Hold the frame release lever of the drive base and the footrest frame at the front, and move the drive base to in front of the main body.

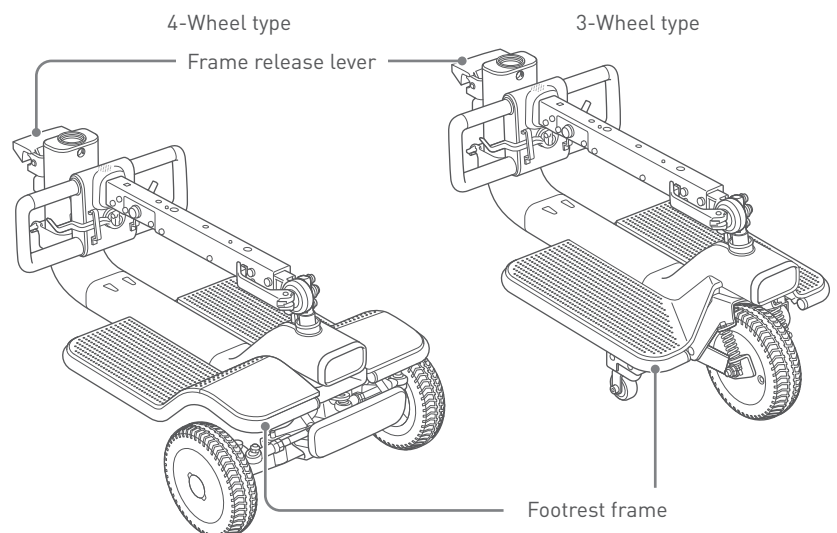

2. Align frame hook A of the drive base with frame tube A of the main body. At this time, check that the protrusion on both sides of frame hook A of the drive base is aligned with the black safety lock at frame tube A of the main body.

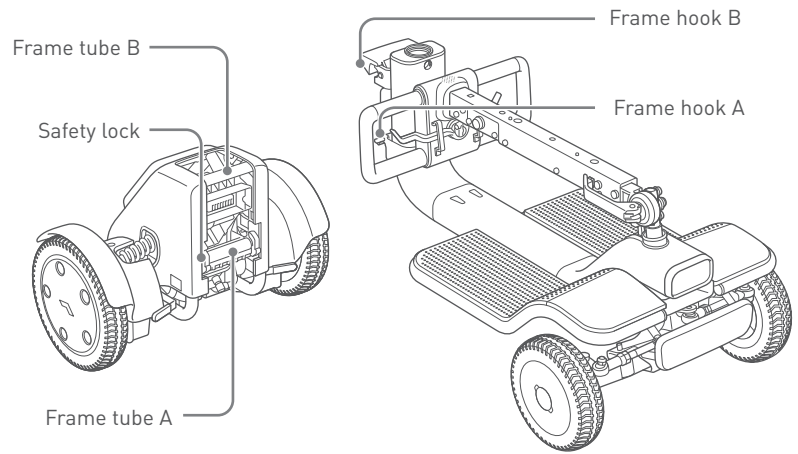

3. Push in the drive base downwards, and align frame hook B of the drive base with frame tube B of the main body.
4. Release your hand from the frame release lever of the drive base, and attach the drive base to the main body. Lightly push the frame release lever from above, and check that the drive base and main body are installed correctly.

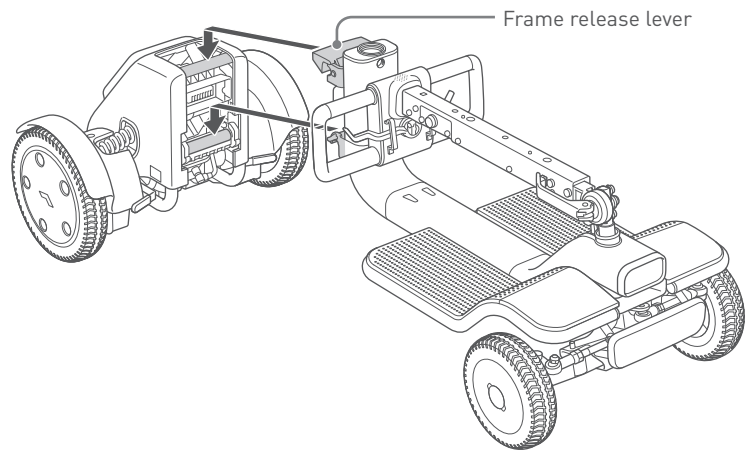

 Warning

Inserting a finger

or other body part into the connecting components and moving parts of this device may result in an injury.

When assembling, adjusting, and transporting this device, do not touch any component other than those indicated in the manual.





Be sure to check that the frame release lever is locked correctly.

When the frame release lever is in the up position as shown in the "Semi-locked state" in the figure below, it is not locked correctly. Push the frame release lever from above to set it to the "Locked state". The connection part of the frame release lever can be slanted slightly down into the drive base when it is engaged firmly.

If the frame release lever is not set to the "Locked state" even by pushing from above, remove the drive base and main body temporarily, and check that there are no foreign objects attached to each of the tubes and hooks.

Correct: Locked state

Incorrect: Semi-locked state

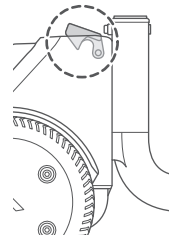
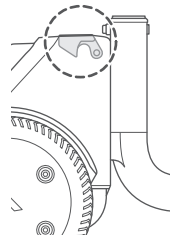

3

3.3.2. Unfolding the tiller unit

1. Push down the lock of the tiller adjustment lever on the right side of the tiller unit, and pull the tiller adjustment lever.



Be sure to unlock the tiller adjustment lever before raising the lever. There is a risk of damage to parts if the lever is not unlocked and excessive force is applied.

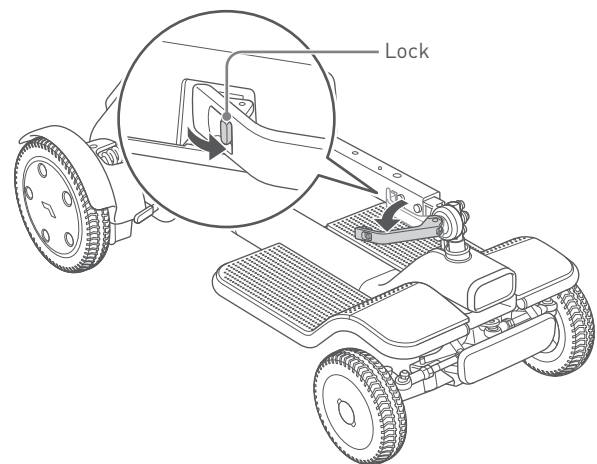

2. Lift up the tiller unit while holding the handle, and tighten the tiller adjustment lever at an easy-to-use angle. Insert the hook at the end of the tiller adjustment lever into the inside of the lever fixing hole on the frame, and lock the lever.

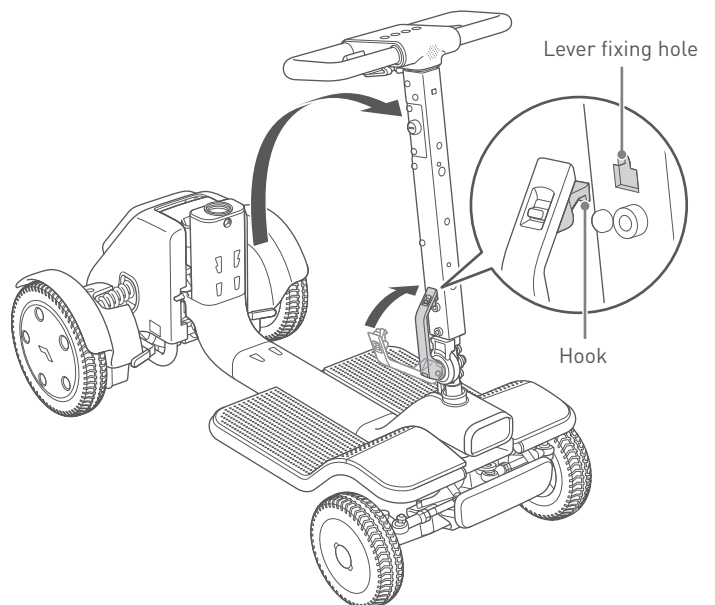

Warning

Inserting a finger or other body part into the connecting components and moving parts of this device may result in an injury.

When assembling, adjusting, and transporting this device, do not touch any component other than those indicated in the manual.



3.3.3. Installing the tiller cover

1. Install the tiller cover (rear) to the rear of the tiller.

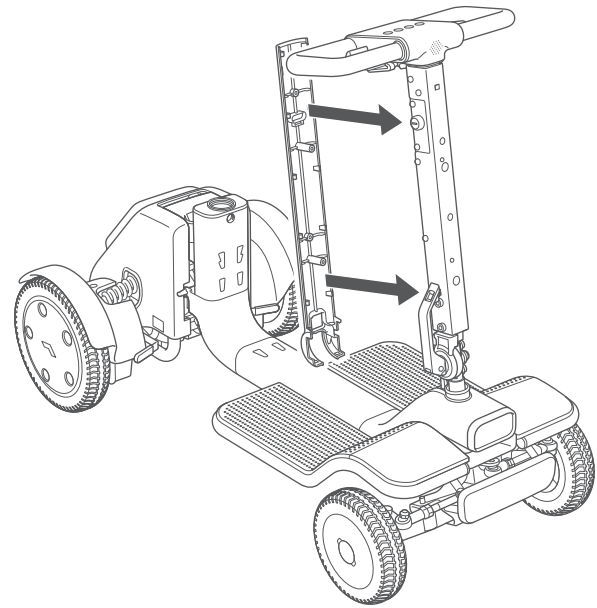

3

2. Install the tiller cover (front) to the front of the tiller.

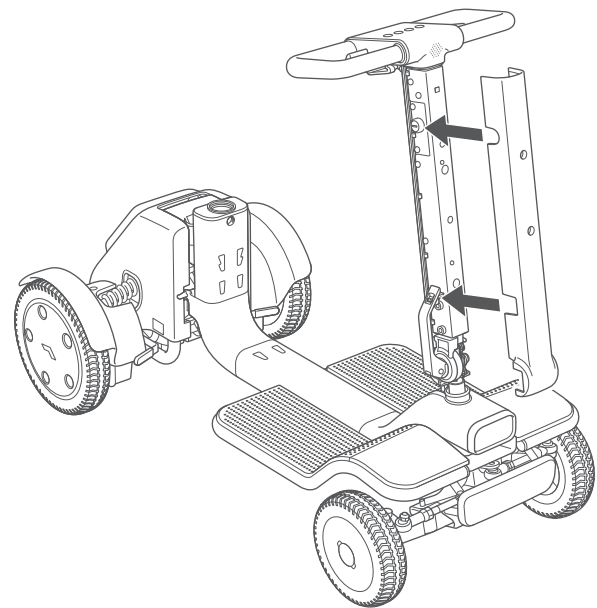

3. Secure the 4 locations on the rear with bolts (M4 12 mm).

Tool: hex wrench (3 mm)

Tightening torque: 2 Nm



Do not use excessive force to install the tiller cover or excessive torque to tighten the bolt. There is a risk of damaging parts.

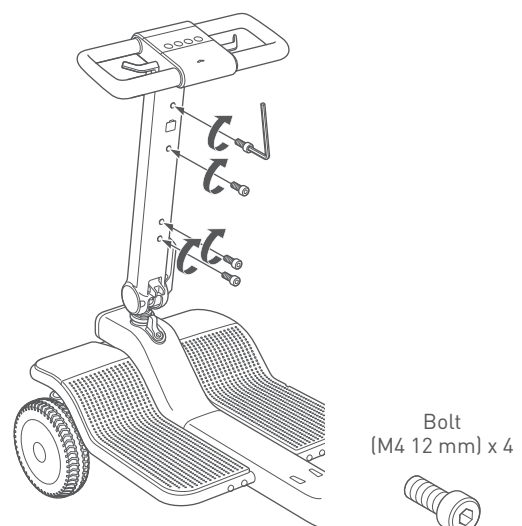

3.3.4. Installing the seat post

1. Set the seat rotation stopper at the gear-shaped part of the seat post to face the rear of this device, insert the stopper into the drive base, and secure in place with the bolt (M10 60 mm).

Tool: hex wrench (8 mm)

Tightening torque: 25 Nm

3



- The seat post must be installed in the correct orientation. The seat base can only be installed correctly if the seat rotation stopper is installed facing the rear of this device.
- The seat height can be adjusted in 2 stages. Adjust the position for securing the seat post to set the seat to the appropriate height so that the user can get in and drive this device at the correct posture. For details on how to adjust, refer to “3.4.2. Adjusting the seat height” on page 41.

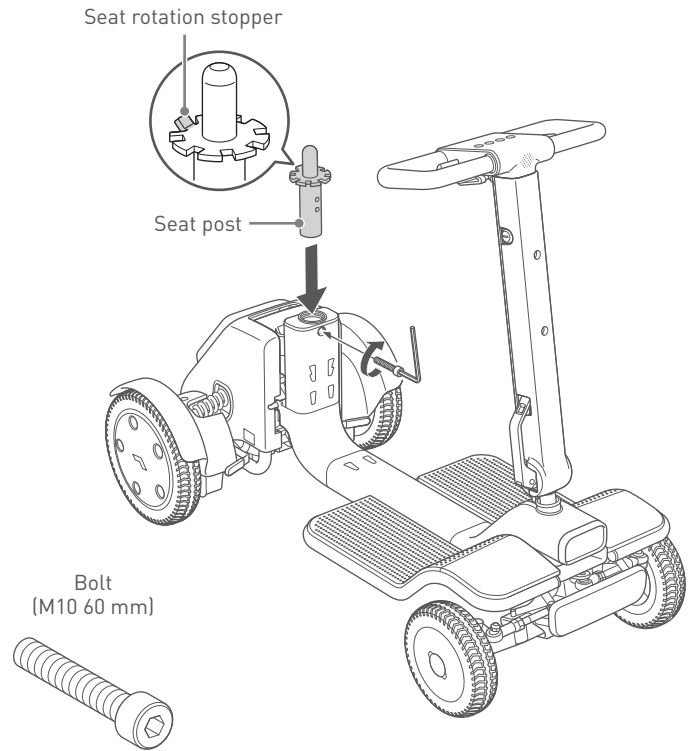

3.3.5. Installing the basket

1. Insert the basket hooks (2 locations) on the bottom rear side of the basket into the basket mounting holes (2 locations) on the base of the drive base.

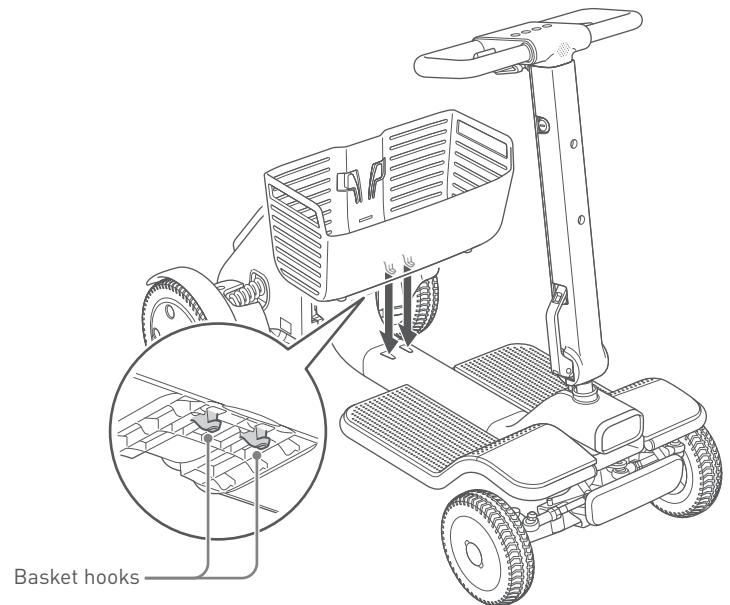

2. Take the basket hooks (2 locations) on the inner side of the basket between your fingers, and insert the ends of the basket hooks into the basket mounting holes (2 locations) on the inside of the drive base and secure in place.

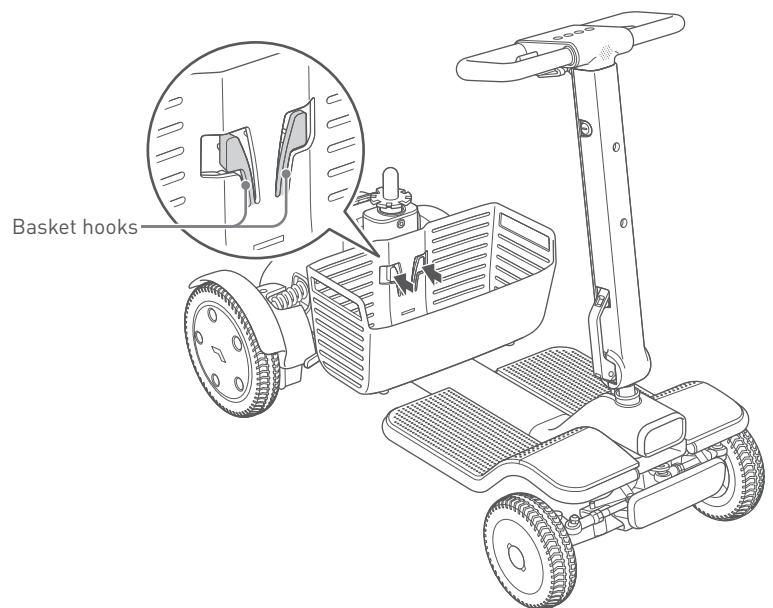

3.3.6. Installing the seat base

1. Attach the seat base to the seat post. Check the position of the seat post from the viewing hole on the seat base, and insert the end of the seat post into the viewing hole.

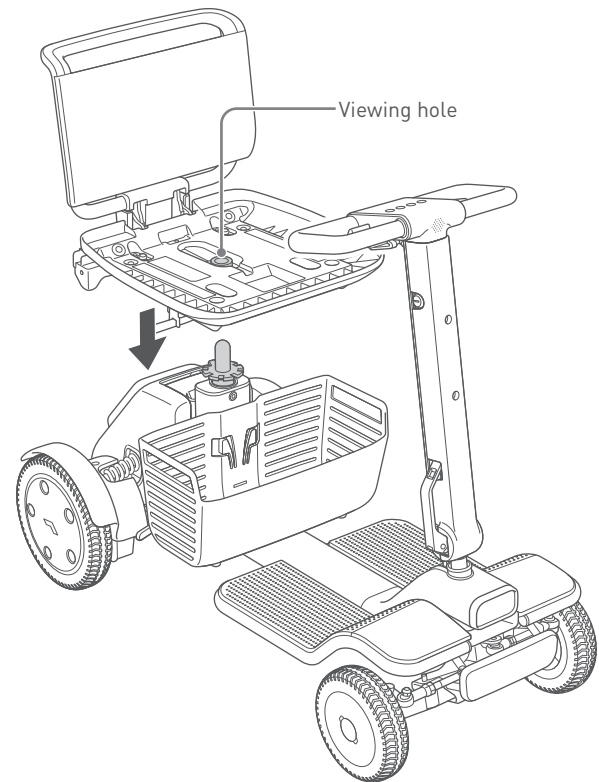

3

3.3.7. Installing the seat cushion onto the seat

1. Attach the seat cushion onto the seat assembly. Secure the seat cushion and seat base in place with each of their hook and loop fasteners aligned.

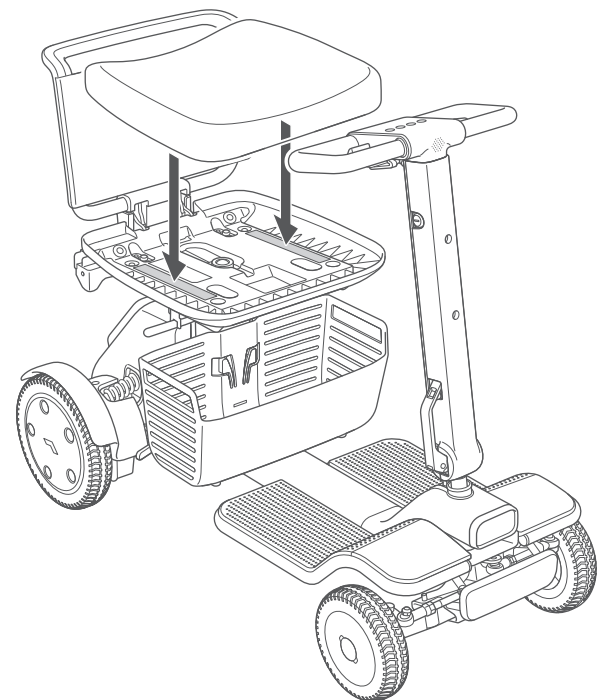

3.3.8. Installing the armrests

1. Insert the armrest into the seat frame, and secure the 2 locations with bolts (M8 30 mm).
2. Install the other armrest in the same way.
Tool: hex wrench (6 mm)
Tightening torque: 12.5 Nm



The height of the armrests and space between them can each be adjusted in 3 stages. Adjust the height and width of the armrests so that the user can get in and drive this device at the correct posture. For details on how to adjust, refer to "3.4.4. Adjusting the space between armrests" on page 45 and "3.4.5. Adjusting the height of the armrest" on page 46.

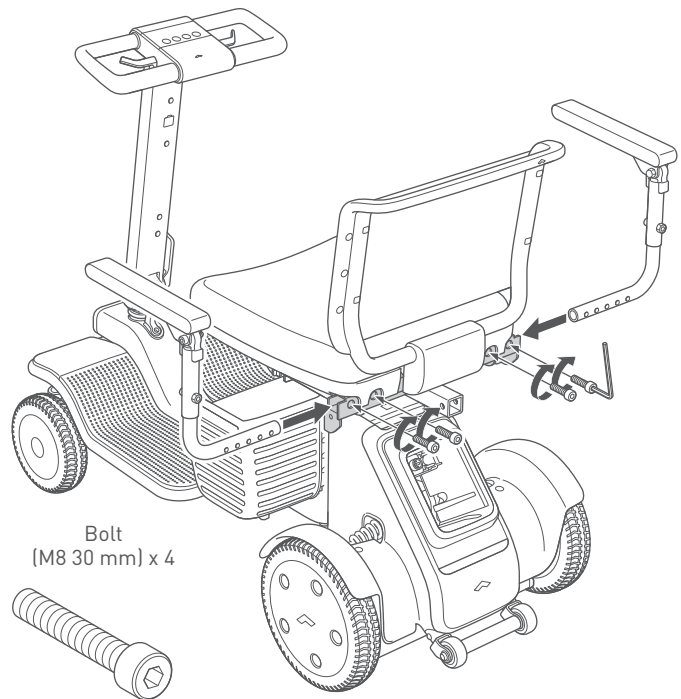

3.3.9. Installing the battery

WARNING



- Do not touch the battery connector socket or battery connector port directly, allow them to become wet, or bring foreign objects close to them. When inserting the battery, ensure that there are no foreign objects attached.
Otherwise, there is a risk of injury or electric shock and of damage to this device or its parts.
- The battery and charger are both for this device only. Do not charge the battery by using a non-designated charger or charge non-designated batteries with the charger provided with this device.
Otherwise, there is a risk of unexpected accident such as malfunction or the battery igniting or exploding.
- Do not use batteries with the battery charging port cap damaged or cracked.
There is a risk of a short circuit caused by liquid or foreign objects getting inside.

CAUTION



- If this device is not used for a long period, fully charge the battery before storing. Charge the battery at least once a month.
There is a risk that the battery may get excessively depleted and cannot be charged.
- Be sure to close the battery charging port cap when the battery charging port is not in use.
There is a risk of a short circuit caused by liquid or foreign objects getting inside.

i

- If this device does not start up after five seconds, please check that the battery is charged and properly inserted, and the power is turned ON. If the device will still not start, remove the battery, and then attach the battery again after 10 seconds have elapsed.
- If this device does not start up even after removing and inserting the battery several times, there is the risk that the device or battery is malfunctioning. Contact your distributor or customer support.

3

1. Check that the mechanical key is not inserted into the key cylinder on the right side of the tiller unit.
2. Check that the battery lock release button is not pressed.

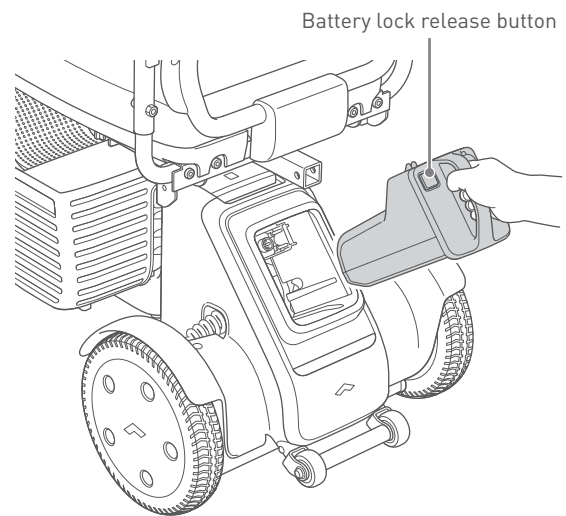

3. Grip the battery handle, and insert the battery straight until it clicks in place in the battery compartment. When it is difficult to insert the battery, push it from the front with force.

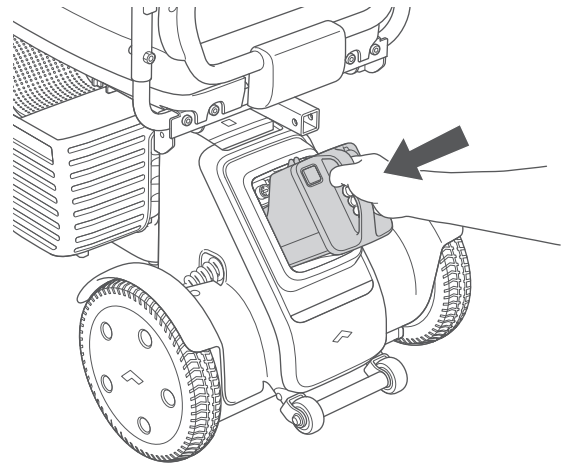
**i**

- Charge the battery before using this device for the first time.
- For the battery charging procedure, refer to “4.2. Charging procedures” on page 55. The battery weighs 2.7 kg (6.0 lbs.). Take care not to drop the battery. Otherwise, there is a risk of injury or the battery being damaged or igniting.
- If the battery cannot be inserted completely, foreign objects may be attached to the battery connector socket or battery connector port. If there are any foreign objects, remove them with a small brush, etc.

3.4. Adjustment procedures

The following device adjustments can be made to meet the user's seating needs.

- Angle of tiller unit: "3.4.1. Adjusting the tiller unit angle" on page 40
- Seat height: "3.4.2. Adjusting the seat height" on page 41
- Seat forward/backward position: "3.4.3. Adjusting the seat forward/backward position" on page 43
- Space between armrests: "3.4.4. Adjusting the space between armrests" on page 45
- Height of armrest: "3.4.5. Adjusting the height of the armrest" on page 46

WARNING



- **Before performing adjustments, turn the power supply OFF, and apply the brakes on a flat and level surface.**

Otherwise, there is a risk of accident.



- **Do not press a sharp object against or apply a load to the cables.**

A damaged cable may cause malfunctions or unexpected movement.

CAUTION



- **When adjusting, be careful that your fingers do not become caught. Also, do not apply excessive force.**

There is a risk of injury to the user and damage to parts.

- **Pay attention to the following points and perform adjustment in order to ensure safe use.**

Otherwise, there is a risk of accident.

- Where adjustments can be made, first adjust this device to an easy-to-use position and angle.
- When performing assembly and adjustments, tighten the bolts at the specified tightening torque. If a tool whose torque can be controlled is not available, firmly tighten the bolts so that they are not loose.
- Before performing assembly or adjustments, be sure to get off this device.



- **Do not scratch or allow dirt to stick to the display of the controller unit.**

There is a risk that the display may become damaged or illegible.

3.4.1. Adjusting the tiller unit angle

1. Hold the tiller handle and support the tiller unit.
2. Push down the lock of the tiller adjustment lever on the right side of the tiller unit, and pull the tiller adjustment lever.

3

i

- Raise the tiller adjustment lever while holding the handle. There is the risk of damage to the controller unit and the user being injured because of the tiller unit falling over.
- Be sure to unlock the tiller adjustment lever before raising the lever. There is a risk of damage to parts if the lever is not unlocked and excessive force is applied.

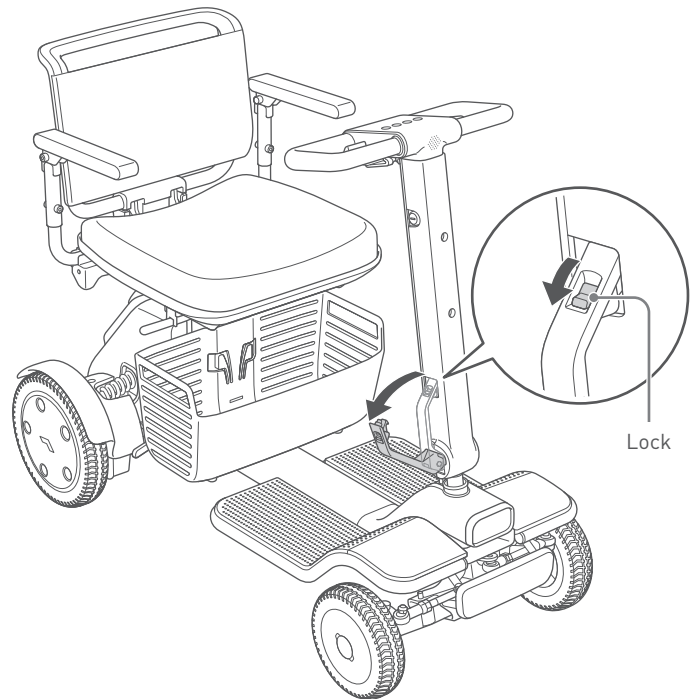

3. Adjust the tiller unit to an easy-to-use angle.

i

If the tiller unit is pulled down by a considerable amount, the handle will slide to the outside when this device is turned, and the minimum turning radius will increase.

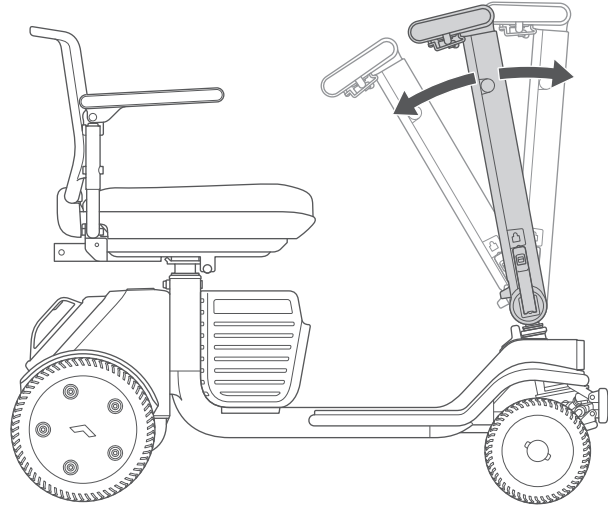

4. Tighten the tiller adjustment lever, and insert the hook at the end of the tiller adjustment lever into the inside of the lever fixing hole on the frame, and lock the lever.

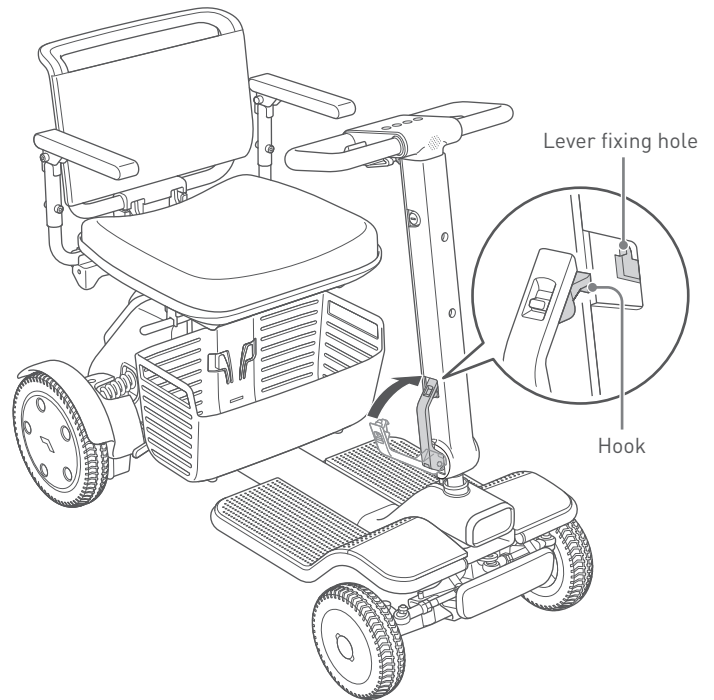

3.4.2. Adjusting the seat height

1. Remove the battery.
For the removal procedure, refer to "3.5.1. Removing the battery" on page 48.
2. Remove the seat assembly.
For the removal procedure, refer to "3.5.2. Removing the seat assembly" on page 49.
3. Remove the basket.
For the removal procedure, refer to "3.5.3. Removing the basket" on page 49.
4. Loosen the bolt (M10 60 mm), and remove the bolt while supporting the seat post.
Tool: hex wrench (8 mm)
Tightening torque: 25 Nm

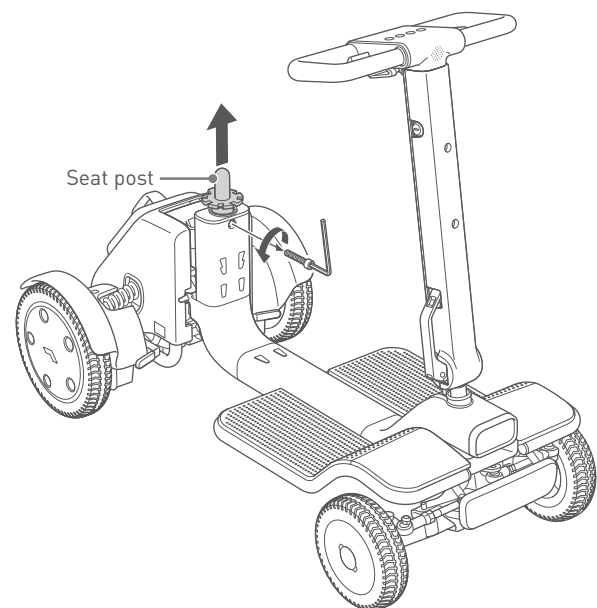

5. Change the position of the hole to align the seat post to an easy-to-use height.



The height of the seat from the footrest can be adjusted in 2 stages.

3

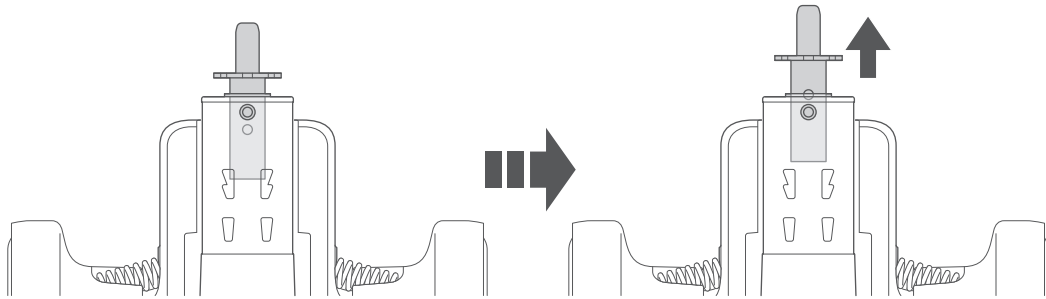

6. Tighten the seat post bolt (M10 60 mm) to secure the height of the seat post.

For details on how to secure, refer to “3.3.4. Installing the seat post” on page 34.

Tool: hex wrench (8 mm)

Tightening torque: 25 Nm

7. Remove the seat cushion from the seat so that the viewing hole on the seat base is visible.

8. Attach the seat base to the seat post.

For the installation procedure, refer to “3.3.6. Installing the seat base” on page 36.



When holding the seat, do not hold the armrests. The armrests cannot be held firmly as they move. There is a risk of damage or injury as a result of falling.

9. Attach the seat cushion onto the seat assembly. Secure the seat cushion and seat base in place with each of their hook and loop fasteners aligned.

3.4.3. Adjusting the seat forward/backward position

1. Remove the seat cushion from the seat base.
2. Remove the seat base bolts (M6 15 mm) at four locations on the base of the seat base.

Tool: hex wrench (6 mm)

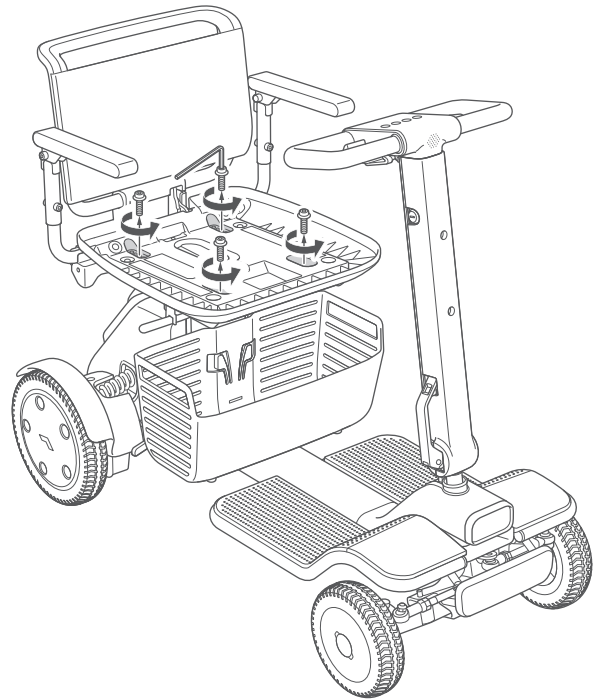

3. Change the position of the holes on the seat base to your preferred forward/backward position.



- The seat forward/backward position can be adjusted in 4 stages.
- Setting of this position can be checked by the number indicated on the seat base.
1: Front (maximum)
4: Back (maximum)

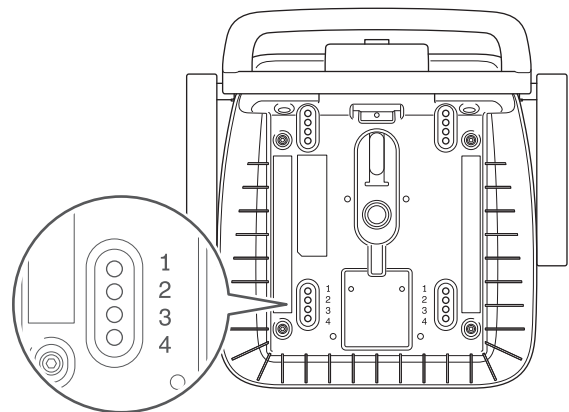

4. After determining the forward/backward position of the seat base, temporarily tighten the four locations with bolts (M6 15 mm). Then, firmly tighten to secure the seat base and seat frame in place.

Tool: hex wrench (6 mm)

Tightening torque: 15 Nm



Check that the seat base and seat frame are firmly secured.

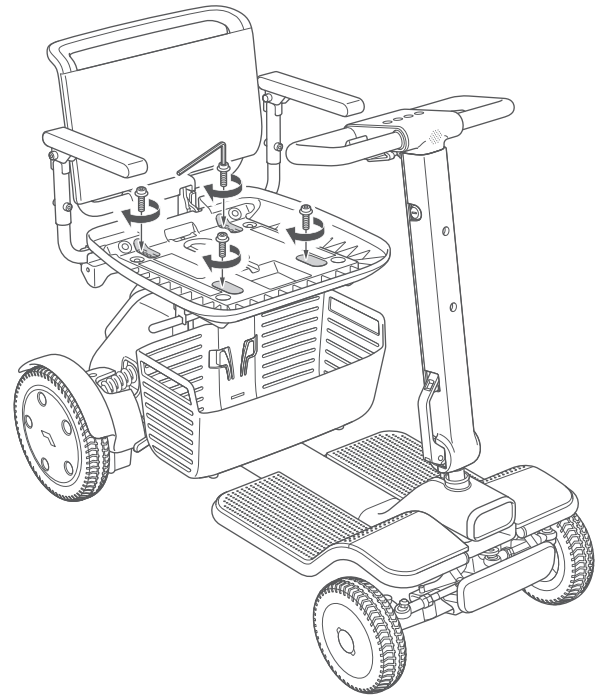

5. Attach the seat cushion onto the seat assembly. Secure the seat cushion and seat base in place with each of their hook and loop fasteners aligned.

3.4.4. Adjusting the space between armrests

1. Remove the two armrest bolts (M8 30 mm) from one side of the seat frame.

Tool: hex wrench (6 mm)

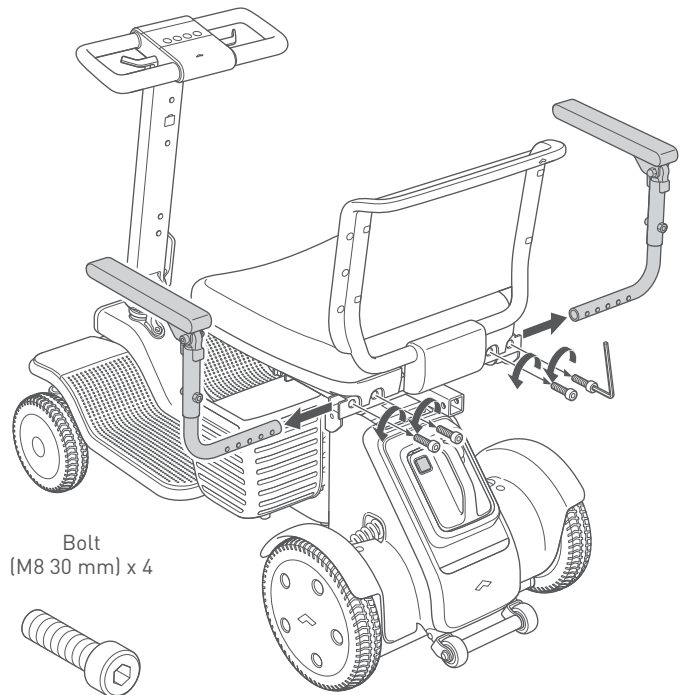

3

2. Change the position of the holes to your preferred spacing.



- The space between armrests can be adjusted in 3 stages.
- For details on setting of positions, refer to the number in the figure.
1: Narrow (minimum)
3: Wide (maximum)

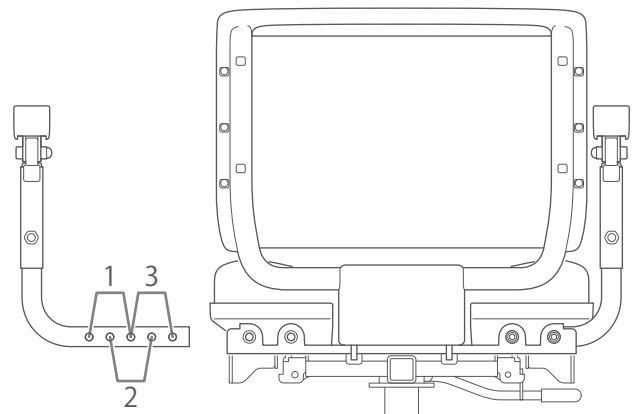

3. After determining the spacing between the armrests, secure the two bolts (M8 30 mm) in the updated positions.

For details on how to secure, refer to “3.3.8. Installing the armrests” on page 37.

Tool: hex wrench (6 mm)

Tightening torque: 12.5 Nm

4. Adjust the other armrest in the same way.

3.4.5. Adjusting the height of the armrest

1. Remove the bolt (M8 30 mm) of the armrest pipe.

Tool: hex wrench (6 mm)

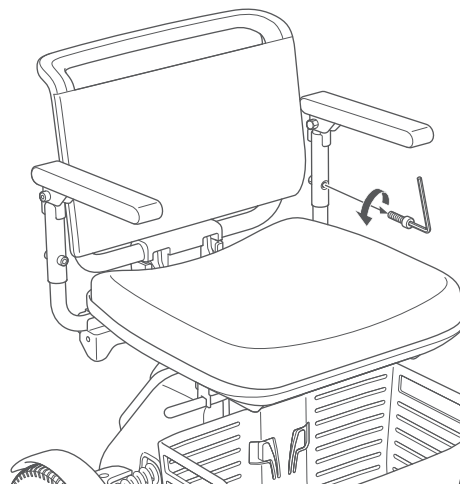

2. Change the position of the hole to your preferred height.



The height of the armrests can be adjusted in 3 stages.

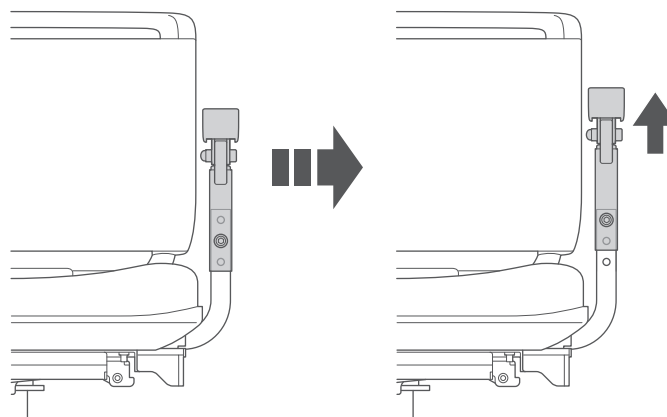

3. After determining the height of the armrest, secure with the bolt (M8 30 mm).

Tool: hex wrench (6 mm)

Tightening torque: 12.5 Nm

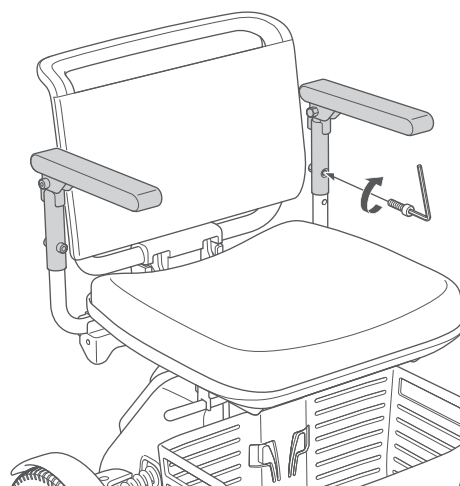

4. Adjust the other armrest in the same way.

3.4.6. Adjusting the light angle of the front light

1. Turn the front light ON, and check the light angle.
2. When adjustment is required, slowly move the light angle adjustment lever under the front light within its movable range to adjust the light angle.

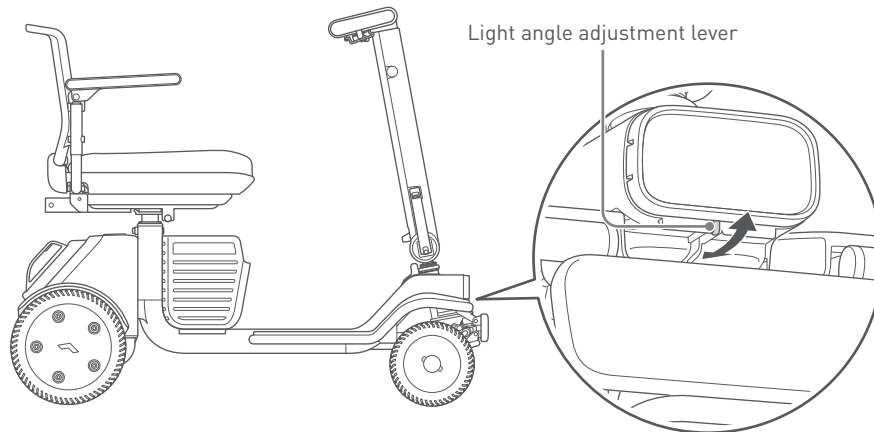

3

3.5. Disassembly procedures

This device can be disassembled into four main components (main body, drive base, seat, and battery) so that it can be transported by car or similar vehicle.

Disassembly of this device does not require tools. When disassembling this device, pay careful attention to the following points.

For methods of transporting the disassembled parts, refer to "6.2. Transporting this device" on page 81.

⚠ WARNING



- Perform disassembly on a flat and level surface with the brakes applied. Otherwise, there is a risk of accident.

- Remove the battery before performing disassembly. Otherwise, there is a risk of injury or electric shock and of damage to this device or its parts.



- Do not touch the battery connector socket or battery connector port directly, allow them to become wet, or bring foreign objects close to them. Otherwise, there is a risk of injury or electric shock and of damage to this device or its parts.

- Do not touch the drive base connector socket or main body connector port directly, allow them to become wet, or bring foreign objects close to them. Otherwise, there is a risk of injury or electric shock and of damage to this device or its parts.

⚠ CAUTION



- Hold only locations described in this manual when disassembling the device. Do not hold other locations. There is a risk of hand injury if it gets caught in this device.

3.5.1. Removing the battery

1. Turn the device power supply OFF. If the brake is released, pull the brake release levers upwards to apply the brakes.
2. Press the battery lock release button, and remove the battery by holding its handle.

Battery lock release button

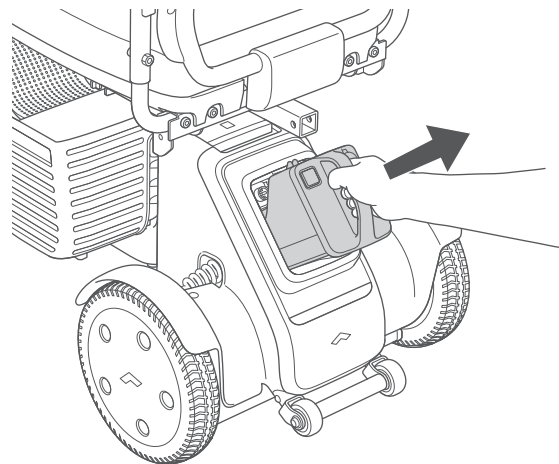
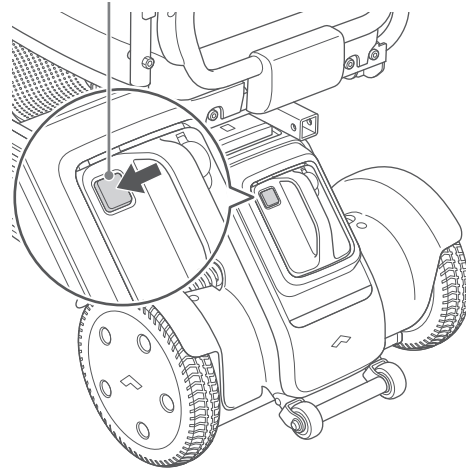

3.5.2. Removing the seat assembly

1. Hold both sides of the seat base, and lift the seat straight upwards to remove it from the seat post.



When holding the seat, do not hold the armrests. The armrests cannot be held firmly as they move. There is a risk of damage or injury as a result of falling.

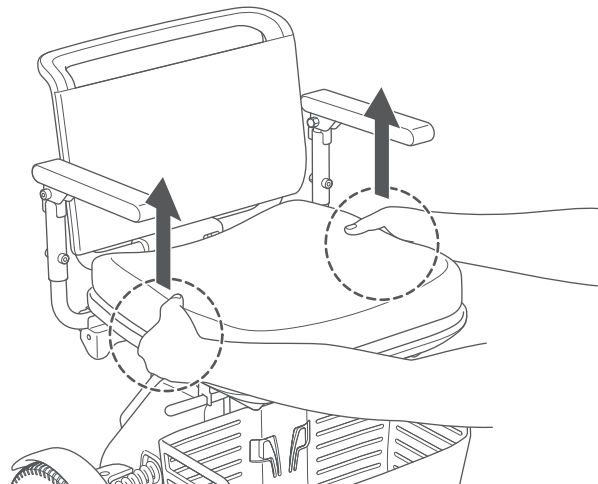

3

3.5.3. Removing the basket

1. Remove all items in the basket.
2. Take the basket hook on the inner side of the basket between your fingers, tilt the basket at an angle, and remove the protrusions (2 locations) of the basket hooks from the basket mounting holes (2 locations) on the inside of the drive base.

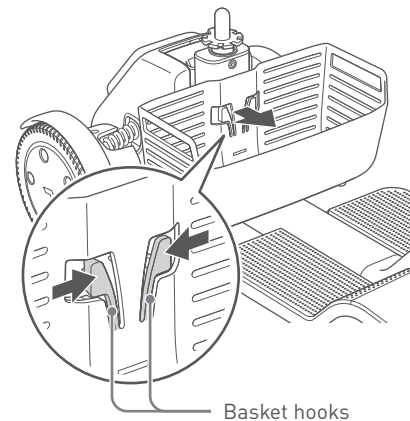

3. With the basket tilted at an angle, lift the basket straight up, and remove the basket hooks (2 locations) on the bottom rear side of the basket from the basket mounting holes (2 locations) on the base of the drive base.

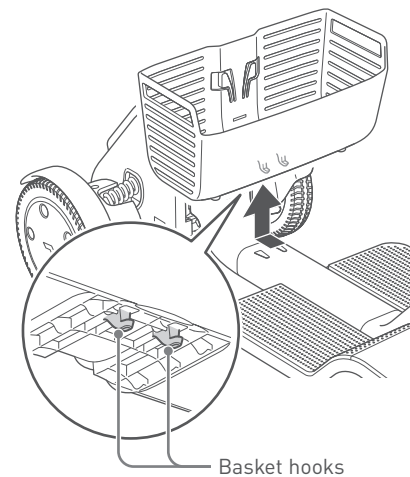

3.5.4. Folding the tiller unit

1. Hold the tiller handle and support the tiller unit.
2. Push down the lock of the tiller adjustment lever on the right side of the tiller unit, and pull the tiller adjustment lever.

3

i

- Raise the tiller adjustment lever while holding the handle. There is the risk of damage to the controller unit and the user being injured because of the tiller unit falling over.
- Be sure to unlock the tiller adjustment lever before raising the lever. There is a risk of damage to parts if the lever is not unlocked and excessive force is applied.

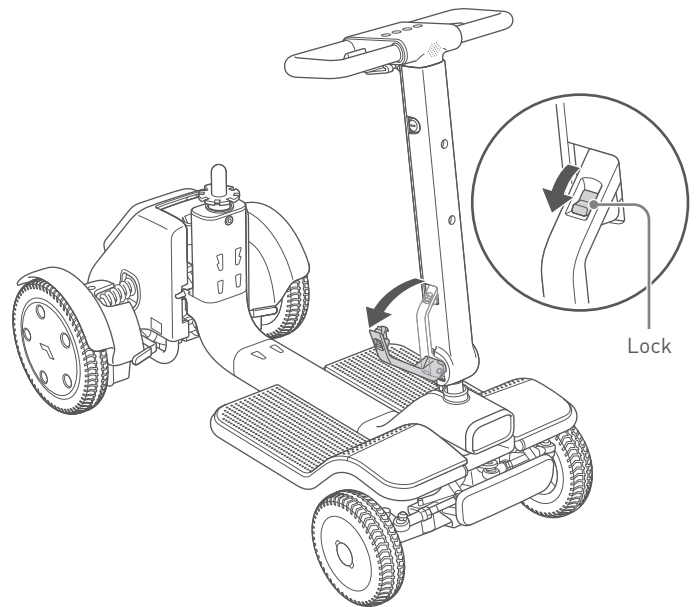

3. Fold the tiller unit, and align the tiller unit rotation stopper with the C-shaped protrusion on the tiller unit.

i

- Rotation of the tiller unit is secured in place by aligning the tiller unit rotation stopper with the C-shaped protrusion on the tiller unit.
- By securing the tiller unit, subsequent disassembly, transportation and assembly can be performed safely.

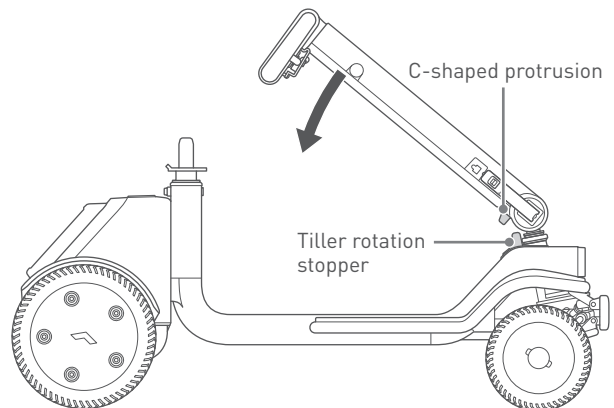

4. Tighten and secure the tiller adjustment lever in place. Insert the hook at the end of the tiller adjustment lever into the inside of the lever fixing hole on the frame, and lock the lever.

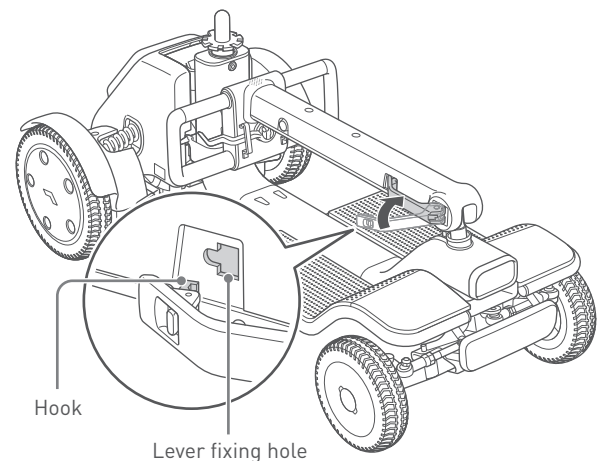

3.5.5. Removing the drive base

1. Hold the frame release lever of the drive base and the footrest frame at the front, and support the drive base with both hands.

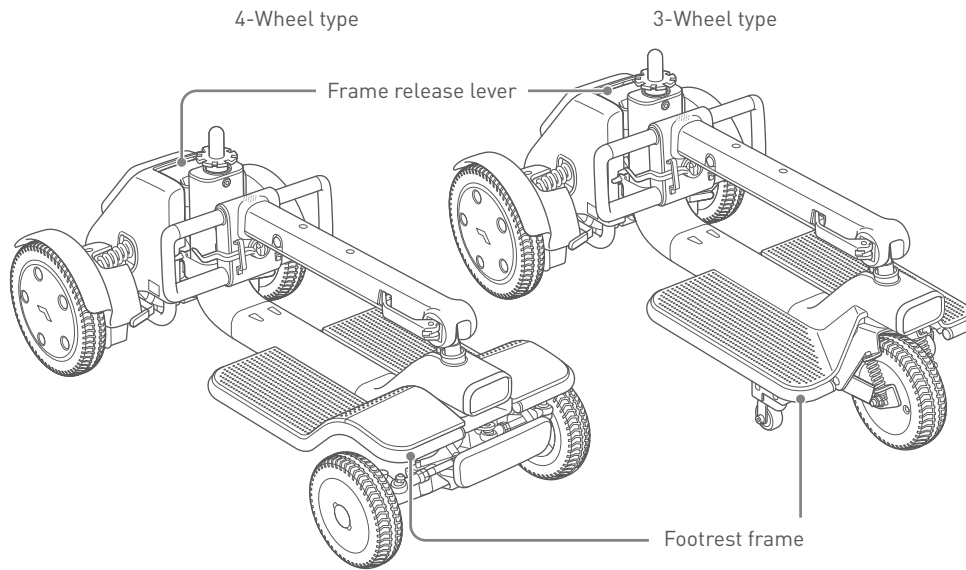

For safety, this device is designed so that the drive base cannot be removed with the battery inserted. Be sure to remove the battery before removing the drive base.

2. Lift the frame release lever upwards, and remove frame hook A and frame hook B of the drive base from frame tube A and frame tube B of the main body.

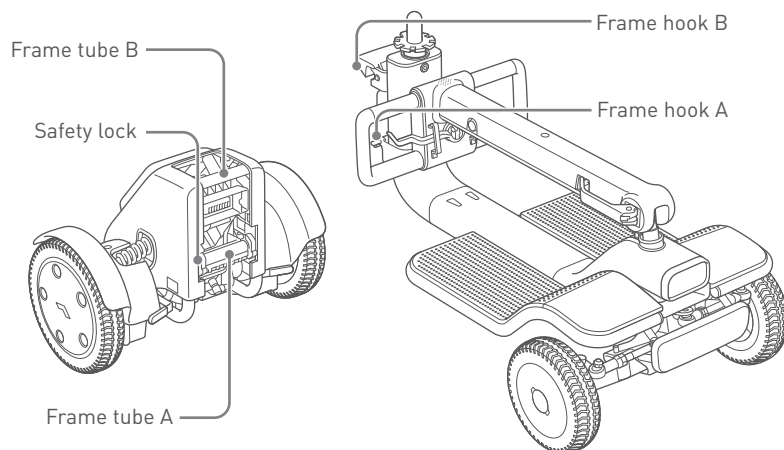

4. Charging the battery

Charge the battery before using this device for the first time.

Under ideal conditions, 4-wheel types can travel a maximum of 17.2 km (10.7 miles) and 3-wheel types can travel a maximum of 18.7 km (11.6 miles). The driving range of this device is affected and varies according to the roads and terrain it is driven on, load, ambient temperature, use of electric supply from the USB port, operating method, and other factors. To extend the driving range of this device, use this device while paying attention to the following.

- Fully charge the battery before use.
- Travel along routes with few steps and inclines.
- Reduce the weight of storage items.
- Refrain from using electric supply from the USB port.
- Maintain consistent speed and avoid sudden stops.

WARNING



- **Carefully read the explanations in this manual regarding the battery and charger, and follow the instructions.**

Disassembling the battery or charger, bringing them near flames, allowing them to get wet, or subjecting them to impact (dropping, penetration with nails, or standing on them) may cause an unexpected accident such as the battery igniting or exploding.

- **The device battery should be charged in a well-ventilated space that is free of flammable gases and that is at least twice the size of this device.**

There is a risk of explosion or unexpected accident if the room is filled with flammable gas or if ventilation is insufficient.

- **If damage is found on the exterior of the battery or charger, or if the battery or charger shows any abnormal signs, immediately discontinue use or charging, and contact your distributor or customer support.**

Otherwise, there is a risk of unexpected accident such as electric shock, short circuit or the battery igniting or exploding.

- **Charge using a 100 to 240 V, 50 to 60 Hz power supply outlet. When using an extension cord, use one that is compliant with applicable standards.**

Otherwise, there is a risk of electric shock, short circuit, and fire.



- **Do not disassemble the battery or charger.**

There is a risk of ignition or explosion.

- **Do not touch the battery and charger with wet hands.**

There is a risk of electric shock.

- **Do not touch the battery connector socket or battery connector port directly, allow them to become wet, or bring foreign objects close to them. When inserting the battery, ensure that there are no foreign objects attached.**

Otherwise, there is a risk of injury or electric shock and of damage to this device or its parts.

- **Do not directly touch the battery charging port or charger DC connector, allow them to become wet, or bring foreign objects close to them.**

Otherwise, there is a risk of injury or electric shock and of damage to this device or its parts.

 **WARNING**

- **The battery and charger are both for this device only. Do not charge the battery by using a non-designated charger or charge non-designated batteries with the charger provided with this device.**
Otherwise, there is a risk of unexpected accident such as malfunction or the battery igniting or exploding.
- **Do not touch the charger while the battery is being charged or immediately after the charge is completed.**
There is a risk of burns caused by the charger heating up.
- **Do not apply excessive force to the AC connector cord of the charger.**
Otherwise, there is a risk of electric shock, short circuit, and fire.

 **CAUTION**

- **If this device is not used for a long period, fully charge the battery before storing. Charge the battery at least once a month.**
There is a risk that the battery may get excessively depleted and cannot be charged.
- **Close the battery charging port cap except when charging the battery.**
There is a risk of a short circuit caused by liquid or foreign objects getting inside.
- **Charge at an ambient temperature of 0 to 40°C (32 to 104°F). Charge indoors in a well-ventilated location with little moisture that is not affected by the direct sunlight, rain or condensation.**
The battery may not charge if charged at a temperature outside this range. This may cause battery deterioration or battery malfunction.



- **Do not charge the battery while the brakes are released.**
There is a risk that this device may move, causing an unexpected accident.



- If this device does not start up after five seconds, please check that the battery is charged and properly inserted, and the power is turned ON. If the device will still not start, remove the battery, and then attach the battery again after 10 seconds have elapsed.
- Do not leave the battery for a long time in 0°C (32°F) or lower environments before driving.
- If the battery is not used for a long period, store it in a location with an ambient temperature of 0 to 40°C (32 to 104°F).
- This device sometimes comes to a stop during travel if it goes up steep inclines when the battery temperature is low.
- This device decelerates if it is driven on a downhill slope with the battery close to fully charged. This device decelerates considerably more the lower the battery temperature becomes.
- The scooter will slow down if the battery temperature drops significantly in a low-temperature environment (below 0°C (32°F)). In that case, the driving speed on flat ground is limited to a maximum of 3 km/h (1.9 mph).
- The charger is for indoor use only. Do not charge the battery outdoors.
- Do not charge the battery during lightning storms.
- Under ideal conditions, 4-wheel types can travel a maximum of 17.2 km (10.7 miles) and 3-wheel types can travel a maximum of 18.7 km (11.6 miles). The driving range of this device is affected and varies according to the roads and terrain it is driven on, load, ambient temperature, use of electric supply from the USB port, operating method, and other factors. Pay attention to the battery charge level during use. This device may get stuck while driving if the battery charge level is low.
- Charge the battery after use. Insufficient battery power can be prevented by using a fully charged battery.
- Unplug the DC connector of the charger from the battery charging port after charging.
- If you have any questions about the battery, contact your distributor or customer support.

4.1. Battery and charger

■ Battery

This device uses a lithium-ion battery with a voltage rating of 25.3 V.



When disposing of the battery, contact your distributor or customer support.

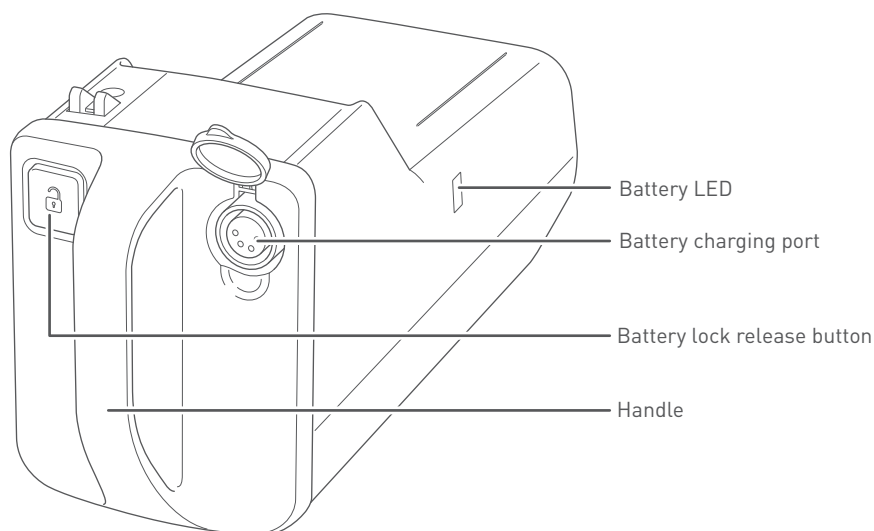

■ Charger

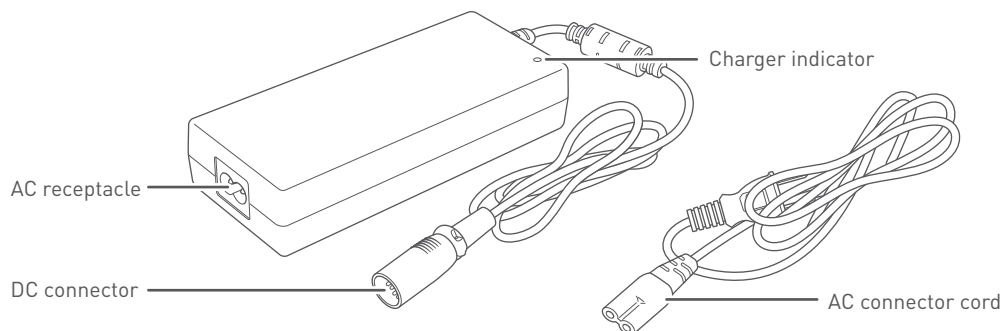

4.2. Charging procedures

Be sure to charge the battery before using this device for the first time or when it has not been used for a long period of time. There are two ways of charging the battery: charging with the battery inserted on this device, or charging with the battery removed from this device. The battery does not require periodic maintenance.

This device cannot be used while the battery is being charged. The approximate battery charging time is 5 hours. When charging is completed, the charger automatically stops battery charging.



- This device cannot be used while the battery is being charged.
- The approximate battery charging time is 5 hours.
- After charging the battery, remove the charger plug from the power supply outlet or extension cord.
- The charger is designed to prevent the battery from overcharging. For this reason, charging is stopped when the battery becomes fully charged.
- As the charger stops charging when the battery becomes fully charged, the battery will gradually discharge and the remaining capacity of the battery will become low if it is left for a long time after charging.
- Do not leave the battery for a long time in 0°C (32°F) or lower environments before driving.
- Do not charge the battery during lightning storms.
- If battery deterioration or malfunction is suspected, such as the driving range becoming considerably shorter than the specification range, even with a fully charged battery, contact your distributor or customer support.

4.2.1. Charging with the battery installed on this device

For safety, this device cannot be used while the battery is being charged.

Charge the battery by the following procedure.

1. Move this device close to the power supply outlet.
2. Turn the device power supply OFF. If the brake is released, pull the brake release levers upwards to apply the brakes.
3. Connect the AC connector cord to the AC receptacle of the charger.

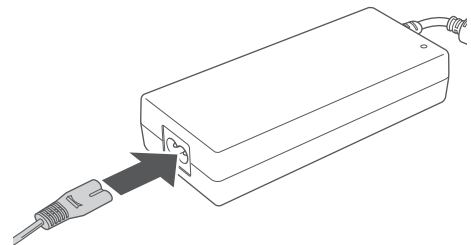

4. Remove the battery charging port cap, and connect the DC connector of the charger to the battery charging port. Connect the DC connector of the charger so that the terminal inside is aligned with the hole of the battery charging port.

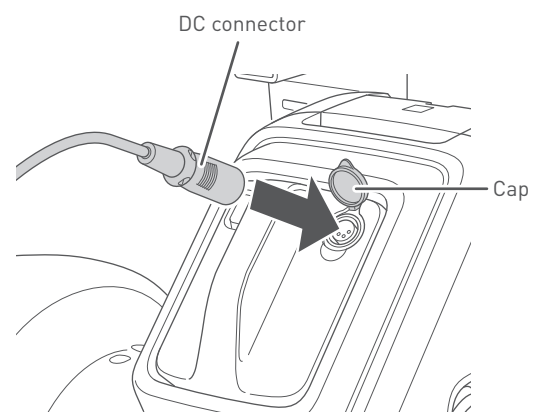

5. Plug the charger into the power supply outlet.

6. The charger indicator begins to flash green, and charging starts.
7. Charging is completed when the charger indicator stops flashing and stays solid green.
8. Remove the charger plug from the power supply outlet.

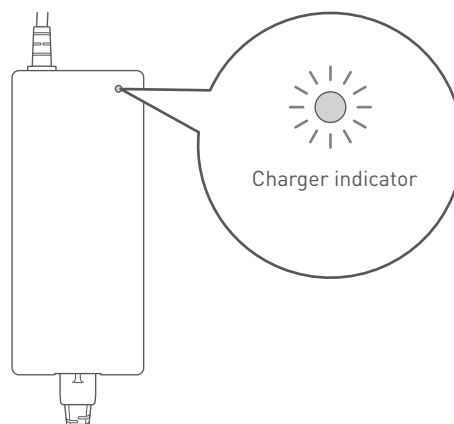

9. Remove the DC connector of the charger from the battery charging port, and close the battery charging port cap.

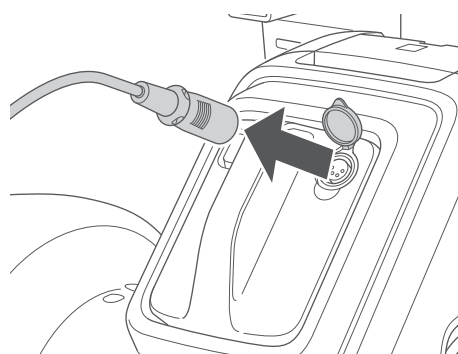

i

- Charge using a 100 to 240 V, 50 to 60 Hz power supply outlet. When using an extension cord, use one that is compliant with applicable standards.
- When the charger indicator is lit yellow at all times, this indicates that the charger plug is connected to the power supply outlet and power is supplied to the charger.
- When the battery is connected to the charger and charging of the battery is started, the charger indicator begins to flash green.
- If the charger indicator does not light or begins to flash yellow, the battery is not properly charged. In this case, disconnect and reconnect again by the following method. If the charger indicator still flashes yellow even after performing the following, a battery or charger malfunction may have occurred. Contact your distributor or customer support.
 1. Disconnect the DC connector of the charger from the battery charging port, and remove the charger plug from the power supply outlet.
 2. Check that the charger indicator light has gone out, and then re-insert the charger plug into the power supply outlet.
 3. Insert the DC connector into the battery charging port.
- If the charger indicator immediately turns green even though the battery is not fully charged, a charger other than the one provided exclusively with this device may have been used. Check the label on the charger.

4.2.2. Charging with the battery removed

1. Turn the device power supply OFF. If the brake is released, pull the brake release levers upwards to apply the brakes.
2. Press the battery lock release button, and remove the battery by holding its handle.

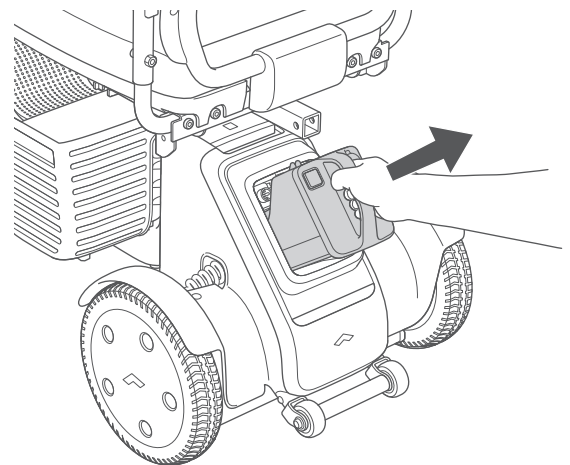
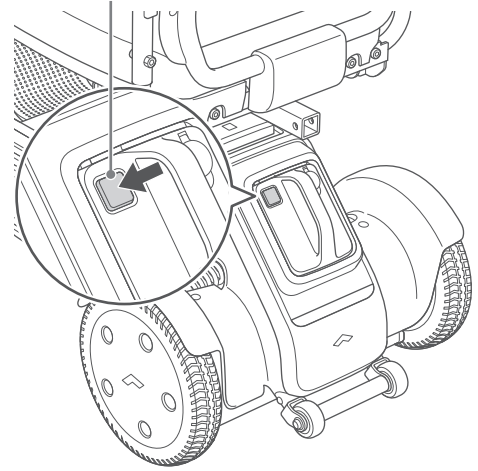
Battery lock release button



3. Connect the AC connector cord to the AC receptacle of the charger.
4. Remove the battery charging port cap, and connect the DC connector of the charger to the battery charging port. Connect the DC connector of the charger so that the terminal inside is aligned with the hole of the battery charging port.

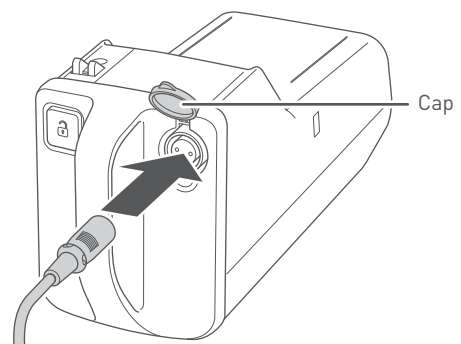

5. Plug the charger into the power supply outlet.
6. The charger indicator begins to flash green, and charging starts.
7. Charging is completed when the charger indicator stops flashing and stays solid green.



You can check the charge level of the battery on the battery LED.

- Full charge: green
- Approx. 30% to less than full charge: orange
- Less than approx. 30%: red
- No charge: purple

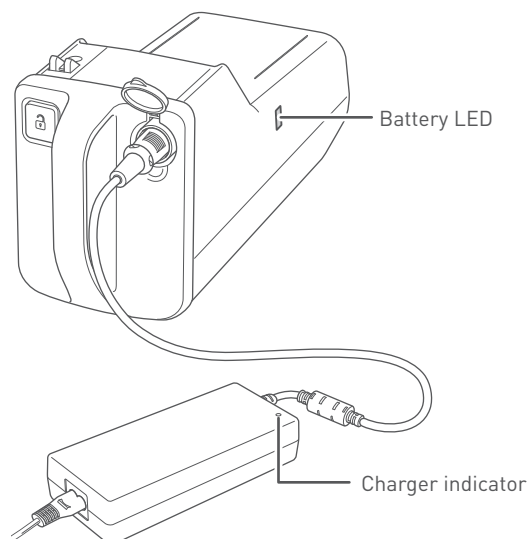

8. Remove the charger plug from the power supply outlet.
9. Remove the DC connector of the charger from the battery, and close the battery charging port cap.

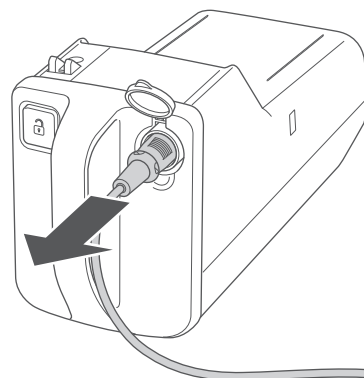

10. Insert the battery.

For the installation procedure, refer to "3.3.9. Installing the battery" on page 37.

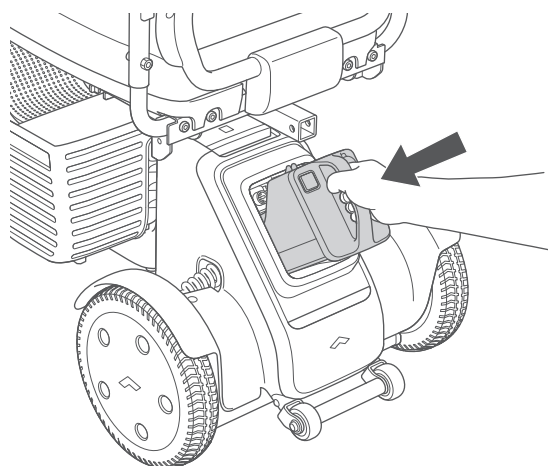



- Charge using a 100 to 240 V, 50 to 60 Hz power supply outlet. When using an extension cord, use one that is compliant with applicable standards.
- When the charger indicator is lit yellow at all times, this indicates that the charger plug is connected to the power supply outlet and power is supplied to the charger.
- When the battery is connected to the charger and charging of the battery is started, the charger indicator begins to flash green.
- If the charger indicator begins to flash yellow, the battery is not properly charged. In this case, disconnect and reconnect again by the following method. If the charger indicator still flashes yellow even after performing the following, a battery or charger malfunction may have occurred. Contact your distributor or customer support.
 1. Disconnect the DC connector of the charger from the battery charging port, and remove the charger plug from the power supply outlet.
 2. Check that the charger indicator light has gone out, and then re-insert the charger plug into the power supply outlet.
 3. Insert the DC connector into the battery charging port.
- If the charger indicator immediately turns green even though the battery is not fully charged, a charger other than the one provided exclusively with this device may have been used. Check the label on the charger.

4.2.3. Charger indicator displays

The charger indicator illuminates lights according to the battery states as shown below.

Charger Indicator Color	Charger Indicator State	Charger Status
Yellow	Flashing	Charging error
Yellow	Lit	The charger plug is connected to the power supply outlet and power is supplied to the charger.
Green	Flashing	Battery charging in progress
Green	Lit	Battery charging completed



- If the charger indicator does not light or begins to flash yellow, the battery is not properly charged. In this case, disconnect and reconnect again by the following method. If the charger indicator still flashes yellow even after performing the following, a battery or charger malfunction may have occurred. Contact your distributor or customer support.
 1. Disconnect the DC connector of the charger from the battery charging port, and remove the charger plug from the power supply outlet.
 2. Check that the charger indicator light has gone out, and then re-insert the charger plug into the power supply outlet.
 3. Insert the DC connector into the battery charging port.
- If the charger indicator immediately turns green even though the battery is not fully charged, a charger other than the one provided exclusively with this device may have been used. Check the label on the charger.

5. Operating procedures

This section explains the procedures for getting in and operating this device.

WARNING



- Do not apply an excessive load to the controller unit, such as leaning or sitting on it. Do not operate the throttle control lever or buttons with excessive force or operate them with a sharp object.

These parts might become damaged and render them inoperable.

CAUTION



- If this device is not used for a long period, fully charge the battery before storing. Charge the battery at least once a month.

There is a risk that the battery may get excessively depleted and cannot be charged.



- The waterproof performance of this device with the battery attached is IPX5. However, to prevent unexpected malfunction, avoid use in heavy rain.
- When using this device for the first time, it is recommended that you use it in an environment with an assistant nearby.

5.1. Inspection before getting in this device

WARNING



- **Inspect the following every time before getting in this device.**

Use of this device when it is malfunctioning can potentially cause an injury or unexpected accident. If you encounter any problems that you are unable to resolve by yourself, contact your distributor or customer support.

■ Inspection items

1. Inspection with the power supply turned OFF

■ Assembly and adjustment

- Check that all parts are not loose and are correctly assembled.
- Check that no parts are broken or have fallen off.
- Check that the frame release lever of the drive base and the tiller adjustment lever on the right of the tiller unit are locked correctly.
- Where adjustments can be made, adjust this device to an easy-to-use position and angle to meet the user's seating needs.

■ Function

- Check that the brakes can be released and this device can be pushed manually. Also, check, when the brakes are locked, that this device does not move when pushed.

■ Wheels

- Check the tire treads and ensure they are not worn down by more than 0.5 mm (1/64 inches). Check that there are no foreign objects caught in the tire tread.
- Check that the tires are not cracked or deformed.
- Check that the wheels are not wobbly.

2. Inspection with the power supply turned ON

- Check that the battery charge level indicator, speed select indicator, and other indicators are displayed normally on the display of the controller unit.
- Check that the front light and rear light turn ON.
- Check that the battery charge level is sufficient.
- Check that the tiller unit is functional.
- Check that the throttle control lever is not wobbly.
- Check that the alarm tone is audible when the horn button is pressed.
- Check that D (forward) and R (reverse) on the throttle control lever function.
- Check that the wheels are not making unusual noises when they turn.



- Use a fully charged battery.
- Under ideal conditions, 4-wheel types can travel a maximum of 17.2 km (10.7 miles) and 3-wheel types can travel a maximum of 18.7 km (11.6 miles). The driving range of this device is affected and varies according to the roads and terrain it is driven on, load, ambient temperature, use of electric supply from the USB port, operating method, and other factors. Pay attention to the battery charge level during use. This device may get stuck while driving if the battery charge level is low.

5.2. Getting on this device

Be sure to read and fully understand the descriptions in this manual before use.

Before going out onto public roads for the first time, be sure to practice driving this device. If you want to practice driving, do so in an open space with good visibility. When getting in this device, pay attention to the following.

WARNING



- **Before getting on and off this device, apply the brakes on a flat and level surface.**
Otherwise, there is a risk of unexpected accident.
- **Before getting on and off this device, turn the device power supply OFF.**
There is a risk of unexpected movement of this device caused by accidental contact with the controller unit.
- **Check that the brakes are locked before getting in this device. Do not leave this device while the brakes are released.**
If the brakes are released, there is a risk that this device may suddenly start moving.
- **The maximum load-bearing capacity for this device is 147 kg (325 lbs.) including both the occupant and any luggage. Use this device without subjecting it to a load higher than this capacity.**
There is a risk of this device being damaged.
- **If your body is not stable when seated in this device, use the lap belt (sold separately).**
This device may tip over or fall, and there is a risk of unexpected accident. If you have any questions about the lap belt, contact your distributor or customer support.



- **Do not apply an excessive load to the controller unit, such as leaning or sitting on it. Do not operate the throttle control lever or buttons with excessive force or operate them with a sharp object.**
These parts might become damaged and render them inoperable.
- **Do not hang walking sticks, umbrellas, bags, baskets, or other objects on the tiller handle, throttle control lever and armrests.**
Otherwise, there is a risk of damage to parts or unexpected accident.
- **Do not jump onto this device or place all your weight on the edge of the footrest.**
This device may tip over, and there is a risk of unexpected accident.
- **Prevent clothing, scarves or other objects from touching the wheels while driving.**
If clothing, scarves or other objects get entangled in the wheels, there is the risk of injury and unexpected accident.

CAUTION



- **The maximum speed of this device is 8 km/h (5 mph) or 6 km/h (3.7 mph) depending on countries/areas. Check the speed of this device in a safe place. Set the maximum speed using the speed select button.**
This device may tip over, and there is a risk of unexpected accident.



- Under ideal conditions, 4-wheel types can travel a maximum of 17.2 km (10.7 miles) and 3-wheel types can travel a maximum of 18.7 km (11.6 miles). The driving range of this device is affected and varies according to the roads and terrain it is driven on, load, ambient temperature, use of electric supply from the USB port, operating method, and other factors. Pay attention to the battery charge level during use. This device may get stuck while driving if the battery charge level is low.
- This device sometimes comes to a stop during travel if it goes up steep inclines when the battery temperature is low.
- This device decelerates if it is driven on a downhill slope with the battery close to fully charged. This device decelerates considerably more the lower the battery temperature becomes.
- For errors that occur during use, check “9. Troubleshooting” on page 92.

5.2.1. Rotating the seat and getting in this device

1. Hold the seat frame while pulling up the seat rotation lever under the seat, and rotate the seat.

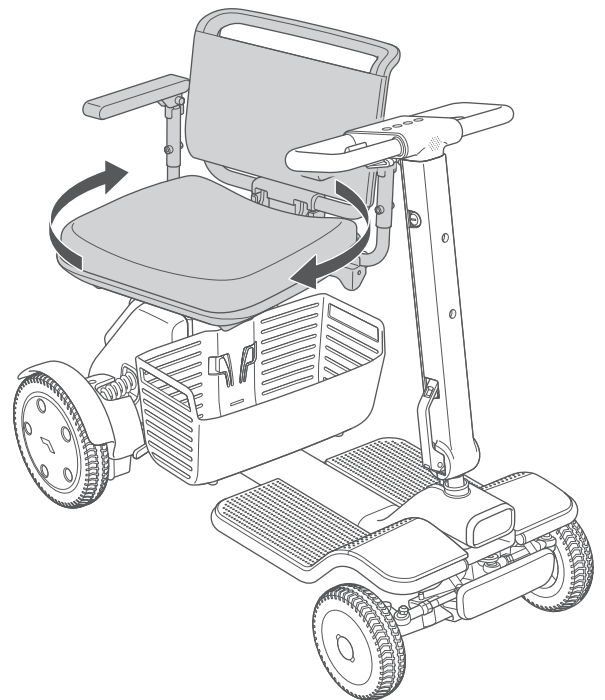
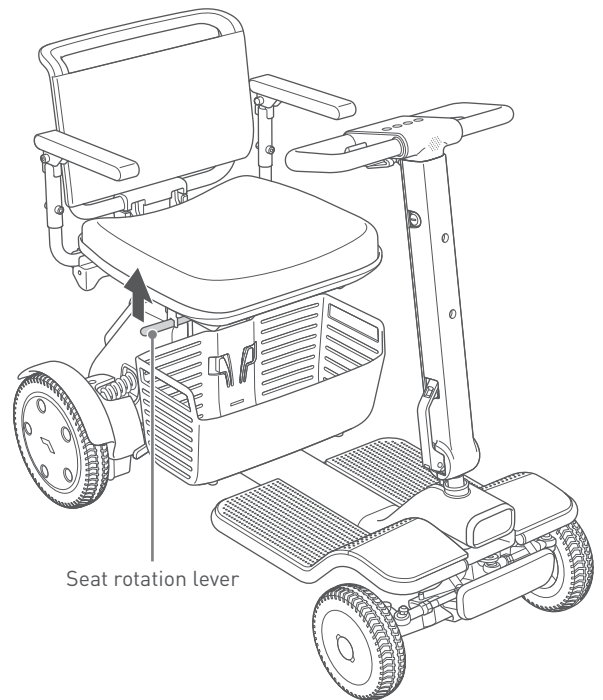

2. Sit on the seat, and rotate the seat again while pulling up the seat rotation lever under the seat.
3. When the seat comes to the position where you are facing towards the front, release the seat rotation lever, and lock rotation of the seat.



- Do not rotate the seat by holding just the seat rotation lever or apply excessive force to the lever. There is a risk of the seat rotation lever being damaged.
- Be sure to lock rotation of the seat at the position where you are facing towards the front. If you are not facing towards the front, there is the risk that correct operation will not be possible while driving.

5.3. Turning the power supply ON

1. Check that the brake release levers are at the upward position, and that the brake is applied. If the brake is released, pull the brake release levers upwards to apply the brakes.

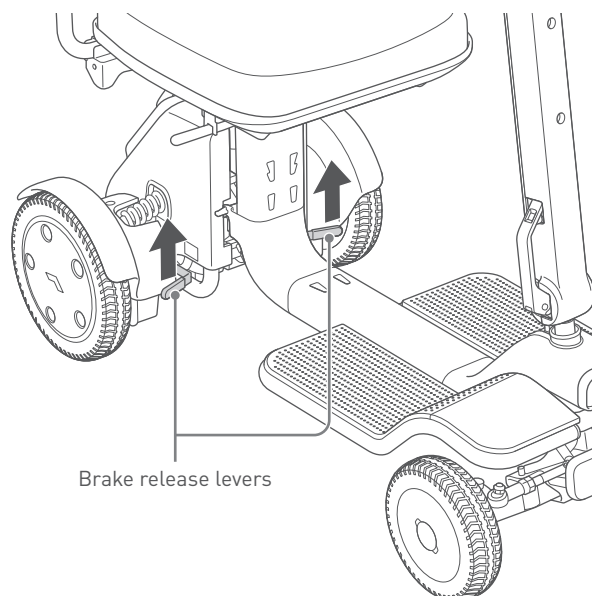

2. The power supply of this device can be turned ON by one of the following methods.
When the power supply is turned ON, the WHILL logo is displayed on the controller unit and the display switches to the battery charge level indicator.

■ Mechanical key

Insert the mechanical key into the key cylinder on the right side of the tiller unit, and turn clockwise.



■ Smartphone app

Connect the smartphone app to this device, and slide the white circle power supply indicator on the screen of the smartphone app to the right.

For the smartphone app installation procedure, refer to "7. About the smartphone app" on page 86.

■ Smart key (sold separately)

Press the smart key unlock button.



- For safety, the power supply will not turn ON with the throttle control levers operated. If an error code is displayed on the controller unit, turn the power supply OFF, and then turn the power supply ON again without operating the throttle control lever.
- For safety, the power supply will not turn ON while the brakes are released. If an error code is displayed on the controller unit, turn the power supply OFF, pull the brake release levers upwards to apply the brakes, and then turn the power supply ON.
- If this device does not start up after five seconds, please check that the battery is charged and properly inserted, and the power is turned ON. If the device will still not start, remove the battery, and then attach the battery again after 10 seconds have elapsed.

5.3.1. Checking the battery charge level

5

Check the battery charge level displayed on the controller unit. The battery charge level is displayed as a numerical value from 0 to 100%, changing in increments of 1%.

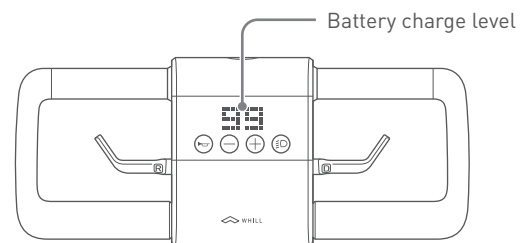

- The battery charge level may decrease rapidly or unexpectedly for various reasons such as the environment or battery conditions due to the characteristics of the lithium ion battery.
- Regardless of the charge level, charge the battery after use, and use a fully charged battery.

■ Travel distance

- When the front light is lit or electric supply from the USB port is in use, the travel distance of this device is shorter.
- During winter, because of the characteristics of the battery, the travel distance sometimes is shorter than that during summer.
- The travel distance becomes shorter as the battery deteriorates

5.3.2. Setting the maximum speed

⚠ CAUTION



- Operate the speed select button when this device is stationary. If it is absolutely necessary to operate the speed select button during travel, operate it while paying attention to the road ahead with the tiller handle firmly gripped to prevent driving from being obstructed. There is a risk that operating the speed select button during travel will result in the user not keeping his or her eyes on the road, and cause an unexpected accident.

Set the maximum speed using the speed select buttons on the controller unit. The speed can be adjusted up to the maximum speed in 4 stages from 1 (slow) to 4 (fast) by operating the speed select buttons.

+ button: Increases the speed

- button: Decreases the speed



- The maximum speed becomes the speed when the throttle control lever (D) on the right side is pulled towards you as far as possible.
- The speed can be adjusted depending on how far the throttle control lever is pulled.
- When moving backwards and rotating, the maximum speed is limited to 2 km/h (1.2 mph) even when the maximum speed is set to 4 (fast).

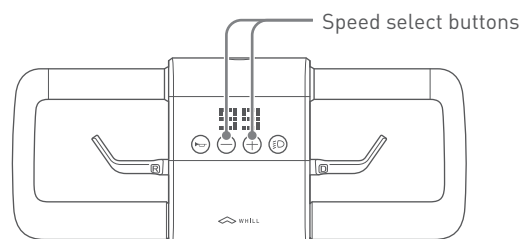

5

5.3.3. Using the horn button

The alarm tone can be sounded by pressing the horn button on the controller unit. Use this button, for example, to notify those around you of your presence.

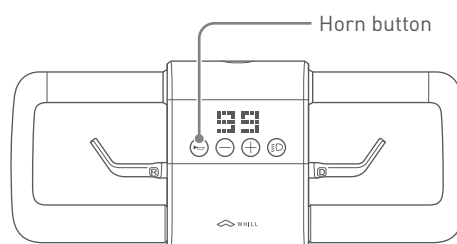

5.3.4. Using the front light button

The front light can be switched OFF and ON by pressing the front light button on the controller unit.



The front light turns on simultaneously with the device power supply turned ON.

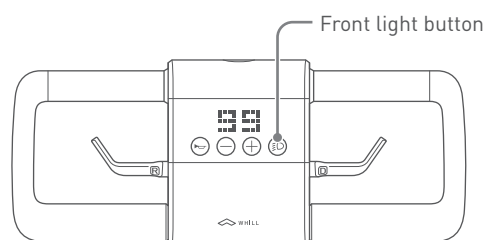

5.4. Driving

This device is intended for use in pedestrian areas. When driving, please use pedestrian paths, observing the traffic law.

WARNING



- **Make sure that the battery is properly locked before driving.**
This device may stop while driving due to problems between the connection of this device and battery.
- **Check that the frame release lever of the drive base is locked correctly.**
There is a risk of unexpected accident by the frame being released suddenly while driving.
- **Check that the tiller adjustment lever on the right of the tiller unit is locked correctly.**
There is a risk of the tiller unit suddenly becoming loosely secured while driving and tipping over, and causing an unexpected accident.
- **When driving, fully check the surroundings and road conditions. Drive carefully at low speed particularly when driving in locations crowded with people, close to walls or other locations where there are obstacles nearby, and in narrow places or on uneven surfaces or slopes. Do not drive off or stop suddenly.**
When driving on wet inclines, in particular, there is a risk that this device may lose stability, and cause an unexpected accident.
- **When approaching curbs, steps, slopes, and similar obstacles, approach at a right angle and drive over them carefully at low speed. On 4-wheel types, make sure you are not driving with only one front wheel on curbs, steps, slopes, and similar obstacles. On 3-wheel types, make sure you are not driving with the anti-tip rollers (front) on curbs, steps, slopes, and similar obstacles.**
There is a risk of tipping over or damage to parts.
- **When driving, the user must take care to prevent him- or herself or others in the immediate surroundings from touching the wheels.**
There is a risk of injury.
- **On downhill slopes, slow down sufficiently and drive carefully.**
This device may tip over or fall, and there is a risk of unexpected accident.
- **When stopping on a downhill slope, return the throttle control lever promptly to its original position, and make sure that this device stops with an ample amount of extra space around it.**
The stopping distance is longer when on a downhill slope. There is a risk that you may be unable to stop at the expected position, causing an unexpected accident.
- **Release the brakes only when necessary. Before releasing the brakes, be sure to move to a flat and safe surface, and then turn the device power supply OFF. After moving this device manually, pull the brake release levers upwards to apply the brakes.**
There is a risk of unexpected accident because this device will move freely when the brakes are released.



- **While driving, maintain consistent speed and avoid sudden turning and stops.**
Otherwise, there is a risk of injury or unexpected accident.
- **Prevent your feet from extending outside the footrest while driving.**
Otherwise, there is a risk of injury or unexpected accident.

 **WARNING**

- **Do not hang walking sticks, umbrellas, bags, baskets, or other objects on the tiller handle, throttle control lever and armrests.**
Otherwise, there is a risk of damage to parts or unexpected accident.
- **Do not apply an excessive load to the controller unit, such as leaning or sitting on it. Do not operate the throttle control lever or buttons with excessive force or operate them with a sharp object.**
These parts might become damaged and render them inoperable.
- **While riding this device, do not crouch down, lean outside, or shake your body.**
This device may tip over or fall, and there is a risk of unexpected accident.
- **Do not drive while holding something in your hand or with something placed on your lap.**
There is a risk of incorrect operation or tipping over.
- **Do not drive the device in the following areas or under the following conditions.**
This device may tip over, and there is a risk of unexpected accident.
 - Escalators or stairs
 - Steps of 5 cm (2 in.) or more in height
 - Slopes with a gradient of 10° or more
 - Soft surfaces such as sand or mud
 - Puddles
 - Snowy or frozen paths
 - Diagonal driving on slopes that exceed 10° left and right
 - Gaps of 10 cm (3.9 in.) or more in width
 - Sudden turning or driving in a zigzag
 - Driving in reverse or medium- to high-speed driving on downhill slopes
 - Bad weather such as rain, fog or strong wind
- **When you do not feel well, are under the influence of alcohol or are taking medication, do not drive this device.**
This may dull your judgment, and cause the risk of serious accident.
- **Do not extend arms, legs, or baggage outside of this device.**
There is a risk of injury caused by collision while driving.
- **While driving, do not operate a mobile phone, smartphone or other devices. Before operating these devices, stop the scooter at a safe place, and turn the scooter power supply OFF. Also, do not drive while wearing earphones or headphones that make it difficult to hear surrounding sounds.**
Otherwise, there is a risk of accident.
- **Do not tow using this device.**
There is a risk of tipping over.
- **Prevent clothing, scarves or other objects from touching the wheels while driving.**
If clothing, scarves or other objects get entangled in the wheels, there is the risk of injury and unexpected accident.

⚠ CAUTION



- **Avoid crossing level crossings as there is the risk of getting stuck in the middle of the crossing. When it is absolutely necessary to cross a level crossing, pay attention to the following. Also pay attention to the following when crossing streetcar tracks.**

Otherwise, there is a risk of unexpected accident.

- Before crossing level crossings and railway tracks, check that the battery charge level is sufficient.
- Be accompanied by an assistant.
- In the case of wide level crossings and railway tracks that will take time to cross, make a detour.
- When the level crossing alarm starts to sound or the level crossing barrier starts to drop, never move inside the level crossing.
- Cross level crossings at right angles to the railway tracks to prevent this device from getting caught in the gaps of the tracks.
- Do not rotate on level crossings and railway tracks.

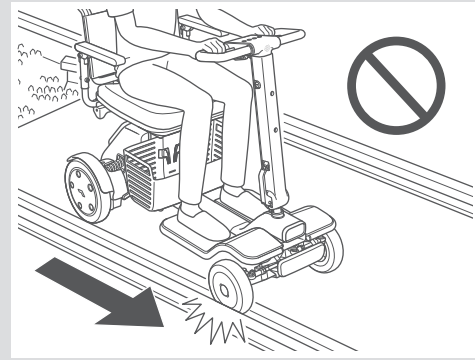
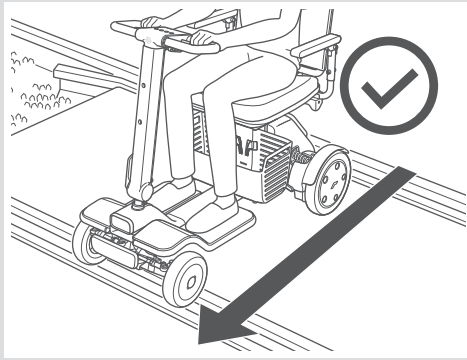

- **Check the battery charge level displayed on the controller unit. If the battery charge level is low, charge the battery immediately.**
This device may get stuck while driving if the battery charge level is low.
- **Drive on sidewalks or paths for pedestrians, and use pedestrian crossings, observing the traffic law.**
This device is not designed for use on roads for automobiles. Otherwise, there is a risk of accident.



- **Do not operate the brake release levers with your feet.**
The brake release levers may become deformed, broken, and unusable.

■ Procedure to start driving

1. Check that the brake release levers are at the upward position, and that the brake is applied. If the brake is released, pull the brake release levers upwards to apply the brakes.
2. Sit in the seat correctly, and check your surroundings in front and behind and to the left and right.
3. Turn the power supply ON by one of the following methods.
 - Mechanical key
 - Smartphone app
 - Smart key (sold separately)
4. Set the maximum speed using the speed select buttons on the controller unit.
5. Firmly grip the tiller handle with both hands.
6. Gently pull the throttle control lever (D) on the right side towards you to drive off. The speed can be adjusted within the range up to the preset maximum speed depending on how far the throttle control lever is pulled. When the throttle control lever is returned to its original position, this device decelerates and comes to a stop.

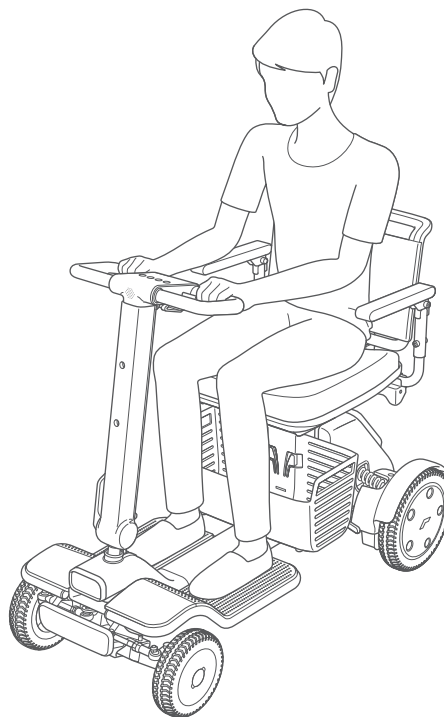

i

- Before going out onto public roads for the first time, be sure to practice driving this device. If you want to practice driving, do so in an open space with good visibility.
- This device sometimes decelerates on slopes depending on the operating environment and load.
- The front tires of the 4-wheel type are oriented slightly outwards. When driving over a bump, ensure that at least one of the wheels is positioned perpendicular to the bump to help the device get over a higher bump.
- If you use this device indoors, there is a risk that flooring may be damaged or become dirty.

5.4.1. Moving forwards and backwards

To move forwards, pull the throttle control lever (D) on the right side towards you while holding the tiller handle, and, to move backwards, pull the throttle control lever (R) on the left side towards you while holding the tiller handle. The more you pull, the faster the drive speed becomes up to the preset speed set as the maximum speed. The maximum speed when moving forwards is 8 km/h (5 mph) or 6 km/h (3.7 mph) depending on countries/areas, and the maximum speed when moving backwards is 3.2 km/h (2 mph).

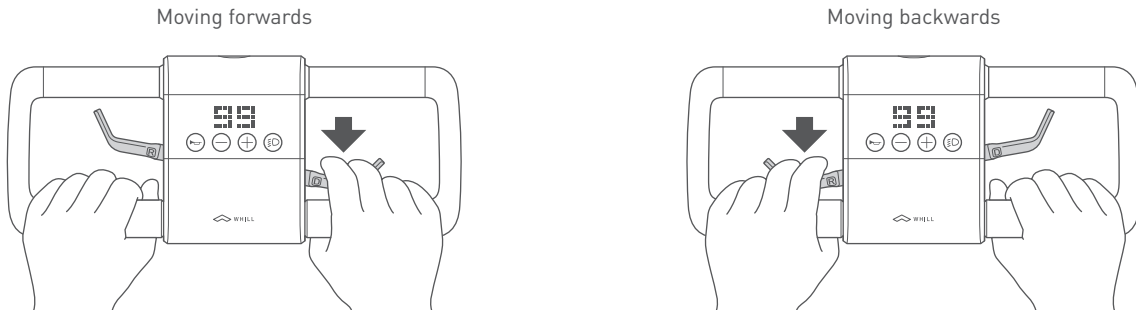

5.4.2. Turning corners

5

To move to the left, turn the tiller handle to the left, and, to move to the right, turn the tiller handle to the right. When operating the tiller handle, hold the tiller handle with both hands. When changing directions, pay attention to the difference in the turning radius.

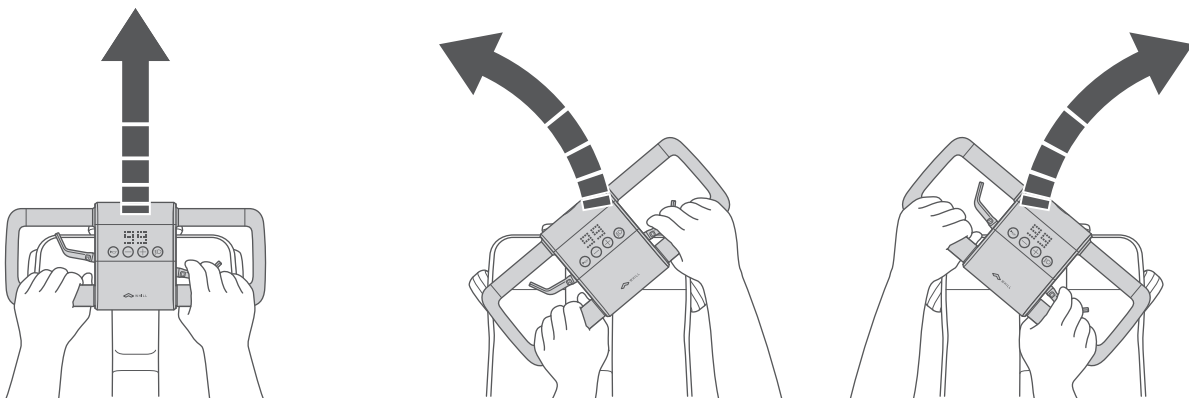

5.4.3. Turning

To turn on the spot, return the throttle control lever to its original position, and then turn the tiller handle as far as possible in the direction you want to turn. Also, to move straight ahead after turning, return the throttle control lever in the same way to its original position, and then turn the tiller handle to face forward.

- The maximum speed when turning is 2.5 km/h (1.6 mph).
- The safety interlock sometimes activates when turning, as a large load is temporarily placed on the motor during turning. If the device has stopped moving during a turn, turn the power supply ON again.

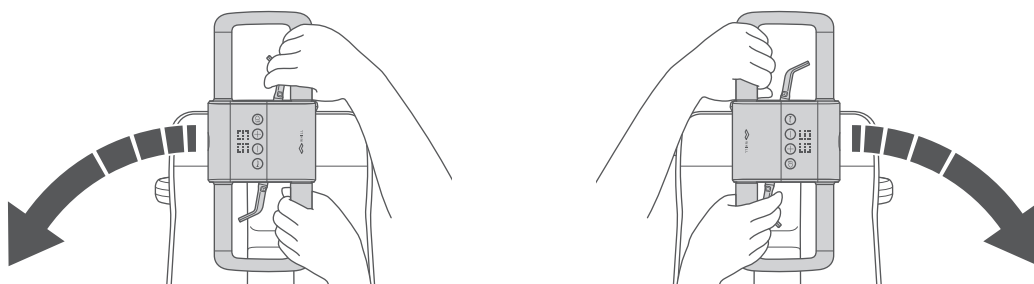

5.4.4. Stopping

When the throttle control lever is returned to its original position, this device decelerates and comes to a stop.

5.4.5. Adjusting the speed

The speed can be adjusted up to the maximum speed in 4 stages from 1 (slow) to 4 (fast) by operating the speed select buttons. While driving, the speed can be adjusted within the range up to the maximum speed depending on how far the throttle control lever is pulled. When changing the maximum speed while driving, be sure to do so with one hand gripping the tiller handle. To prevent accidents, pay attention to the immediate surroundings when changing the speed.

5.4.6. Driving under different road conditions

This device can maintain stability under a wide range of road conditions. However, it cannot be driven under the following conditions.

- Steps of 5 cm (2 in.) or more in height

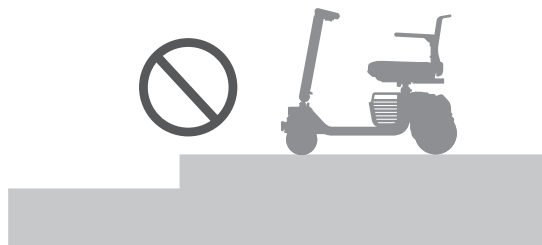
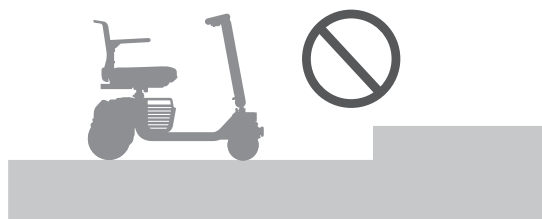

- Slopes with a gradient of 10° or more

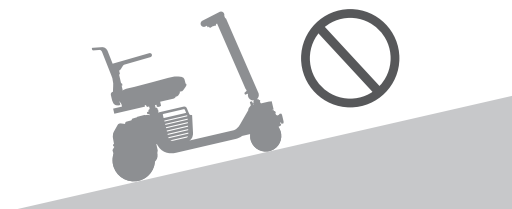

- Diagonal driving on slopes exceeding 10°

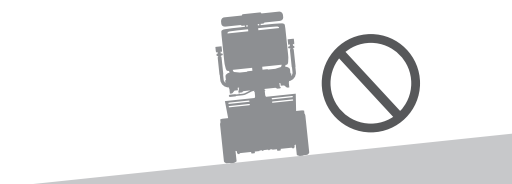

- Gaps of 10 cm (3.9 in.) or more in width

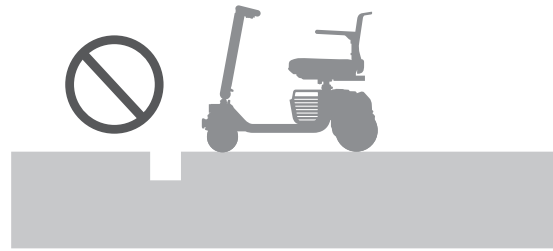
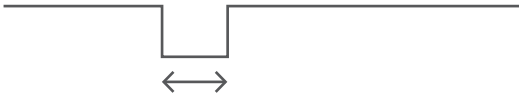

- Soft surfaces such as sand, mud, snowy or frozen paths.

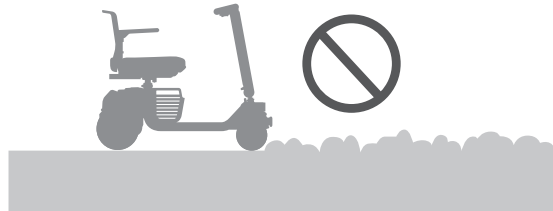

5

5.5. Turning the power supply OFF

1. The power supply of this device can be turned OFF by one of the following methods.

■ Mechanical key

Turn the mechanical key counterclockwise. When moving away from this device, be sure to remove the mechanical key from the key cylinder to prevent other people from driving this device and store the key.

■ Smartphone app

Connect the smartphone app to this device, and slide the white circle power supply indicator on the screen of the smartphone app to the right. For the smartphone app installation procedure, refer to “7. About the smartphone app” on page 86.

■ Smart key (sold separately)

Press the smart key lock button.

5.6. Releasing the brakes

This device can be moved manually by pushing down the brake release levers located below the seat. This device cannot be operated by the motor while the brakes are released.

⚠ WARNING



- Release the brakes only when necessary. Before releasing the brakes, be sure to move to a flat and safe surface, and then turn the device power supply OFF. After moving this device manually, pull the brake release levers upwards to apply the brakes. There is a risk of unexpected accident because this device will move freely when the brakes are released.



- Do not move this device manually on slopes while the brakes are released. There is a risk of unexpected accident because the brakes do not work.

⚠ CAUTION



- When moving this device by hand after releasing the brakes, push it slowly while paying attention to the condition of the road. When the brakes are released, this device will move freely. Pushing it forcefully may cause it to move in an unexpected direction. Also, when this device is pushed at the maximum speed of 8 km/h (5 mph) or higher, a strong brake will be applied for protection, and there is a risk that unexpected accidents may occur.



- Do not operate the brake release levers with your feet. The brake release levers may become deformed, broken, and unusable.

5

5.6.1. Brake release procedure

1. Check that the device power supply is OFF.
2. Push the brake release levers downwards.

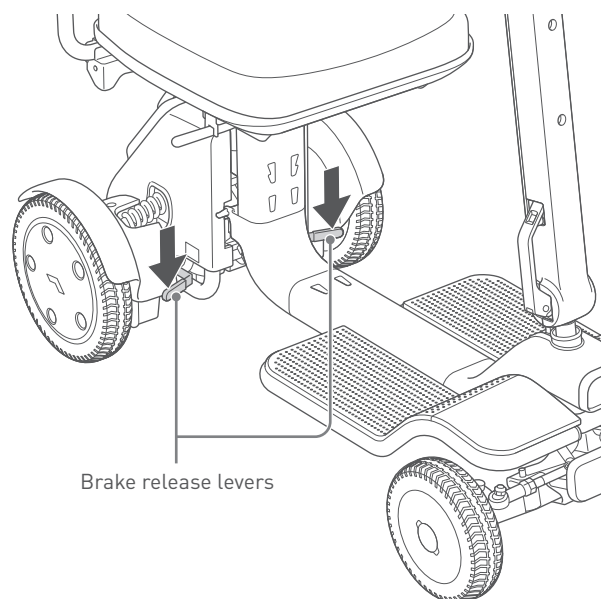

3. Hold the tiller handle, and move this device by pushing manually.

5.7. Carrying items

Do not hang walking sticks, umbrellas, bags, baskets, or other objects on the tiller handle, throttle control lever and armrests. When carrying items, be sure to use the basket and only authentic or designated accessories.

CAUTION



● **Pay attention to the following when using the basket.**

Otherwise, there is a risk of unexpected accident.

- Do not load items in the basket in excess of its maximum storage load.
- Load items in the basket so that they do not exceed the height of the sides of the basket.
- Before placing or removing any items from the basket, turn the device power supply OFF, and verify the safety of your surroundings.



The maximum storage basket load is 6 kg (13.2 lbs.). If a load heavier than the maximum storage basket load is placed in it, the basket may be damaged.

6. Storage and transport methods

6.1. Storage

Pay attention to the following when storing this device.

- Do not store it near flame or flammable gas.
- Store this device in a location with an ambient temperature of -15 to 40°C (5 to 104°F).
- Store the battery and charger in a location with an ambient temperature of 0 to 40°C (32 to 104°F).
- Store them indoors or in an environment such as under a roof where they will not be splashed by rain or the like.
During storage, covering them is recommended.

WARNING



- Do not store the battery in locations subject to the direct sunlight or in a location with an ambient temperature of 40°C (104°F) or higher.
Otherwise, there is a risk of unexpected accident such as the battery igniting or exploding.

CAUTION



- If this device is not used for a long period, ensure the battery is fully charged before storing.
Charge the battery at least once a month.
There is a risk that the battery may get excessively depleted and cannot be charged.



- Do not store this device for a long period of time in a location with heavy amounts of dust or sand, near the sea, or in a hot spring area.
Otherwise, there is a risk of foreign objects getting inside this device and corroding this device or its parts.
- Do not store this device with a heavy object placed on it for a long period.
There is a risk of device malfunction.
- Do not place the battery or device in a location that is inclined or in a vibration-prone area.
There is a risk of damage or malfunction of the battery or device.
- Do not place the battery on a high shelf, or in other similar places.
There is a risk of injury to the user and damage to parts as a result of falling.
- When removing the battery and storing this device, take sufficient care to prevent foreign objects or water from coming into contact with the connecting parts of the battery and device.
There is a risk of device malfunction due to short circuiting of the battery or device.
- Do not store this device outdoors in a location exposed to direct sunlight or rain.
There is a risk that rain may cause a short circuit on the battery or device, and that direct sunlight may cause deformation or deterioration of this device. Store them indoors or in another location under a roof. During storage, covering them is recommended.

■ When storing for a long period

- At least once a month, charge the battery and check that this device operates correctly.
- Before using this device again after a prolonged period of disuse, charge the battery, and be sure to check that this device operates correctly and safely.

- Store this device in a location with an ambient temperature of -15 to 40°C (5 to 104°F).
- Store the battery and charger in a location with an ambient temperature of 0 to 40°C (32 to 104°F).
- When this device has not been used for a prolonged period, there is the risk that the part of the tires that are contacting the ground will be deformed. Rotate the tires at least once a month to ensure that different areas of the tire are contacting the ground.

6.2. Transporting this device

Pay attention to the following when transporting this device.

- When transporting this device disassembled, refer to “3.5. Disassembly procedures” on page 47.
- When lifting this device or disassembled parts, be sure to hold the parts specified in this manual.
- When securing this device to a carrier or the like, be sure to secure it to the parts specified in this manual.
- For air transport, check beforehand with the airline regarding whether or not powered scooters can be transported, methods of transportation or other details.
- The device has not been tested against the limits specified in the Technical Specification for Interoperability relating to Accessibility for Persons with Reduced Mobility (PRM-TSI).

WARNING



- **When transporting the drive base, align the tiller unit rotation stopper with the C-shaped protrusion on the tiller unit so that the drive base can be transported with rotation of the tiller unit secured.**

The tiller unit might rotate, and there is a risk of hand injury if a hand gets caught in the front wheel.



- **Do not lift up this device or load it onto a vehicle when there is a person or object on it.**

There is a risk of injury to the user and damage to parts as a result of falling.

- **Do not use this device as a seat in an automobile or other vehicle.**

Otherwise, there is a risk of damage to parts or unexpected accident. The symbol on the right indicates that this device is not intended to be used as a seat in a motor vehicle.



- **Do not touch the drive base connector socket or main body connector port directly, allow them to become wet, or bring foreign objects close to them. When assembling, ensure that there are no foreign objects attached.**

Otherwise, there is a risk of injury or electric shock and of damage to this device or its parts.

- **Do not touch the battery connector socket or battery connector port directly, allow them to become wet, or bring foreign objects close to them. When inserting the battery, ensure that there are no foreign objects attached.**

Otherwise, there is a risk of injury or electric shock and of damage to this device or its parts.

⚠ CAUTION



- When using a lift for transporting this device, be sure to apply the brake and fasten this device securely.

There is a risk of this device falling and being damaged.

- After loading this device onto a vehicle, secure parts specified with rope or the like with the brake applied.

There is a risk of damage to parts and tipping over.



- Do not transport this device with a heavy object placed on it.

There is a risk of device malfunction.

- Do not lift up this device directly by a crane.

There is a risk of this device falling and being damaged.

- Do not tow using this device.

There is a risk of damage to parts and tipping over.

6.2.1. How to hold each part

■ Seat

1. Transport this by holding both sides of the seat base.

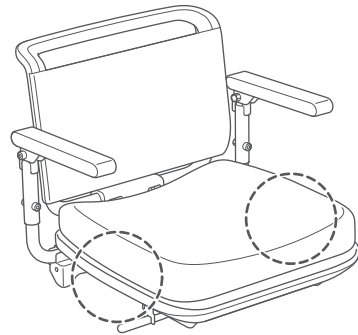

■ Drive base

1. Transport this by holding the footrest frames.



Rotation of the tiller unit is secured in place by aligning the tiller unit rotation stopper with the C-shaped protrusion on the tiller unit.

4-Wheel type

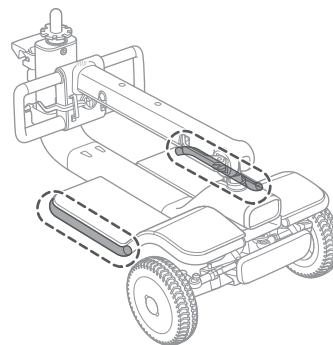

3-Wheel type

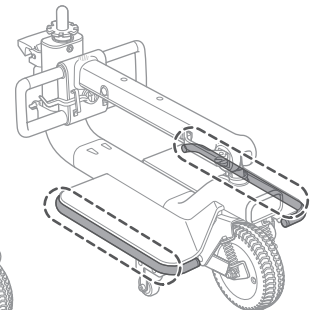

■ Main body

1. Transport this by holding frame tube B and the bar between the anti-tip rollers (rear).

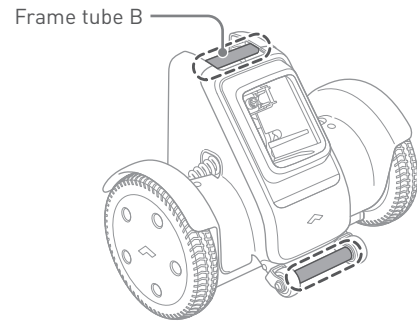

■ Device (not disassembled)

1. Remove the battery. For the removal procedure, refer to “3.5.1. Removing the battery” on page 48.
2. Two or more people must transport this device by holding the footrest frames on both sides and the bar between the anti-tip rollers (rear).

Do not lift up this device when there is a person on it.

4-Wheel type

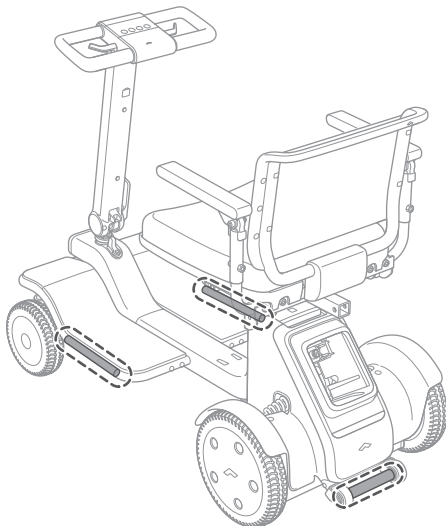

3-Wheel type

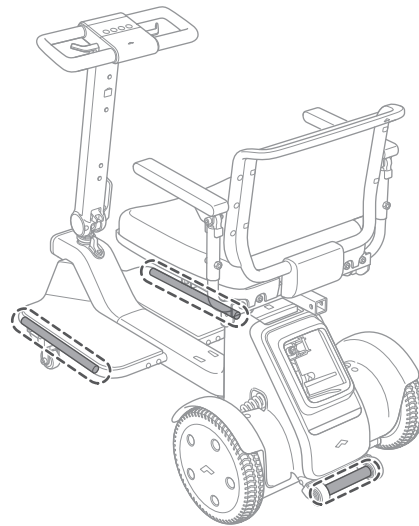

6.2.2. Loading/unloading this device onto/from a vehicle

When loading this device onto a vehicle without it being disassembled, use a ramp or the like. Operate this device in the forward direction using the handles, and take sufficient care to prevent this device from falling off the ramp. Do not load or unload this device when there is a person on it.

■ Securing this device

Secure the four specified parts (two locations on drive base, two locations on main body) of the frame. Make sure that the securing destinations are positioned lower than the height of the frame to prevent this device from being damaged by ropes or the like.

4-Wheel type

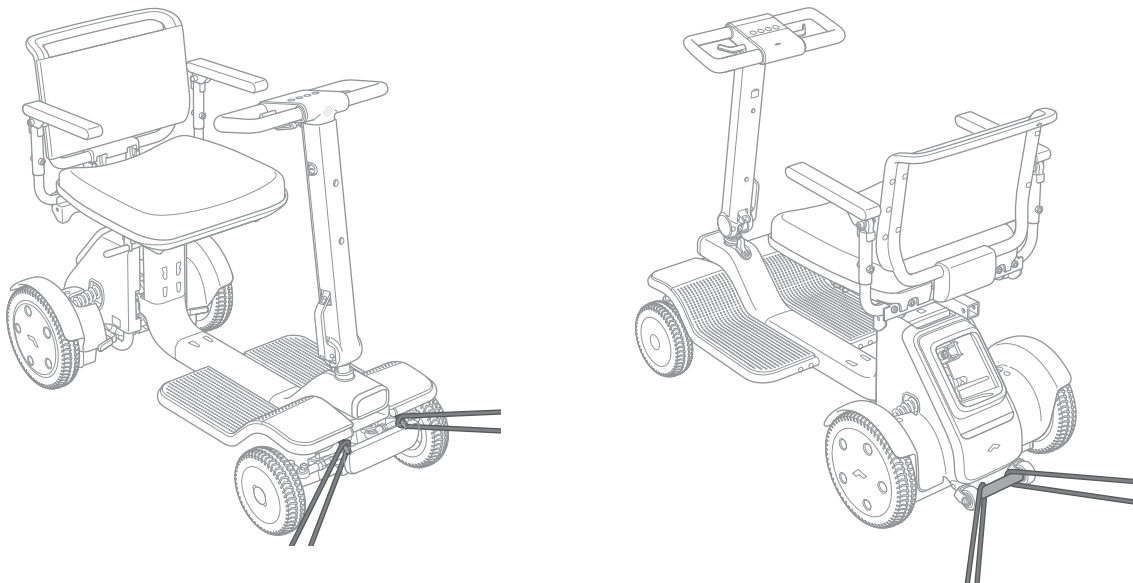

Front bumper frame and bar between anti-tip rollers (rear)

3-Wheel type

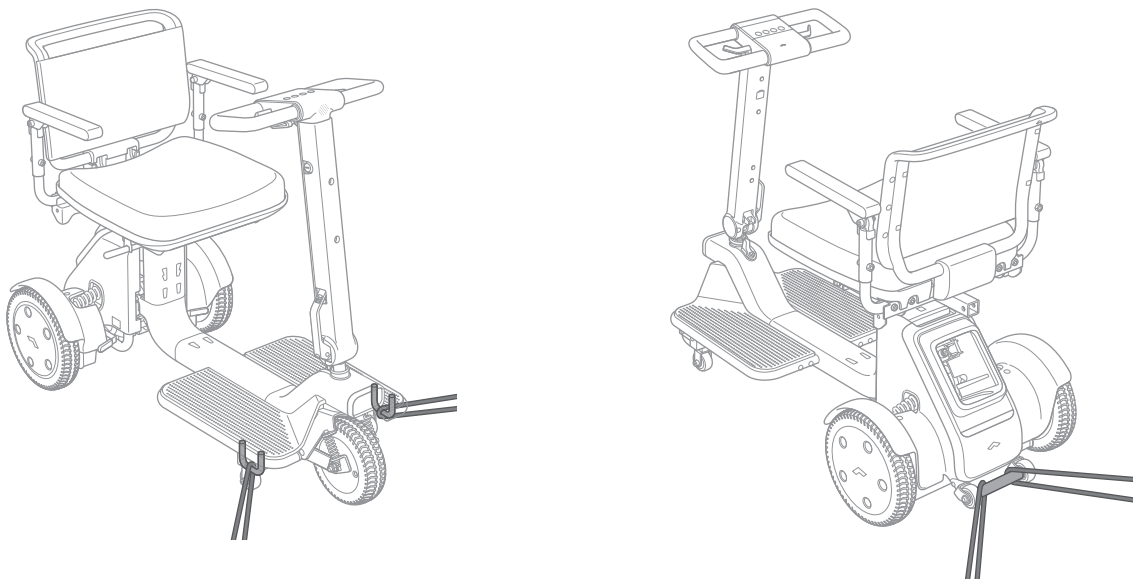

Footrest frames near anti-tip rollers (front) and bar between anti-tip rollers (rear)

7. About the smartphone app

This chapter describes the apps used in this product.

If you install the WHILL app on a device with Apple iOS (such as iPhone or iPad) or on a smartphone with Google Android OS, you can configure the device settings of WHILL Model R series from the app via Bluetooth Low Energy (BLE). The device utilizes Bluetooth Generic Attribute Profile (GATT) for communication.

The app can be used to turn the device on and off, check the device status, and set the mode. Use the app within connectable distance (approximately 10 m (32.8 ft), varying depending on environment) close to the device, otherwise degradation of wireless function (e.g., firmware update) may occur.

For the safety information regarding radio frequency interference, refer to "1.4. EMI (Electromagnetic Interference)".

Time synchronization of WHILL Model R series with the local time can also be accomplished via the app over BLE connection, but this function can only be executed by WHILL.

Depending on your region, time of day, and the type of smartphone, the app may not be available, or some features may not be available.

Please keep the label printed with the ID and password of the included app registration on the last page of this manual to prevent it from being lost. Do not attach to the device.

CAUTION



- After changing the mode setting, ensure that this device is functional in a safe place. Otherwise, this device might move unexpectedly.



When operating the power supply of this device on a smartphone app, pay attention to the battery charge level of the smartphone. The power supply of this device can no longer be operated if the smartphone battery runs out.

8. Maintenance and inspection

WARNING



- Do not perform maintenance or inspection on locations that are not listed in this manual. There is a risk of injury and product safety risk due to damage to this device or its parts. Performing maintenance or inspection which is not listed in this manual will invalidate the warranty.
- Before performing maintenance and inspection, turn this device power supply OFF. There is a risk of unexpected movement of this device caused by accidental contact with the controller unit.



If you cannot perform adjustment or inspection by yourself, contact your distributor or customer support. Only trained staff are permitted to perform maintenance on this device.

8.1. Cleaning, disinfection and user maintenance

Perform maintenance on this device as follows.

- If there is a significant amount of dirt on the exterior or wheels, wipe it away with a wet towel. Pay attention when washing the wheels off with water.
- If the dirt is tough to remove, use a neutral detergent. Avoid the use of petroleum-based solvents.
- Do not use a high-pressure washer.
- When disinfecting this device or parts, wipe gently with a soft cloth moistened with commercially available alcohol disinfectant.
- Replace the front and rear wheels when the treads are worn down by less than 1/64 inches (0.5 mm).
- If there is a foreign object on the battery connector socket or battery connector port, remove it with a small brush, etc.
- If there is a foreign object on the drive base connector socket or main body connector port, remove it with a small brush, etc.
- If this device, parts or tires have any abnormal appearance such as cracks, stop using this device immediately and contact your distributor or customer support.

WARNING



- Do not touch the battery connector socket or battery connector port directly, allow them to become wet, or bring foreign objects close to them. Otherwise, there is a risk of injury or electric shock and of damage to this device or its parts.
- Do not touch the drive base connector socket or main body connector port directly, allow them to become wet, or bring foreign objects close to them. Otherwise, there is a risk of injury or electric shock and of damage to this device or its parts.

CAUTION

- Do not use paint thinner, benzene, or other organic solvents for cleaning, and do not use a high-pressure washer.
Doing so may result in discoloration, deformation, deterioration, and damage.
- Wipe off dirt on the surface of the controller unit with lens cloth or other soft cloth.
Wiping with a hard cloth, etc. may damage the screen.
- Do not apply commercially available grease or oily antirust agent/wax, etc. to the moving parts or connections of this device.
There is a risk that the stickiness of such substances may cause sand or other foreign substances to enter this device, causing device malfunction.

8.2. Inspection

To ensure the safe use of this device, it is recommended that you have this device inspected approximately once every six months by your distributor. For details, contact your distributor or customer support.

8.3. Repair performed by the manufacturer or distributor

If repair is necessary, contact your distributor or customer support.

WARNING

- If this device shows any abnormal signs, immediately discontinue use, and contact your distributor or customer support.
Continuing to use this device when it is malfunctioning can potentially cause an injury or unexpected accident.

CAUTION

- If a part deteriorates or becomes worn, and requires replacement, contact your distributor or customer support.
The part might become damaged and render it inoperable.

8.4. Disposal

When disposing of this device, parts and battery, be sure to follow the local disposal guidelines. If there is anything that is unclear, contact your distributor or customer support.

8.5. Product warranty

For device warranty information, check its warranty.

8.6. Reuse information

The scooter is suitable for reuse. Before the scooter is passed on to another user, it must be serviced and hygienically prepared by a specialist dealer. When passing on the scooter, please remember to give these operating instructions and the address of your specialist dealer to the new user.

8.7. How to check the manufacture date of the device

■ Device

Check the 5th to 7th digits from the end of the serial number listed on the primary identification label (see Page 23).

Indication	Year	Month
Indicated location	6th and 7th digits from end	5th digit from end
Notation method	24 : 2024 25 : 2025 26 : 2026 27 : 2027 28 : 2028	1 to 9: January to September A : October B : November C : December

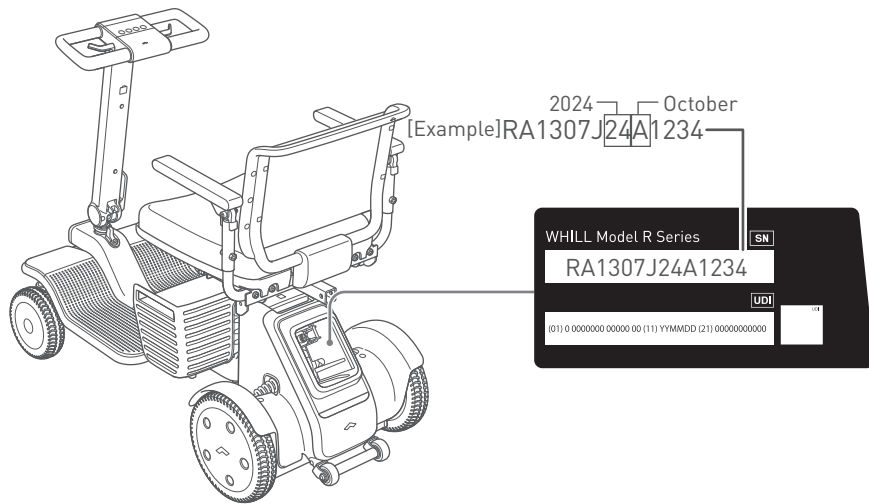

■ Battery

Check the 11th to 13th digit from the end of the 16-digit serial number listed in the white frame of the label of the battery.

Indication	Year	Month
Indicated location	13th digit from end	11th and 12th digits from end
Notation method	4 : 2024 5 : 2025 6 : 2026 7 : 2027 8 : 2028	01 : 1st week 02 : 2nd week • • 52 : 52nd week

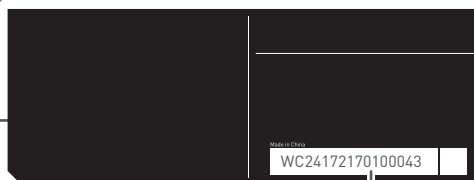
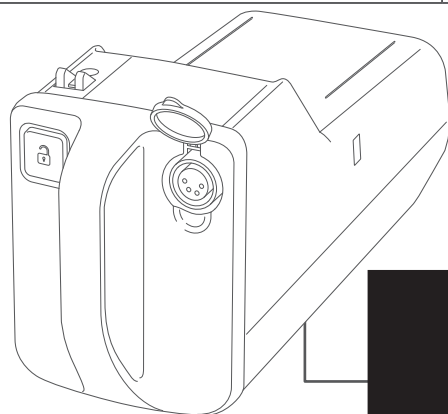

[Example] WC24172170100043
2024 → 17th week

■ Charger

Check the 6th and 7th digit from the end of the 11-digit serial number listed in the white frame of the label of the charger.



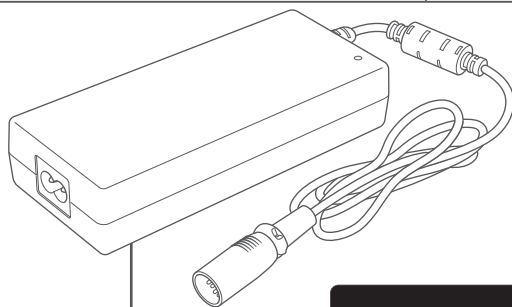



Indication	Year	Month
Indicated location	7th digit from end	6th digit from end
Notation method	4 : 2024 5 : 2025 6 : 2026 7 : 2027 8 : 2028	1 to 9: January to September A : October B : November C : December



[Example] 6JWW47L000S
2024 → July

9. Troubleshooting

In the event of certain issues with this device, an error code will be displayed on the controller unit display. The following table summarizes error displays, audio messages, causes of the errors, and how to remedy the errors.

Error Display/Issue	Message	Cause	Resolution
	Restart without touching the throttle lever.	The power was turned ON while the throttle control lever was being operated.	Turn the power ON again without operating the throttle control lever.
	Pull up the red brake release levers and restart.	The power was turned ON while the brakes were released, or the brakes were released while the power was ON.	Apply the brakes, and turn the power ON again.
	Driving temporarily disabled due to motor overload.	An excessive load was applied temporarily on the motor control section.	Turn the power ON again.
	Driving temporarily disabled due to motor overload.	An excessive current was detected temporarily.	Turn the power ON again.
	Battery level low. Please charge.	Battery charge level is low.	Charge the battery.
	N/A	The power was turned ON while the charger was connected, or the charger was connected while the power was ON.	Disconnect the charger from the battery, and turn the power ON again.
The maximum speed decreases.	Battery temperature low. Speed restricted.	The battery temperature dropped significantly.	Store the battery in an ambient temperature of 0°C (32°F) or above until the battery temperature reaches 0°C (32°F).
The device power supply does not turn ON.	N/A	The battery charge level is low.	Charge the battery.
		The battery is not correctly inserted into the battery compartment.	Correctly insert the battery into the battery compartment.
		A battery error has occurred.	Remove the battery, then wait at least 10 seconds before inserting the battery again into the battery compartment.

10. Specifications

Product Specification Sheet	
Model	WHILL Model R Series
Scooter class	A
Occupant mass group	III
Name and address of the product manufacturer	WHILL, Inc. 2-1-11 Higashishinagawa, Shinagawa-ku, Tokyo 140-0002, Japan

Dimensions and weight		Minimum Value	Maximum Value
IS07176-5	Overall length*	-	3-wheel type: 1,110 mm (43.7 in.) 4-wheel type: 1,143 mm (45 in.)
IS07176-5	Overall width	535 mm (21.1 in.)	635 mm (25 in.)
IS07176-5	Handgrip height	895 mm (35.2 in.)	913 mm (35.9 in.)
IS07176-5	Stowage length of Main body	-	287 mm (11.3 in.)
IS07176-5	Stowage width of Main body	-	535 mm (21.1 in.)
IS07176-5	Stowage height of Main body	-	435 mm (17.1 in.)
IS07176-5	Stowage length of Drive base	-	3-wheel type: 908 mm (35.7 in.) 4-wheel type: 912 mm (35.9 in.)
IS07176-5	Stowage width of Drive base	-	3-wheel type: 457 mm (18 in.) 4-wheel type: 485 mm (19.1 in.)
IS07176-5	Stowage height of Drive base	-	3-wheel type: 386 mm (15.2 in.) 4-wheel type: 390 mm (15.4 in.)
IS07176-5	Stowage length of Seat	485 mm (19.1 in.)	520 mm (20.5 in.)
IS07176-5	Stowage width of Seat	535 mm (21.1 in.)	635 mm (25 in.)
IS07176-5	Stowage height of Seat	318 mm (12.5 in.)	425 mm (16.7 in.)
IS07176-5	Folded length	-	3-wheel type: 1,110 mm (43.7 in.) 4-wheel type: 1,160 mm (45.7 in.)
IS07176-5	Folded width	535 mm (21.1 in.)	635 mm (25 in.)
IS07176-5	Folded height	835 mm (32.9 in.)	855 mm (33.7 in.)
IS07176-5	Rising	-	10 mm (0.39 in.)
IS07176-5	Reversing width	3-wheel type: 1,480 mm (58.3 in.) 4-wheel type: 1,490 mm (58.7 in.)	-
IS07176-5	Required width of angled corridor	3-wheel type: 1,112 mm (43.8 in.) 4-wheel type: 1,120 mm (44.1 in.)	-
IS07176-5	Required doorway entry depth	3-wheel type: 1,004 mm (39.5 in.) 4-wheel type: 1,020 mm (40.2 in.)	-

Dimensions and weight		Minimum Value	Maximum Value
IS07176-5	Required corridor width for side opening	3-wheel type: 1,006 mm (39.6 in.) 4-wheel type: 1,026 mm (40.4 in.)	-
IS07176-7	Seat plane angle	-	3.5°
IS07176-7	Effective seat depth	-	432 mm (17 in.)
IS07176-7	Effective seat width	-	432 mm (17 in.)
IS07176-7	Seat surface height at front edge	524 mm (20.6 in.)	544 mm (21.4 in.)
IS07176-7	Backrest angle	-	8.5°
IS07176-7	Backrest height	-	355 mm (14 in.)
IS07176-7	Footrest to seat distance	352 mm (13.9 in.)	372 mm (14.6 in.)
IS07176-7	Leg to seat surface angle	-	86.5°
IS07176-7	Armrest to seat distance	210 mm (8.3 in.)	258 mm (10.2 in.)
IS07176-7	Front armrest-to-backrest distance	-	264 mm (10.4 in.)
IS07176-5	Total mass (including battery)	-	3-wheel type: 52.2 kg (115.1 lbs.) 4-wheel type: 56.8 kg (125.2 lbs.)
IS07176-5	Mass of heaviest component when disassembled	-	3-wheel type: 20.3 kg (44.8 lbs.) 4-wheel type: 20.9 kg (46.1 lbs.)
-	Drive base weight	-	3-wheel type: 16.3 kg (35.9 lbs.) 4-wheel type: 20.9 kg (46.1 lbs.)
-	Main body weight	-	20.3 kg (44.8 lbs.)
-	Seat weight	-	12 kg (26.5 lbs.)
-	Basket weight	-	0.9 kg (2 lbs.)
-	Battery weight	-	2.7 kg (6 lbs.)
IS07176-7	Horizontal location of axle	-	58 mm (2.3 in.)
-	Wheelbase	-	3-wheel type: 840 mm (33.1 in.) 4-wheel type: 853 mm (33.6 in.)

* This specification can be subjected to a variance of (+ or -) 20 mm (0.8 in.).

Performance		Minimum Value	Maximum Value
-	Maximum weight limitation	-	147 kg (325 lbs.)
ISO7176-1	Static stability, forward scooter tipping angle, wheels unlocked	-	10°
ISO7176-1	Static stability, rearward scooter tipping angle, wheels locked	-	10°
ISO7176-1	Static stability, rearward scooter tipping angle, wheels unlocked	-	10°
ISO7176-1	Static stability, lateral scooter tipping angle	-	10°
ISO7176-1	Static stability, rearward anti-tip device tipping angle	-	10°
ISO7176-2	Forward dynamic stability on ramp	-	10°
ISO7176-2	Rearward dynamic stability on ramp	-	10°
ISO7176-2	Lateral dynamic stability on ramp	-	10°
ISO7176-2	Lateral dynamic stability while turning in a circle	-	10°
ISO7176-2	Lateral dynamic stability while turning suddenly	-	10°
ISO7176-2	Rearward dynamic stability traversing step forward	-	50 mm (2 in.)
ISO7176-2	Rearward dynamic stability traversing step backward	-	50 mm (2 in.)
ISO7176-2	Forward dynamic stability traversing forward up a step	-	50 mm (2 in.)
ISO7176-2	Forward dynamic stability traversing forward down a step	-	50 mm (2 in.)
ISO7176-2	Travelling forward at an oblique angle to a downward step	-	50 mm (2 in.)
ISO7176-10	Obstacle climbing height	-	50 mm (2 in.)

Performance		Minimum Value	Maximum Value
-	Ability to climb rated slope	-	10°
ISO7176-6	Maximum speed forward	-	8 km/h (5 mph) or 6 km/h (3.7 mph)*
-	Maximum speed backward	-	2 km/h (1.2 mph)*
ISO7176-4	Theoretical continuous driving range	-	3-wheel type: 18.7 km (11.6 miles) 4-wheel type: 17.2 km (10.7 miles)
ISO7176-3	Running brakes, normal operation	-	3-wheel type: 1,330 mm (52.4 in.) 4-wheel type: 1,360 mm (53.5 in.)
ISO7176-3	Running brakes, reverse operation	-	3-wheel type: 1,183 mm (46.6 in.) 4-wheel type: 1,137 mm (44.8 in.)
ISO7176-3	Running brakes, emergency operation	-	1,110 mm (43.7 in.)
ISO7176-3	Parking brakes, maximum slope uphill	-	10°
ISO7176-3	Parking brakes, maximum slope downhill	-	10°
-	Gap stepping over depth forward	-	100 mm (3.9 in.)
ISO7176-5	Minimum turning radius	3-wheel type: 910 mm (35.8 in.) 4-wheel type: 970 mm (38.2 in.)	-
ISO7176-5	Ground clearance	55 mm (2.2 in.)	-
-	Waterproof level	-	IPX5
-	Basket capacity	-	15L / 6 kg (13.2 lbs.)

* Maximum speed forward and backward have been tested with a loading of 147 kg (325 lbs.). The limit of forward speed is ruled by local regulations. In the EU, the limit is 6 km/h (3.7 mph) in the UK, Germany, Austria, and the rest of the EU is specified as 8 km/h (5 mph). In Asia and Oceania, Hong Kong, Australia, and New Zealand, the limit is up to 8 km/h (5 mph). In the U.S. and Canada, it is up to 5 mph (8 km/h).

Control force	Minimum Value	Maximum Value
Throttle control lever	-	15 N
Buttons	10.2 N	18 N
Brake release lever	8.6 N	17 N
Wheels		
Front wheel type	Solid	
Front wheel dimensions	194 mm (7.6 in.)	
Rear wheel type	Solid	
Rear wheel dimensions	265 mm (10.4 in.)	
Motor		
Type	Brushless motor	
Rated voltage	DC24 V	
Brake		
Type	Electromagnetic brake	
Battery		
Type	Lithium-ion battery	
Nominal voltage	25.3 V	
Rated capacity (5-hour rate)	10.6 Ah	
Battery charger (Dedicated for Model R series)		
Type	Off-board battery charger	
Rated power	100-240 V, 50/60 Hz	
Rated DC output current	2.4 A	
Rated DC output voltage	28.49 V	
Operating temperature and charging temperature	0 to 40°C (32 to 104°F)	
Supported battery type	Lithium-ion battery	
Charging time	5 hours	
DC connector pinout	Pin 1: +	
	Pin 2: -	
	Pin 3: Detection	
	Pin 4: Not connected	
Rated current of user-accessible protective fuses	There are no user-accessible fuses	
Name and address of the battery charger manufacturer	WHILL, Inc. 2-1-11 Higashishinagawa, Shinagawa-ku, Tokyo 140-0002, Japan	

Antenna	
Type	Bluetooth Low Energy
Frequency	2402 - 2480 MHz
Maximum output power	6 dBm

Environment	Minimum Value	Maximum Value
Operation temperature	-15°C (5°F)	40°C (104°F)
Operation humidity	8%	90%
Storage temperature (Battery & Charger)	0°C (32°F)	40°C (104°F)
Storage temperature (Device)	-15°C (5°F)	40°C (104°F)
Storage humidity (Battery & Charger)	25%	50%
Storage humidity (Device)	8%	90%
Miscellaneous	Minimum Value	Maximum Value
Estimated lifespan	-	5 years
Noise produced by the device and level thereof	-	65 dBA

The scooter conforms to the following standards:

- Requirements and test methods for static, impact, and fatigue strengths (ISO 7176-8)
- Power and control systems for electric scooters - requirements and test methods (ISO 7176-14)
- Climatic test in accordance with ISO 7176-9
- Requirements for resistance to ignition in accordance with ISO 16840-10

Note:

- 1) The maximum speed may be lowered to meet local regulations.
- 2) The test results are based on the maximum speed set at 8 km/h (5 mph).

■ Declaration of Conformity for CE Marking

Hereby, WHILL, Inc. declares that WHILL Model R is in compliance with Directive 2014/53/EU, Regulation 2023/1230/EU, Directive 2011/65/EU, Regulation 1907/2006 and Regulation (EU) 2017/745. The full text of the EU declaration of conformity is available at the following internet address: <https://whill.inc/>

■ Disposal in the European Union



The device, battery and accessories are durable components. Improper disposal of waste products may result in the release of environmentally hazardous substances. This symbol (picture left) means that this device must be disposed of in accordance with the European Directive 2012/19/EC (WEEE Directive). To protect the environment, have the device picked up at the end of its life at a local recycling center.

■ Reusability

Please follow the instructions under 8.6. if you pass the vehicle on to another user. To ensure the safe use of the vehicle, any adjustment and cleaning should be carried out according to the instructions in 3.4., 5.1. and 8.1.

Index

A	
Accessory	24
Accessory mount	22
Adjusting the speed	75
Adjustment.....	26
Adjustment procedures	39
Adjusting the height of the armrests.....	46
Adjusting the light angle of the front light.....	47
Adjusting the seat forward/backward position.....	43
Adjusting the seat height	41
Adjusting the space between armrests	45
Adjusting the tiller unit angle	40
Anti-tip roller (front)	22
Anti-tip roller (rear)	22
Armrests	22
Assembly.....	26
Assembly procedures	29
Armrests	28, 37
Basket.....	28, 35
Battery.....	29, 37
Charger	29
Drive base.....	27, 30
Main body	27, 30
Seat base.....	28, 36
Seat cushion.....	28, 36
Seat post.....	27, 34
Tiller cover	33
Tiller cover (front)	27
Tiller cover (rear)	28
Tiller unit.....	32
B	
Back support.....	22
Basket	22
Battery.....	22, 55
Battery charging port.....	55
Battery LED	55
Battery lock release button	55
Handle	55
Battery connector port	11
Battery connector socket.....	11
Brake release lever.....	22
C	
Carrying items	78
Charger	22, 55
AC connector cord.....	55
AC receptacle	55
Charger indicator	55
DC connector.....	55
Charger indicator displays.....	60
Charging procedures	55
Charging the battery	52
Checking the battery charge level.....	68
Cleaning, disinfection and user maintenance.....	88
Contact information	103
Controller unit.....	22
D	
Disassembly.....	26
Disassembly procedure	47
Display.....	22
Disposal	89
Driving.....	70
Moving forwards and backwards	74
Stopping	75
Turning	74
Turning corners.....	74
E	
EMI (electromagnetic interference)	12
F	
Footrest.....	22
Footrest frame	30
Frame release lever.....	22, 31
Front bumper	22
Front light	22
Front light button	22
Front wheels	22
H	
Horn button.....	22
How to avoid an emergency situation.....	9
How to check the manufacture date of the device	90

I		Tiller unit.....	22
Inspection.....	89	Transporting this device	81
Inspection before getting in this device.....	63	Troubleshooting	92
K		Turning the power supply OFF.....	76
Key cylinder.....	22	Turning the power supply ON	67
L		U	
Light angle adjustment lever.....	47	USB port.....	22
M		User maintenance	88
Manufacturer information label	23		
N			
Names of parts	27		
O			
Operating procedures	62		
P			
Precautions during driving	10		
Primary identification label	23		
Product warranty	89		
R			
Rear light	22		
Rear wheels	22		
Releasing the brakes	77		
Repair.....	89		
Required tools.....	29		
Reuse information	90, 99		
S			
Safety lock.....	31		
Safety precautions	6		
Seat cushion	22		
Seat rotation lever	66		
Seat rotation stopper	34		
Securing this device.....	84		
Serial number label.....	23		
Smartphone app	86		
Speaker	22		
Specifications.....	94		
Speed select button	22		
Storage.....	80		
Symbols.....	100		
T			
Throttle control lever	22		
Tiller adjustment lever	22, 32		
Tiller handle.....	22		