



# C.T.M. Power Chair

HS-2750 User Manual



# Table of Contents

1.INTRODUCTION	1
2.IMPORTANT PRECAUTIONS	2
3.PRODUCT OVERVIEW	6
4.PRODUCT OPERATION	8
5.BATTERIES AND CHARGING	11
6.TROUBLE SHOOTING	13
7.MAINTENANCE AND CLEANING	15
8.ACCESSORIES	17
9.SPECIFICATION	18

## 1. INTRODUCTION

**Thank you and congratulations on purchasing your new C.T.M. Power Chair. It is designed to provide you with transportation ability indoors and outdoors.**

We pride ourselves on providing safe and comfortable products. Our goal is to ensure your complete satisfaction with our product. We are certain that you will enjoy your C.T.M. Power Chair.

Please read and observe all warning and instruction provided in the owner's manual before operating this power chair. Also, retain this booklet for future reference.

In case of a serious incident with the product, you should inform the manufacturer and the competent authority in your country.

**If you have any questions, you can contact:**



### **CHIEN TI ENTERPRISE CO., LTD.**

No. 13, Lane 227, Fu Ying Rd., Hsin Chuang Dist.,  
New Taipei City, Taiwan, R.O.C.

Tel : +886-2-2903-2987 Fax : +886-2-2903-8807

E-Mail : [sales@chienti.com.tw](mailto:sales@chienti.com.tw) [http : //www.chienti.com.tw](http://www.chienti.com.tw)

**Information of European Representative :**



**MedNet EC-REP GmbH**

Borkstrasse 10, 48163 Muenster, Germany

## 2.IMPORTANT PRECAUTIONS

### 2-1 CAUTIONS BEFORE DRIVING

#### ※Drive for the first time :

- 1.Before take the first trip with power chair, you should familiarize yourself well with the operation of power chair and with the operation elements. Please take your time to read this introduction booklet.
- 2.Before driving, please evaluate the personal condition, and fully understand the operation of power chair.
- 3.Batteries should be fully charged before your journey for maximum performance and longevity (see section 5-2 ).
- 4.The maximum load of the power chair is 150KG. Do not exceed the maximum permissible load. Exceeding the max.weight rating may result in injury to yourself.
- 5.The power chair is only designed for use by a single occupant whose maximum weight does not exceed the maximum permissible load of the device. Never use the power chair to transport more than one person (including children).

#### ※Before each ride :

- 1.Please make sure the left / right levers is in Drive position. Do not sit on the power chair when the left / right levers is in Neutral position. The chair could roll down on its own, causing injury. (see section 4-4)
- 2.Inspect the tire pressure (if it is sufficient) and tire tread depth.
- 3.Check if all devices, connectors and wiring are connected properly and if all parts are tightened firmly.
- 4.Please always set the speed control to its lowest speed before powering on. Check the battery gauge and status indicator to ensure everything works fine before driving. (see section 4-1)



Watch out the condition of weather before every journey and prepare the necessary rain shade to avoid danger of remote defect or system malfunction. In case of getting wet because of the unexpected bad weather, find a shelter immediately and wipe the power chair with a dry cloth.



- 1.Mobility device may only be used on the traffic routes for which it is approved in accordance with the relevant national legislation.
- 2.Do not drive on a slope which is over the limit. Please bypass, do not drive to across the obstacle over the limit. (see section 9)
- 3.Do not drive your power chair if you are under the influence of alcohol or medication that may affect your ability.
- 4.Do not stand on the footrest when get in or out of the seat. Step on the ground to get in the seat and step on the footrest only when you seat securely.
- 5.Do not wear loose clothes or long skit to avoid rolling into the tire and causing danger.
- 6.You should not assemble, maintain, and operate the power chair before you read this instruction booklet.
- 7.Do not attempt to modify or dismantle the battery box or carry out any maintenance work that is not described in this user manual.
- 8.Do not change, modify, remove any parts from products especially safety protected parts such as anti-tippers.
- 9.Any unauthorized modification is prohibited. Please do not attempt to modify the power chair.
- 10.Please observe all relevant rules and regulations pertaining to pedestrians and road users at all times when you are driving the power chair.
- 11.Always be aware of pedestrians and situations which might require extra care when using your power chair on public walk ways and footpaths.

### 2-2 CAUTIONS WHEN DRIVING

- 1.Do not attempt to drive the power chair under below hazardous road condition. If necessary, please drive it in the presence of an attendant :
  - Dark, bad weather such as in rain, snow, mist, storm, and poor visibility.
  - Narrow paths, level crossing, and uneven terrain.
  - Wet grass, sand, gravel, or any other potentially hazardous condition.
- 2.Do not store the power chair in a humid condition such as rain or show as this may cause damage to electronics or corrosion to frame.

3. Do not place the power chair on a slope to avoid roll-away and danger.
4. Do not turn the power on before you get in and sit securely on the seat. Be certain that the power is turned off when get in, get out. This will eliminate the possibility of accidentally activating the remote module and causing injury.
5. When turning, reduce your speed and maintain a stable center of gravity. This greatly reduces the possibility of a tip or fall.
6. Do not stretch your body out on the power chair.
7. Do not operate on staircases or escalators.
8. Please always set the speed control to its lowest speed when you start to drive, and observe all relevant rules and regulations pertaining to pedestrians and road users at all times.
9. Do not make S turns or sharp turns while driving. This may cause the power chair to tip.



Upon encountering extreme weather (rain, fog, snow, etc), immediately find cover and use dry towel to wipe down the power chair

**2-3 CAUTIONS WHEN DRIVING ON INCLINE (SEE SECTION 9.)**

- For maximum stability, lean forward in your body while proceeding up ramps, inclines, curbs, or any low rise. (please refer to following picture)



- The weight capacity limit is 150kg at 6 degree ramp (please refer to above picture).
- Your power chair's ability to travel up inclines is affected by your weight, your power chair's speed, your angle of approach to the incline, and your power chair setup.
- Never drive on a slope that exceeds the rated slope.
- When driving on ramp, adjust body center of gravity for power chair stability.



- When driving down a ramp or uneven terrain, keep the speed adjustment set to the slowest to ensure a safely controlled driving.
- If the speed is too fast, release the joystick, let the power chair stop. When you feel that you again have control of your power chair, push the joystick forward and continue safely driving.
- To prevent any danger, do not make turns on ascending, descending ramp.
- Please avoid to driving on a long ramp or any uneven terrain to prevent any danger from motor defected.
- Never place the power chair in freewheel mode (Neutral) on any sort of an incline or decline to avoid roll-away.
- Do not reverse when driving down a ramp.

**2-4 CAUTIONS WHEN CLIMBING**

- The maximum climbing angel is 6 degree.
- The maximum height of obstacle and curb that power chair can climb is up to 30 mm.

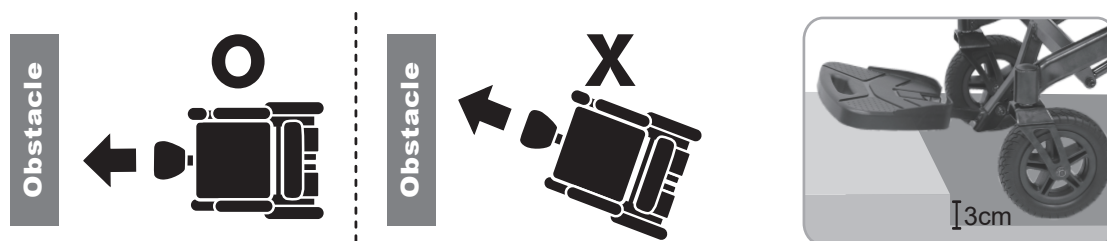

- When driving through an obstacle, stop the power chair. Keep it vertical with the obstacle and driving straight.



- Be mindful of road conditions and pass through obstacles slowly.
- Even though your power chair has been rated with maximum climbable, we suggest not driving through an obstacle.

## 2-5 ELECTROMAGNETIC INTERFERENCE AND WARNINGS

**CAUTION: It is very important that you read this information regarding the possible effects of Electromagnetic Interference on your power chair.**

Powered wheelchairs and motorized scooters may be susceptible to electromagnetic interference (EMI), which is interfering electromagnetic energy (EM) emitted from sources such as radio stations, TV stations, amateur radio (HAM) transmitters, two-way radios, and cellular phones. The interference (from radio wave sources) can cause the power chair to release its brakes, move by itself, or move in unintended directions. It can also permanently damage the power chair control system. The intensity of the interfering EM energy can be measured in volts per meter (V/m). Each power chair can resist EMI up to a certain intensity. This is called its "immunity level." The higher the immunity level, the greater the protection will be. At this time, current technology is capable of achieving at least a 20 V/m immunity level, which would provide useful protection from the more common sources of radiated EMI. The immunity level of this product is 20 V/m.

There are a number of sources of relatively intense electromagnetic fields in the everyday environment. Some of these sources are obvious and easy to avoid. Others are not apparent and exposure is unavoidable. However, we believe that by following the warnings listed below, your risk to EMI will be minimized.

### Electromagnetic Interference and Warnings :

The sources of radiated EMI can be broadly classified into three types:

1. Hand-held portable transceivers (transmitters-receivers) with the antenna mounted directly on the transmitting unit. Examples include: citizens band (CB) radios, "walkie talkie," security, fire, and police transceivers, cellular telephones, and other personal communication devices.



**Some cellular telephones and similar devices transmit signals while they are ON, even when not being used.**

2. Medium-range mobile transceivers, such as those used in police cars, fire trucks, ambulances, and taxis. These usually have the antenna mounted on the outside of the vehicle.
3. Long-range transmitters and transceivers such as commercial broadcast transmitters (radio and TV broadcast antenna towers) and amateur (HAM) radios.



**Other types of hand-held devices, such as cordless phones, laptop computers, AM/FM radios, TV sets, CD players, and cassette players, and small appliances, such as electric shavers and hair dryers, so far as we know, are not likely to cause EMI problems to your power chair.**

### Power Chair Electromagnetic Interference :

Because EM energy rapidly becomes more intense as one moves closer to the transmitting antenna (source), the EM fields from hand-held radio wave sources (transceivers) are of special concern. It is possible to unintentionally bring high levels of EM energy very close to the power chair control system while using these devices. This can affect power chair movement and braking. Therefore, the warnings listed below are recommended to prevent possible interference with the control system of the power chair.

**Warnings :**

Electromagnetic interference (EMI) from sources such as radio and TV stations, amateur radio (HAM) transmitters, two-way radios, and cellular phones can affect the power chair. Following the warnings listed below should reduce the chance of unintended brake release or power chair movement, which could result in serious injury.

1. Do not operate hand-held transceivers (transmitters-receivers), such as citizens band (CB) radios, or turn ON personal communication devices, such as cellular phones, while the power chair is turned ON;
2. Be aware of nearby transmitters, such as radio or TV stations, and try to avoid coming close to them;
3. If unintended movement or brake release occurs, turn the power chair OFF as soon as it is safe;
4. Be aware that adding accessories or components, or modifying the power chair, may make it more susceptible to EMI;
5. Report incidents of driving or brake malfunctions to the distributor listed on the first page of this manual and take note of any source of EMI.

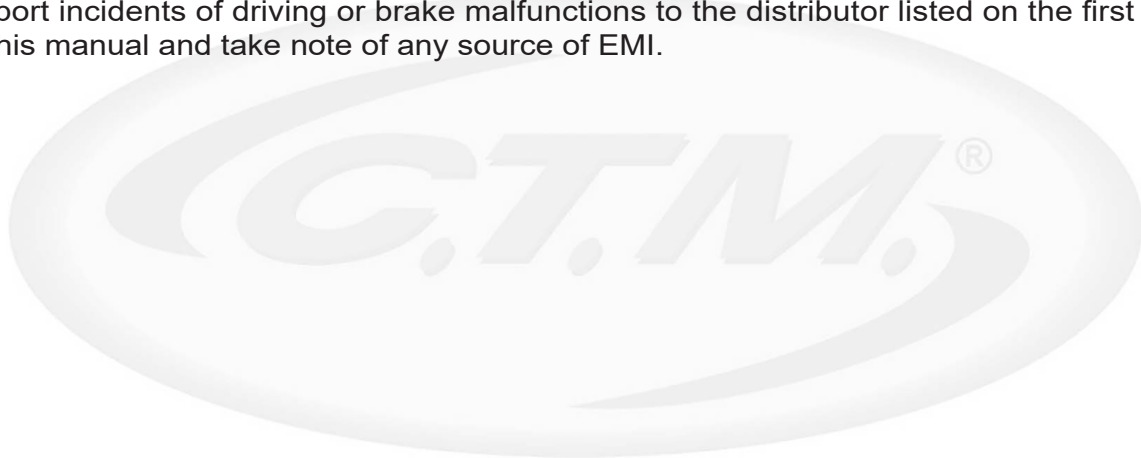

### 3.PRODUCT OVERVIEW

#### 3-1 LABELS INFORMATION

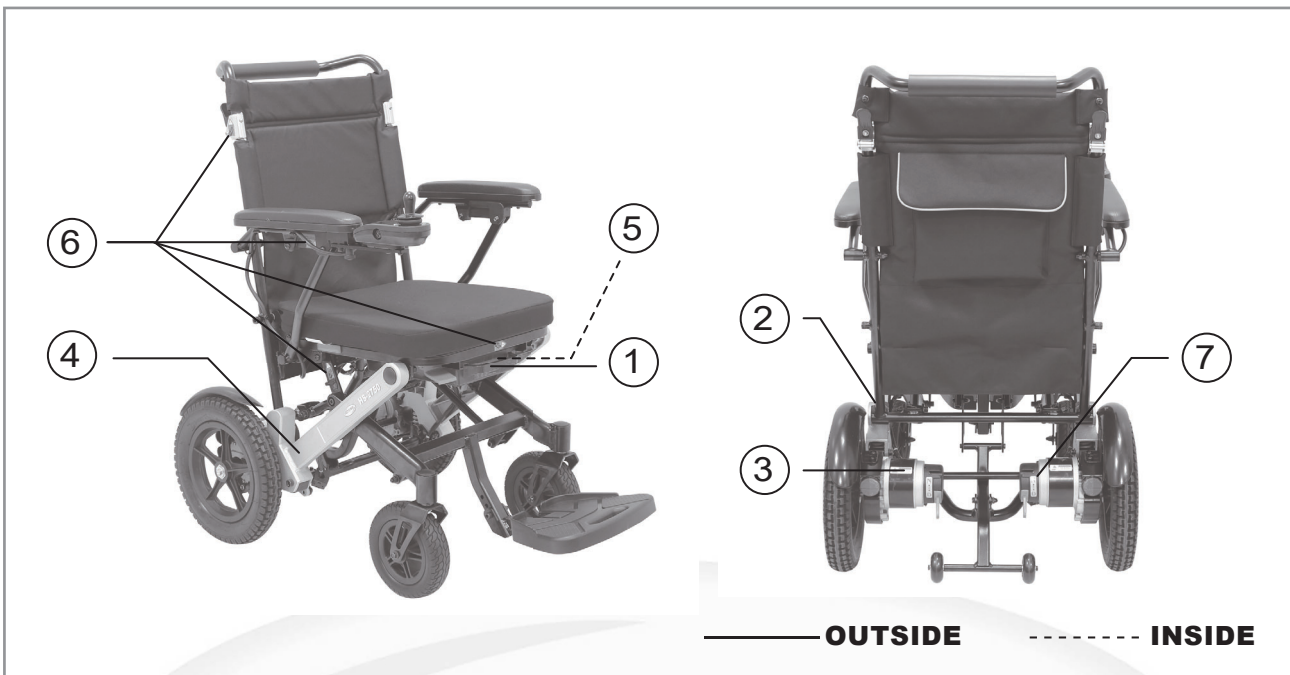

<p><b>1</b></p>	<p><b>Warning sticker</b></p> <ol style="list-style-type: none"> <li>1. Please read the instruction Booklet carefully before using your power chair.</li> <li>2. Keep the power chair properly maintained.</li> <li>3. Do not drive the power chair on slippery surfaces or on slopes over 6°.</li> <li>4. Do not drive on highways, crowded roads, or unfamiliar areas.</li> <li>5. Do not turn at high speed in either forward or reverse.</li> <li>6. Do not wash with water or leave power chair in a humid environment since water can damage the electronic parts.</li> <li>7. Always re-engage the emergency freewheel device after use.</li> </ol>	
<p><b>2</b></p>	<p><b>Information label</b> States the date of manufacture and serial number of the power chair.</p> <p> <b>SN</b> Serial Number      <b>EC REP</b> EU Authorized representative  <b>REF</b> Model Number      <b>MDI</b> Medical Device  <b>Date of Manufacture</b>      <b>CE</b> European Conformity  <b>Manufacturer</b>      <b>Consult Instructions for Use</b>  <b>Warning</b>      <b>Max:</b> Maximum weight capacity  <b>WEEE Conformity</b> </p>	
<p><b>3</b></p>	<p><b>Heat caution warning label</b> Be aware that the motor may normally become hot during operating. Please avoid skin contact.</p>	
<p><b>4</b></p>	<p><b>6</b></p>	<p><b>Pinch point warning label</b> Keep hands away</p>
<p><b>5</b></p>	<p><b>7</b></p>	<p><b>N-D Lever Adjustment label</b> Instructs freewheel mode operation.</p>



### 3.PRODUCT OVERVIEW

#### 3-2 IDENTIFICATION OF PARTS

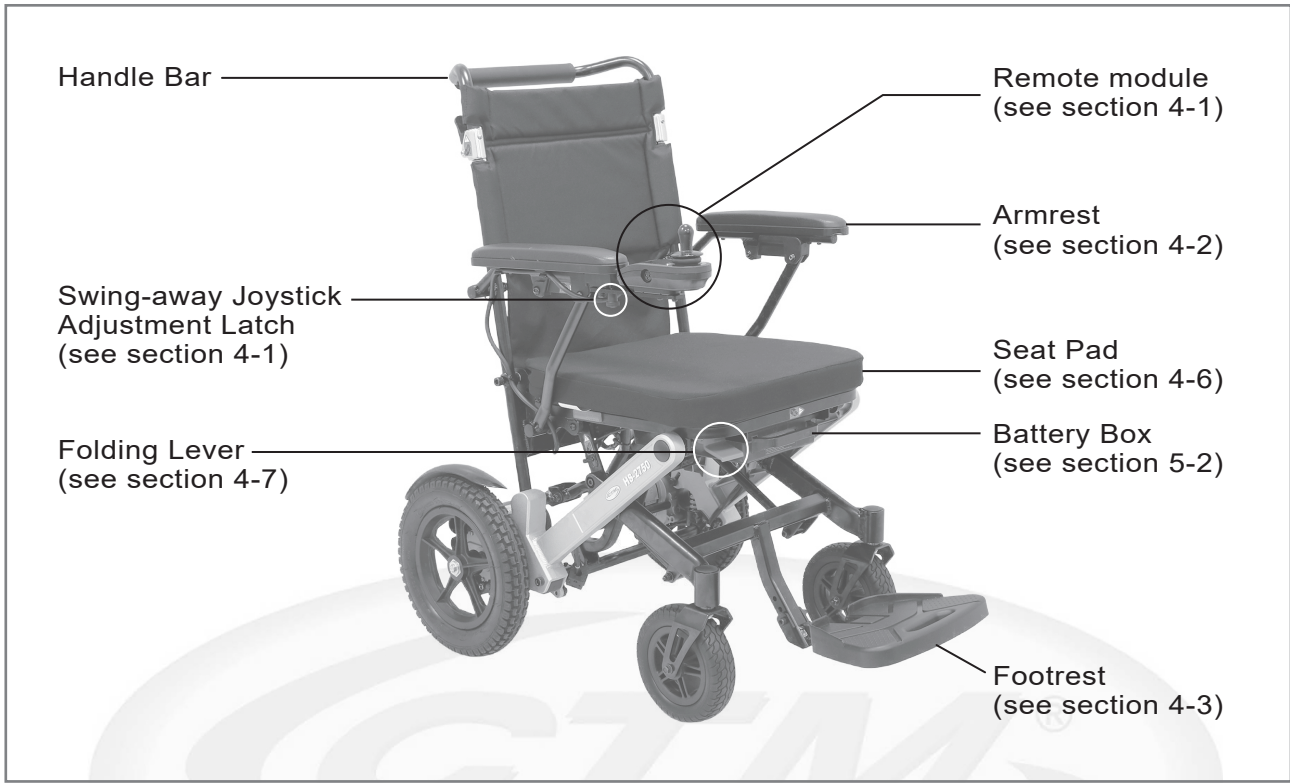

Figure 1 - HS-2750 Front View

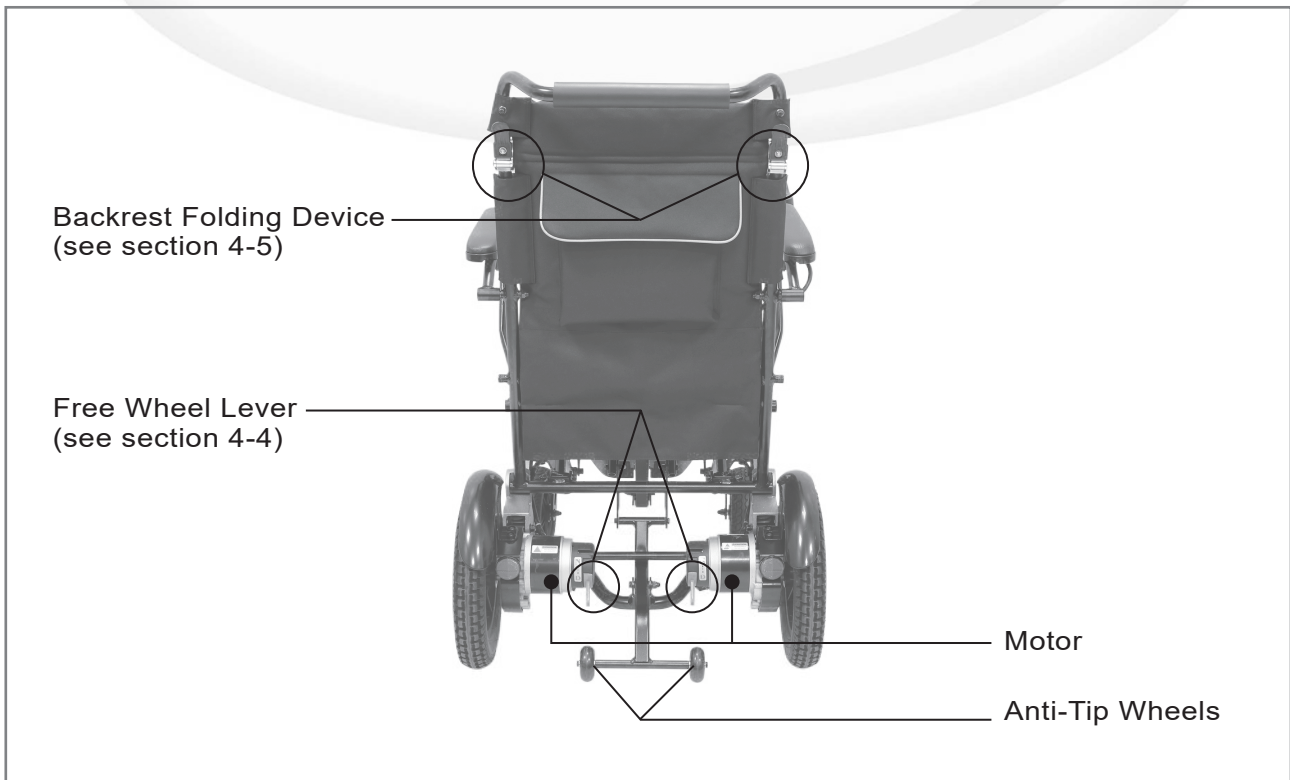

Figure 2 - HS-2750 Rear View

## 4.PRODUCT OPERATION

Before attempting to drive this power chair on your own, it is important that you familiarize yourself with the controls, and how to operate them.

**Intended use :** The C.T.M. Power Chair provide a means by which a disabled occupant i.e. a disabled person or a person not having the full capacity to walk unaided to have mobility and the freedom to travel.

**Indication :** The occupant is a person who requires a power chair due to current or anticipated mobility limitations. The C.T.M. power chair are intended to be applicable to at least 50% of adult users, based upon the body size of adult users within the range 50th percentile adult female to 50th percentile adult male the abilities and with vary in weight.

**Contra-indications :** None known.

### 4-1 REMOTE MODULE OPERATION

#### (A) Power button status indicator

Press the power button to switch on. The status indicator (through the power button) will light up green, and the battery gauge will display the current battery status.

Press the power button again to switch off the system. The system will power down and the status indicator will switch off.

#### (B) Battery gauge

The battery gauge comprises five different LEDs. The number of LEDs lit depends on the status of the battery (see section 5-3).

#### (C) Speed dial

(C1) Speed symbol

Dial set to the left to slow down.  
Dial set to the right to speed up.

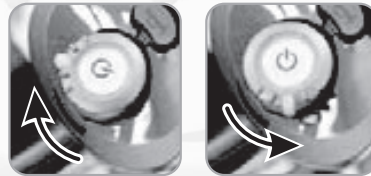

#### (D) Charger connector

The charger connector, which is located on the right-hand side of the Remote, is used to connect to a battery charger.

#### (E) Horn button

Press the horn button to sound the horn.

#### (F) Joystick

The joystick controls the direction and speed of drive. When the joystick is deflected from the neutral position, the wheelchair will move in the same direction as the joystick. (Fig.4) To stop driving, either pull the joystick back to the neutral position, or release the joystick and it will automatically return to the neutral position.

**Operation force : under 5N**

**Maximum currenxy : 43A**

#### (G) Joystick position adjustment latch (Fig 5)

Pull the latch (Fig.5-1) to rotate the joystick to desired position. (Fig. 5-2)

※Remove the wire harness before adjusting the joystick. (Fig. 5-3)

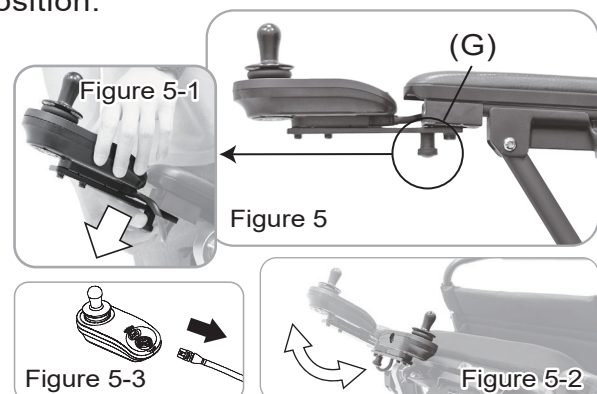
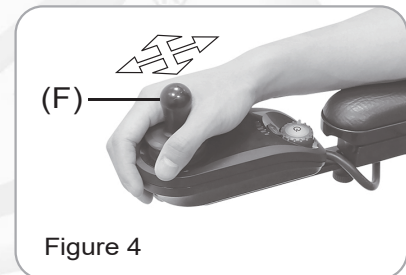
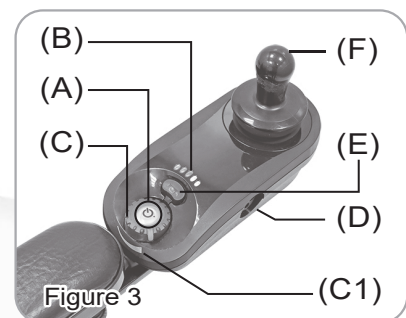

**4-2 ARMREST OPERATION**

Flip up the armrest to get off or get onto the wheelchair from one side. (Fig. 6)

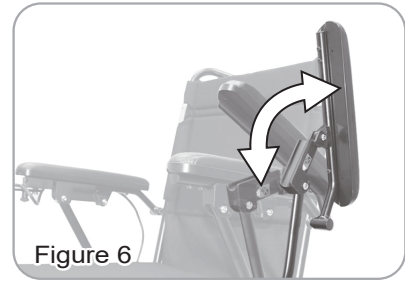

Figure 6

 **Watch out for pinch warning**

**4-3 FOOTREST ADJUSTMENT**

- Lift up footrest as arrows indicated to fold. (Fig. 7)
- Adjust the footrest fixation screw to required hole's position (3 heights) (Fig.7-1). Tighten the fixation screw if the footrest looses.

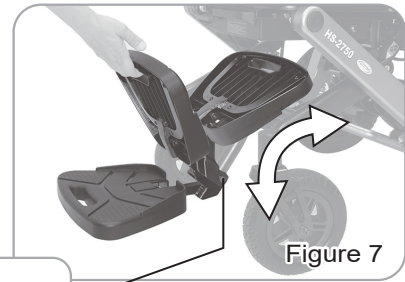



Figure 7

 **Do not stand on the footrest before sitting properly or when getting off the power chair to avoid any danger.**

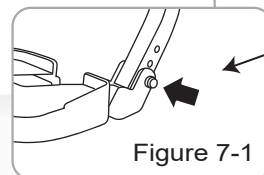



Figure 7-1

**4-4 FREE WHEEL OPERATION**

- In traveling, set the left / right levers to the Drive position. (Fig. 8)
- To push the power chair by hand or in the event of a fault or battery failure, the motors / gear boxes can be released allowing the power chair to be pushed. The left / right levers should be switched to the Neutral position. (Fig. 8-1)

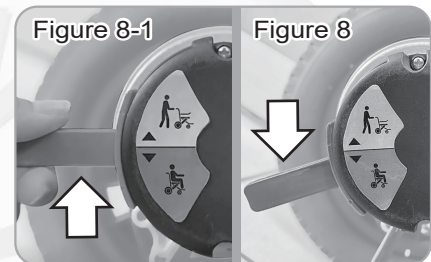



Figure 8-1

Figure 8

 **※ DO NOT use your chair while the drive are disengaged unless you are in the presence of an attendant. DO NOT disengage the drive motors when your chair is on an incline. The chair could roll down on its own, causing injury.**

**※ When adjusting N-D lever, do not sit on the power chair**

**4-5 BACKREST FOLDING OPERATION**

- Press down the left and right levers (Fig.9-1) to fold the backrest. (Fig.9)

 **Watch out for pinch warning**

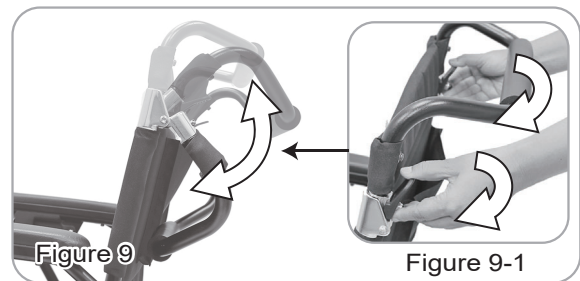

Figure 9

Figure 9-1

**4-6 SEAT PAD DISASSEMBLY**

- Pull off velcro of the seat pad to disassemble it. (Fig.10)

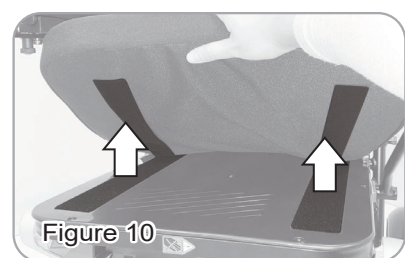
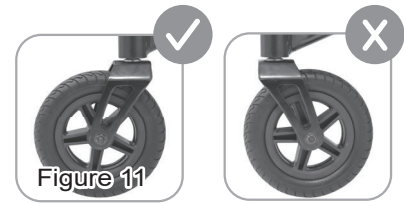

Figure 10

**4-7 FOLDING OPERATION**

**Folding:**

1. Confirm the front wheels are facing forwards for easier folding (Fig 11).
2. Lift up the folding lever under the seat and hold it still. (Fig 11-2).
3. Tug the seat and backrest inwards (Fig 11-3).
4. Release the folding lever to fold up the whole power chair. (Fig 11-4).
5. Fold the footrest upwards (Fig 11-5).
6. Use the front wheels to support its standing position. (Fig 11-6)



**Expanding:**

1. Lower the footrest.
2. Lift up the folding lever under the seat and hold it still. (Fig 11-2).
3. Push the seat and backrest outwards to expand (Fig 12).

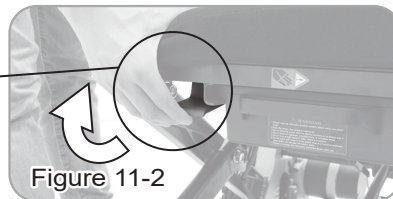

- For folding up the joystick bracket, please refer to chapter 4-1.
- Make sure the power chair is folded up in a steady standing position before letting go (Fig 11-6).
- This product can be tugged along over short distances, but the area around the anti-tip wheels must be free of obstacles.
- Adjust the gear lever to Neutral position before folding / expanding the power chair (refer to chapter 4-4).
- During the folding / expanding process, the fixation PIN must be firmly inserted into its hole (pictured below). Particularly during expansion, the PIN must be secure in position (bottom right figure) before mounting to operate to prevent serious danger.

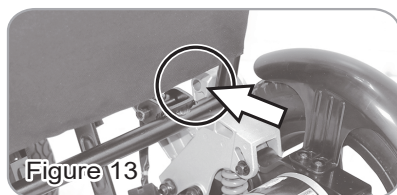

Folding positioning hole (inner side of frame)

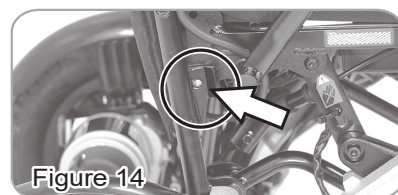

Expanding positioning hole (outer side of frame)

**4-8 AUTO-POWER OFF :**

Power will automatically be off if there is a system malfunction or circuit overload to ensure safety. Make sure the power chair is moved to a flat surface. Press the button (G) on the battery box and press the power button to activate the system.

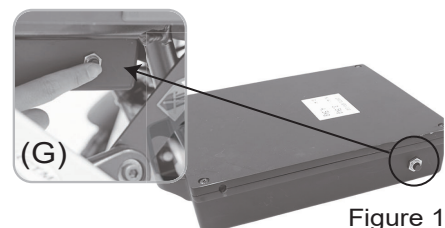

**4-9 SLEEP MODE**

- The power chair will go into sleep mode if no activity is detected for programmable time period. (Default programmable time is 10 mins.)
- To wake up the power chair, press the power button again.

## 5. BATTERIES AND CHARGING

※ Batteries must be fully charged before first use and recharged after each day use.

### 5-1 CAUTIONS FOR CHARGING

- Please read this section thoroughly before charging.
- Please turn the power off before charging and make sure to set the left/right levers to the Drive position. (see section 4-1/4-4)
- Please see section < 8.Product Specification > for the specification of lithium battery.
- Do not switch off, unplug or interrupt the recharge cycle until the charging cycle has completed (charger indicator turns green)
- Batteries must be charged before using the power chair for the first time. (see section 5-2)
- Full charge the batteries after each day's use. (see section 5-2)
- HS-2750 uses lithium battery. Recommended range of storage : Temperature : 25+/-5oC, under 60oC during transportation. Humidity : 25% ~ 85%, out of this range might affect the performance of the charger and battery.
- If storing your power chair for a prolonged period (3 months or more), full charge the batteries and store the batteries in a dry, well-ventilated environment. Batteries must be recharged every six months at least if storing for more than six months.
- The efficiency and lifetime of batteries will vary depends on the usage of the batteries. The improper charging way or insufficient equipment will minimize batteries' lifetime.
- Please do not charge non-stop over 15 hours.
- Batteries are subject to disposal and recycling regulations that vary by country and region. Always check and follow your applicable regulations before disposing of any battery.
- It's highly recommended to have your power chair inspected for battery every six month despite how often you use the power chair. Please contact your dealer.



- Do not sit or operate the power chair when charging.
- Store the lithium battery and charger in a dry, well-ventilated environment, away from any source of direct heat, humidity, oil, acid, alkaline, and ozone to prevent overheating, fire, malfunctioning or shortening of lifespan.
- Do not cover charger by any objects. Use the charger in a well-ventilated area. Do not smoke and keep away from open flames as explosive gases may be generated while charging the batteries.
- Please only use the original batteries and charger, well control the charging time to prevent damage to batteries and equipments. Do not use chargers from other brands or connect the charger with an extension chord.
- Do not disassemble charger, battery box and open sealed parts by yourself to prevent danger of electric shock and liquid leakage.
- Do not damage or disassemble battery box to avoid damaging on internal battery.
- Always avoid batteries short-circuit.
- In case of any malfunction, strange smell, heat, discoloration or deformation on lithium batteries, remove the battery before having dealer for repair.
- Rough handling operations, throwing, rolling, crushing, shaking, overly strong impact and extrusion to batteries should be avoided, to prevent battery casing broken or internal structure damage.
- Maintenance & repair must only be carried out by a competent engineer or authorized dealer. Please contact dealer if you need to replace internal battery.

### 5-2 CHARGING OPERATION

※ There are two charging ports, one is on battery box, and the other is on remote module.

#### Battery box charging port

1. Pull the security latch (under the seat) open (Fig. 16-1) to pull the battery box out (Fig. 16). To reinstall, level the battery box with the slide rails and pull the security latch open (Fig 16-1), then push the box inwards until a "click" sound is heard to lock it in place.

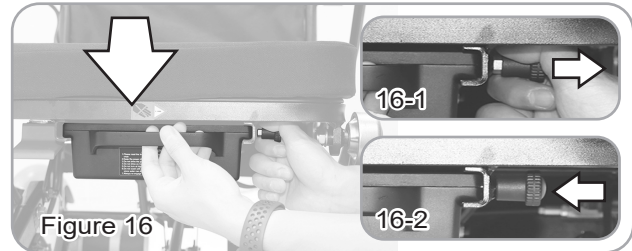

- **Watch out for pinching.**
- **The detachable battery box must be pushed in completely and made sure it can't be loosened to lock in place.**

2. Take the originally equipped charger (A) to connect the charger output cable (E) to the charging port (F) of the battery box. Connect the AC power cord (B) to a standard wall power outlet (C). Check if the LED (orange) light turns on (in charging).

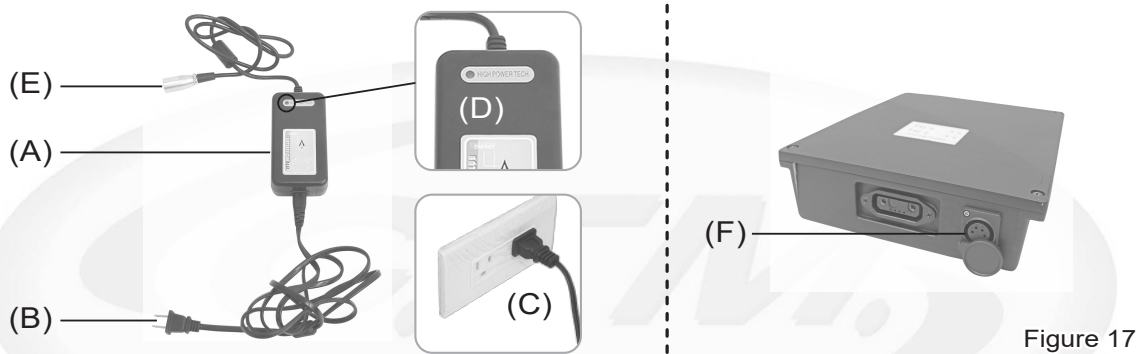

#### LED Light indicator (D)

The LED (red) light will turn on when power on. The LED (orange) light will turn on when the battery is in charging. When the battery is full charged, the LED light turns green.

#### Remote charging port

1. Plug the charger converter connector (I) into the joystick controller charging port (G).
2. Connect the other connector (J) into the charger output cable (E).
3. Connect the AC power cord (B) to a standard wall power outlet (C). Check if the LED (orange) light turns on (in charging).

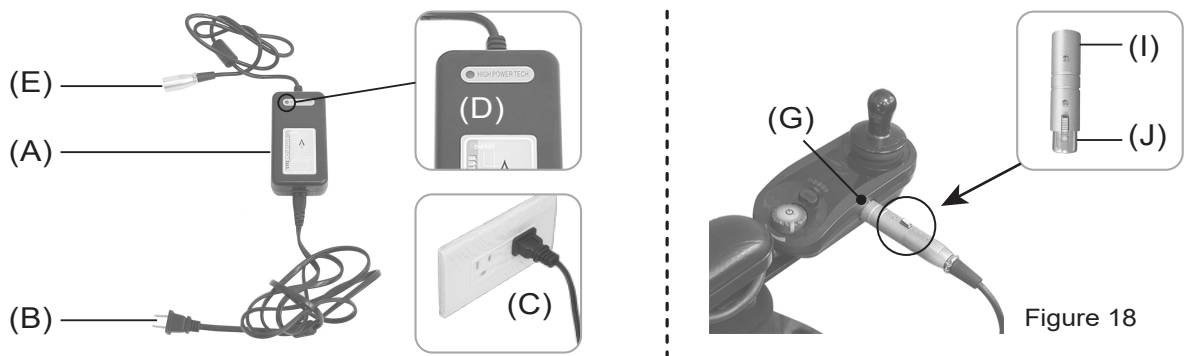





The time needed to a full charge will be around 7 hours. Disconnect the AC power cord (B) right after charging. The charger LED light indicator (D) should light up green when fully charged. If not, it is a sign of charger (A) or battery malfunction. Please contact your authorized dealer. Do not attempt to repair by yourself.

Please be aware that the travelling range of your power chair is impacted by how fast the batteries are discharged. This will depend on many circumstances, such as ambient temperature, condition of the surface of the road, tyre pressure, weight of the driver, driving environment (inclines etc.) and utilisation of your lighting system if fitted. We recommend that you test your local ride with a family member to ensure a safe journey.

### 5-3 BATTER GAUGE OPERATION

The battery gauge comprises five different LEDs (1 x red, 2 x orange, 2 x green), situated above the remote module's horn button.

※ The number of LEDs lit depends on the status of the battery, as shown below.

Battery Gauge	Status
	Fully charged. This level is set by the Battery Gauge Maximum parameter.
	Operate normally. Pay attention to the battery voltage.
	Operate normally. Pay attention to the battery voltage.
	Consider charging battery
	Battery needs charging. This level is set by the Battery Gauge Minimum parameter.

Please contact your authorized dealer for any malfunction.

## 6.TROUBLE SHOOTING

### 6-1 STATUS INDICATOR ERRORS



Figure 19  
The status indicator

If, when powered up, there is an error with the system, then the status indicator will flash red. The number of flashes will indicate the type of error. These are described in the table below.

Flash code	Error description
1	Remote / joystick error
2	Network or configuration error
3	Left motor error
4	Right motor error
5	Left park brake error
6	Right park brake error
7	Module error (other than Remote)

For more information about the error, and what to do about it, open the logs within one of the programming & diagnostic tools.

### 6-2 THE BATTERY GAUGE INDICATION

※ Always check number of flashes to prevent battery running down during driving.

#### High voltage warning



Figure 20

A high voltage warning is indicated by all LEDs on, and the green LEDs flashing. This occurs when the battery voltage level has risen above the high voltage warning set-point.

#### Low voltage warning



Figure 21

A low voltage warning is indicated with the left-most LED flashing. This occurs when the battery voltage level has decreased below its low voltage warning set-point. Charge the battery immediately.

**Cut-off voltage**



Figure 22

When the battery voltage decreases below the battery cut-off voltage:

- the first (red) LED will flash on the battery gauge
- the horn will sound once every 10 seconds
- Charge the battery immediately to avoid damaging the battery.

**OONAPU**



Figure 23

OONAPU ("Out Of Neutral At Power Up") is a safety feature that prevents accidental movement of the wheelchair, either when powering up, or when the wheelchair comes out of an inhibit state.

If the LiNX LE System is turned on (or comes out of an inhibit state) while the joystick is not in the centre position, an OONAPU warning is displayed. During an OONAPU warning, the battery gauge LEDs will flash continually to alert the user, and the chair will not drive. If the joystick is returned to the centre position within five seconds, the warning will clear and the wheelchair will drive normally.

However, if the joystick remains out of neutral for longer than five seconds, an OONAPU error will occur; the error is displayed by the Status indicator flashing red, and the chair will not drive. To clear the error, return the joystick to the neutral position and power the unit off and then on again.

**Drive inhibit indication**

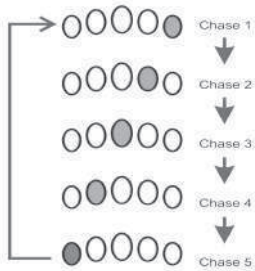

Figure 24

Drive inhibit mode is indicated by the battery gauge with a right-to-left chase sequence.

The chase sequence starts with the green LED on the right-hand side, and one-by-one, each LED will switch on and then off. When the sequence completes at the left-most red LED, it begins again at the right-hand side.

The chase sequence continues until the error condition has been cleared. (see section 6-1 for error indication)

**Battery charging**

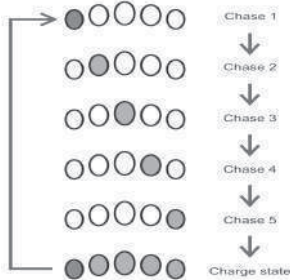

Figure 25

Plug the battery charger into the Remote's XLR socket.

The Battery Gauge will indicate the system is being charged by cycling between a left-to-right chase sequence, and then displaying the approximate battery charge state at the end of the chase sequence.

Driving is prevented (inhibited) while the system is being charged.

Please see actual charging status as per LED light indicator of charger. (see section 5-2)



## 7.MAINTENANCE AND CLEANING

### 7-1 REGULAR MAINTENANCE AND CLEANING

The power chair needs some basic attention to ensure it provides reliable service. We recommend that the user ensures that the power chair is checked regularly for maintenance requirements and receives a thorough, annual maintenance check up.

#### Annual Maintenance

We recommend that the chair has at least one full service per year from an authorized dealer. This will ensure that your power chair is functioning properly and also helps prevent future complications. This should include :

- Armrest/handle bar: Only use damp cloth with gentle detergent or 75% alcohol to wipe the surface. Do not use abrasive cleaners.
- Seat Upholste/ backrest: Use vacuum cleaner or damp cloth with gentle detergent to wipe the seat. Do not use abrasive cleaners as this will damage the seat. Do not sit until the seat dries out.
- Remote module/Metal parts: Only use damp cloth to wipe and use dry cloth to dry out immediately. Do not use abrasive cleaners as this will damage the parts. When power chair dries out, the shroud can be applied with a light of wax to keep its gloss.
- Joints of parts (like font wheel fork, axle): Apply a little grease when the part is making a grinding noise.

#### Regular Maintenance and Cleaning

- 01.Please turn off the power chair and make sure the lever is in Drive position before inspection or maintenance to avoid roll-away.
- 02.User should inspect the power chair more often especially when the power chair has possibly been riding on the bad road condition such as, grass, sand, bumps, and potholes.
- 03.Clean the dusts by old toothbrush before applying grease.
- 04.Avoid knocking or bumping the controller, especially the joystick.
- 05.Avoid prolonged exposure of your power chair to extreme conditions, such as heat, cold, or moisture.
- 06.Keep the controller clean.
- 07.Check that all controller connectors are tight and secured properly.
- 08.Never hose off your power chair or place it in direct contact with water.
- 09.Keep the upholstery and frame clean by wiping with a soft cloth, particularly after driving through wet, sandy or muddy conditions. Do not use harsh abrasive materials when cleaning. Do not apply liquid cleaners or solvents directly to the control box, battery charger or any electrical connections.
- 10.Keep wheels free from lint, hair, sand and carpet fibres.
- 11.Lightly oil axle pin, wheel axles and bearings once every three months, if necessary.
- 12.Inspect the tires. Tread depth should not be allowed to drop below 1mm.
- 13.Use only recommended batteries and have batteries changed by Qualified Dealer if you have doubts about your ability to lift the components.
- 14.Charge batteries regularly. Make sure the charger lead plugs are engaged properly in the sockets. Do not disconnect by pulling the cord.
- 15.With the controller turned off, check the joystick. Make sure it is not bent or damaged and that it returns to the center when you release it. Check the rubber boot around the base of the joystick for damage. Visually inspect the boot. Do not handle or try to repair it. See your authorized dealer for any questions.
- 16.Visually inspect the controller harnesses. Make sure that they are not frayed, cut or have any wires exposed. See your authorized dealer if there is a problem with any of these harnesses.
- 17.Make sure all components of the control system are securely fastened to your power chair and don't over-lock any connector screws to prevent them from loosening.

## 7.MAINTENANCE AND CLEANING

### 7-2 INSPECTION CHECKS

Please always check your power chair before you start your every journey. if you find the sign of power chair malfunction, please contact your authorized dealer.

Check point	Inspection	What to do if the inspection is failed
Remote module	Check if the LED light indicator lights up after powering on.	Contact your dealer
	Check if there is any error indication on status indicator or battery gauge.	Please refer to section 6-1 / 6-2.
	Check if the battery gauge is displayed and whether it is at low power.	※ Contact your dealer if battery gauge is not working. ※ Recharge the battery immediately if low. (Please refer to section 5-3.)
	Check for correct function of buttons and joystick.	Contact your dealer.
	Check for the horn button to sound the horn.	
Motor	Check for correct function, no noisy sound, malfunction or overheat.	Contact your dealer.
Brake	Release the joystick to test if brake works.	Contact your dealer. ®
N-D lever	Check for correct function.	Contact your dealer.
Mechanical Structure	Check if folding/unfolding function is acting smoothly without noise.	Contact your dealer.
	Check if there is any deformation or loose on joint of frame, handrail bracket and footrest.	
	Check if there is any loosen part.	Please tighten the screws.
Battery Box	Check if the battery gauge lights up after connecting with the charger.	Check for the connection and make sure it is connected firmly.
	The charger LED light indicator does not light up green when fully charged.	
Wheels / Tires	Check if tire tread depth is less than 1mm.	Contact your dealer.
	Check if the tire has cracks or deformation. No foreign objects in tires.	
	Check the tire pressure.	
	Check that wheels rotate without wobbling.	
Battery Charger	Check if the charger is functioning correctly and the batteries are charged.	Contact your dealer.

## 8.ACCESSORIES

### 8-1 Optional Accessories

Please contact your distributor if you need the accessories below.

High Capacity 30.15Ah Batteries



Increases power chair endurance.

Seatbelt



Increases stability during ride.

----

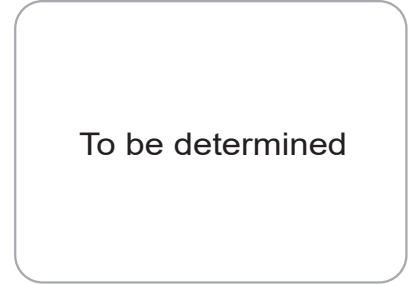

To be determined



## 9.SPECIFICATION

Overall Length	1055 mm / 42"
Overall Width	635 mm / 25"
Overall Height	1030 mm / 40.6"
Front Wheels	200 mm / 7.8"
Rear Wheels	320 mm / 12.6"
Weight W/ Batteries	29.5 kg / 65 lbs
Max. Speed	8 kmph / 5 mph
Weight Capacity	150 kg / 330 lbs
Ground Clearance	85 mm / 3.3"
Grade Climbable	6 degree
Curb Climbable	30 mm / 1.2"
Turning Radius	950 mm / 37.4"
Brake	Electro-Mechanical
Seat Type	Padded Breathable Nylon Back Rest
Seat Width	460 mm / 18"
Drive Train	2 Motor, Rear-Wheel Drive
Motor Size	24V / 250W / 3250 r.p.m.
Battery Size	(1) 25.9V / 11.6Ah
Weight of Battery	2.45 kg / 5.4 lbs
Travel Range	14 km / 8.7 Miles
Battery Charger	2A Off Board

\*Subject to change without notice. ( Rev. 0, 2023/05/05 )