

# FOCUS *CR* & *CRe*

---

HAND TILT ADJUSTMENT GUIDE



## Objective - Single Cable Tilt (Locked)

Fig. 1

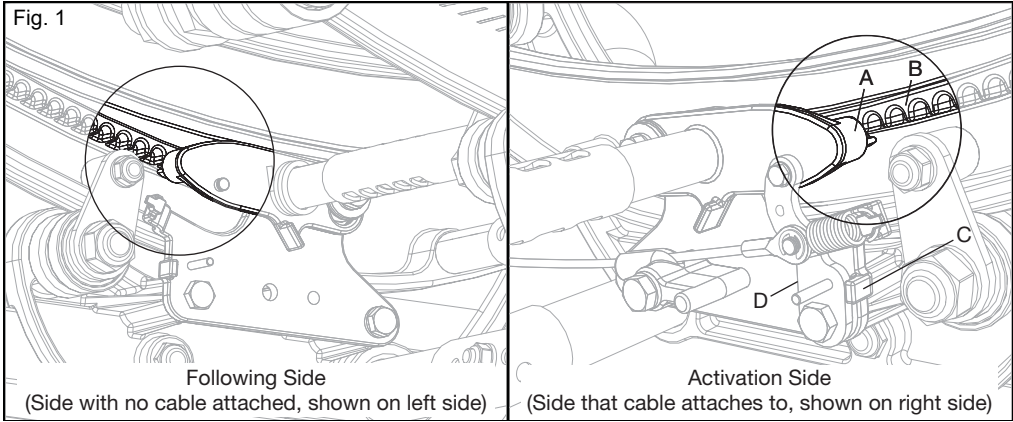

Lower linkage (D) is locked and rests against the tilt stop (C). Linkage cannot move. Cog (A) is engaged in the rotary frame teeth (B). Tilt system is locked.

## Objective - Single Cable Tilt (Unlocked)

Fig. 2

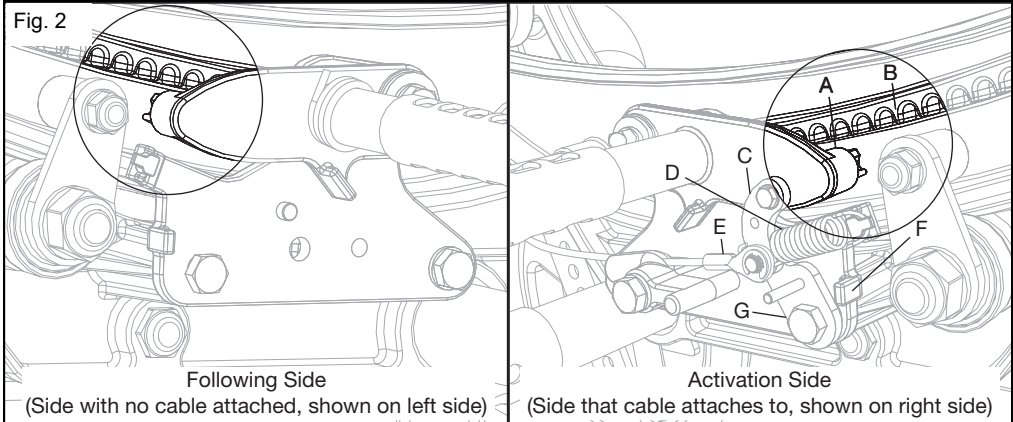

When trigger is pulled, the cable (E) pulls the pivot point and spring (D) is overcome allowing linkage (C and G) to pull the cog (A) down and disengage from the rotary frame teeth (B). Note the lower linkage (G) is pulled away from the tilt stop (F). Tilt system is unlocked. Cog has clearance from teeth.

## Objective - Dual Cable Tilt (Locked)

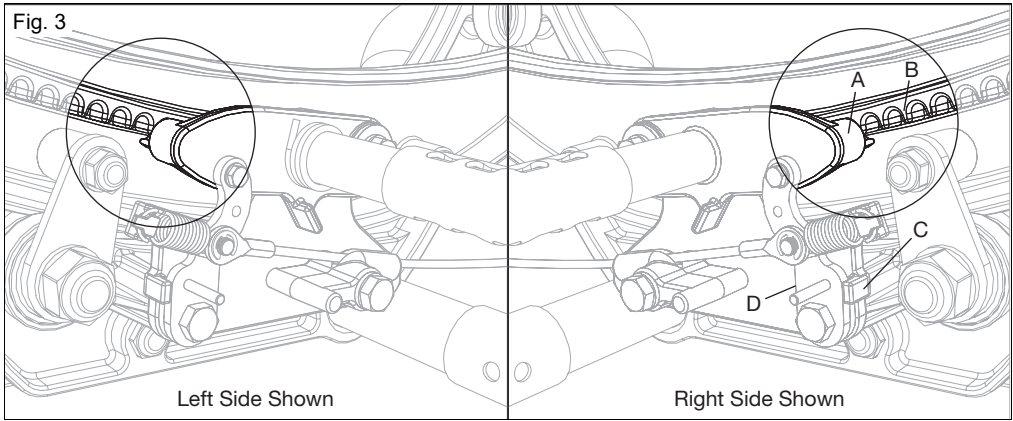

Lower linkage (D) is locked and rests against the tilt stop (C). Linkage cannot move. Cog (A) is engaged in the rotary frame teeth (B). Note that both sides of tilt mechanism mirror each other. Tilt system is locked.

## Objective - Dual Cable Tilt (Unlocked)

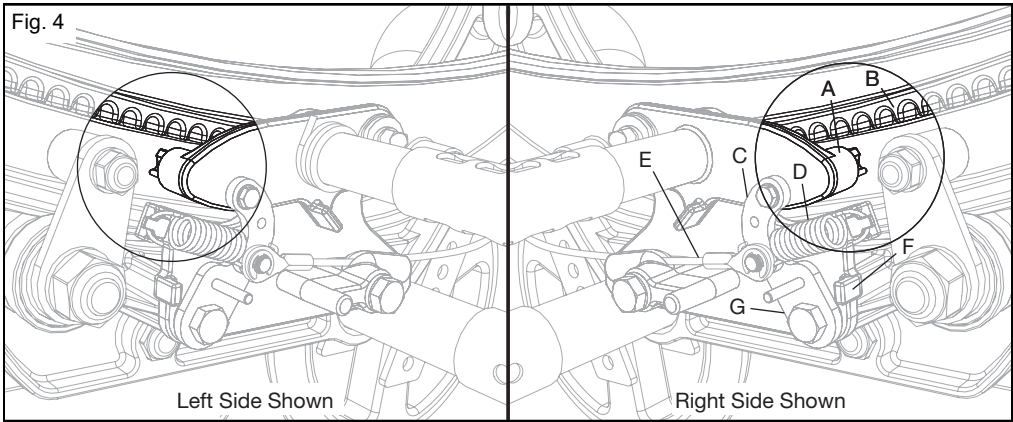

When trigger is pulled, the cable (E) pulls the pivot point and spring (D) is overcome allowing linkage (C and G) to pull the cog (A) down and disengage from the rotary frame teeth (B). Note the lower linkage (G) is pulled away from the tilt stop (F). Tilt system is unlocked. Cog has clearance from teeth.

# Symptoms

## 1. Clicking Noise

A clicking noise is heard during the action of tilting the chair. This is caused by the cog hitting the rotary frame teeth as the chair tilts. Clicking is caused by the cable being too loose or the trigger(s) not being engaged fully. This may occur on one or both sides.

Fig. 5

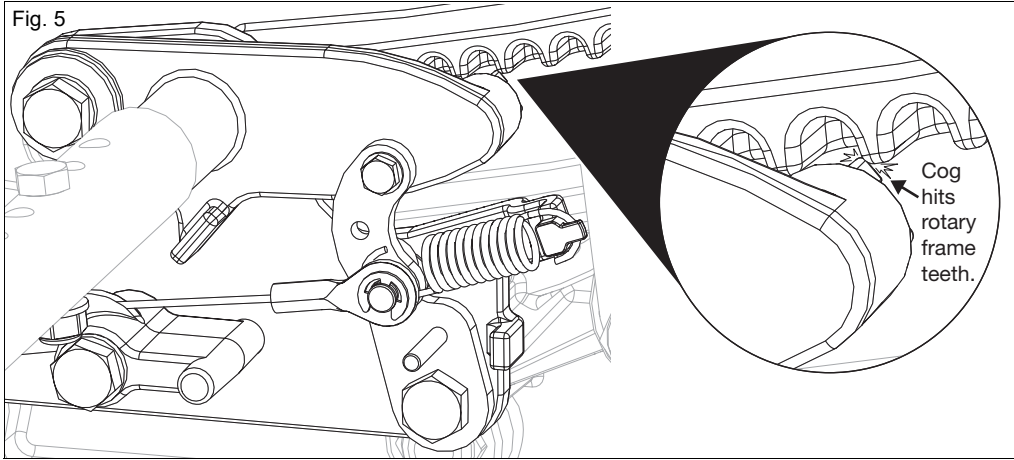

## 2. Tilt Not Locking / Difficulty Unlocking Tilt Mechanism

Chair may seem difficult to start and end the tilting process. It may take some wiggling to lock/unlock the tilt mechanism. This is caused by:

1. Improper bolt tightening (See Potential Solution - Section C for correcting)
2. Improper cable routing (See Fig. 6 for image of issue. See Potential Solution - Section A for correcting)
3. Cable being too tight or too slack (See Fig. 7 for image of issue. See Potential Solution - Section B for correcting)
4. Improper drive insert issues (See Potential Solution - Section E for correcting)
5. COG adjustment needed (See Fig. 8 for image of issue. See Potential Solution - Section F for correcting)

Fig. 6

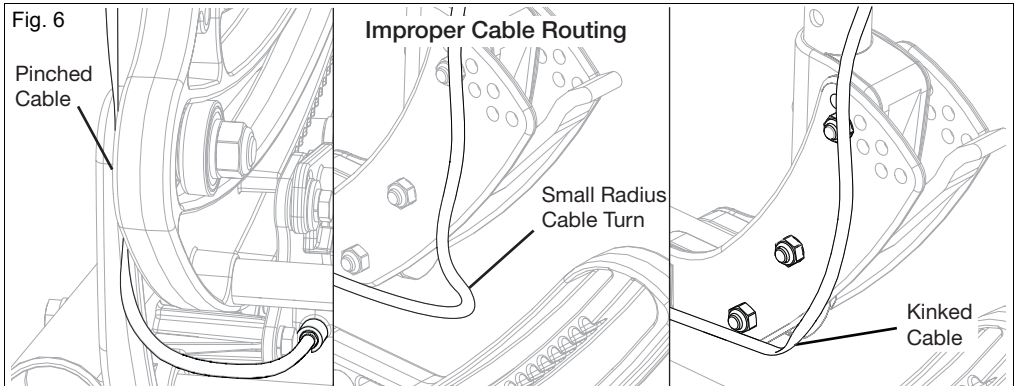

There are different points on the chair where the tilt cable may become pinched, kinked or have too tight of turns (small radius cable turn) which causes friction.

# Symptoms

Fig. 7

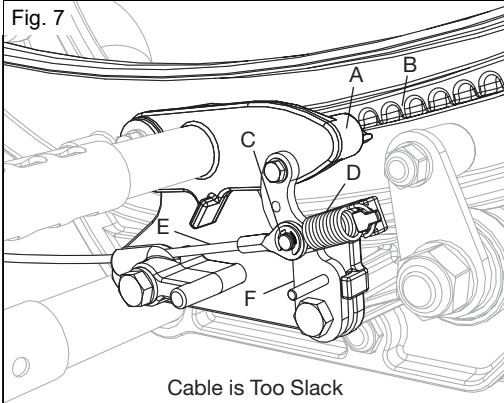

Cable is Too Slack

When cable adjuster is too short, cable (E) is too long, the tilt mechanism is not fully actuated at the pivot point (C). The spring (D) is not overcome and the linkage (F) does not pull the cog (A) down and out of the rotary frame teeth (B).

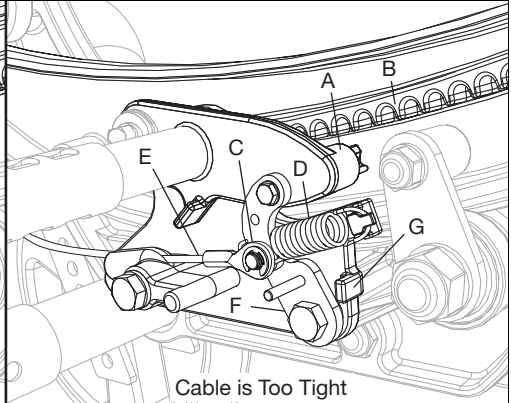

Cable is Too Tight

When cable adjuster is too long, cable (E) is too tight, the tilt mechanism does not fully lock and the linkage (F) does not rest against the tilt stop (G). This prevents the cog (A) from fully engaging into the rotary frame teeth (B).

Fig. 8

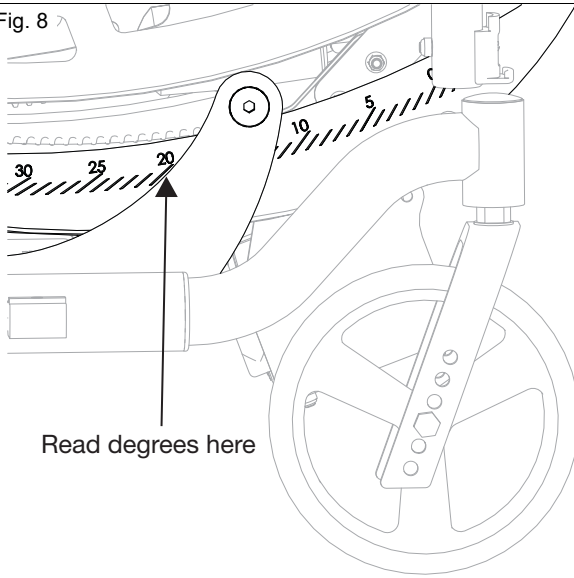

Read degrees here

## Test for Proper COG Settings

Improper COG settings will result in a reading that falls outside the acceptable range and will cause difficulty in initiating tilt. Lock wheel locks (if equipped). Place occupant in chair with all equipment that attaches to upper frame, such as foot boxes, backpacks, etc. Squeeze triggers or depress foot pedal and allow rotary frame to find its resting place. The tilt angle degree reading should be between 17° and 23°.

# Symptoms

---

## 3. Tilt Mechanism Won't Lock / Locks Intermittently

The tilt mechanism may not lock or occasionally catches and locks. This could be caused by improper cable routing (See Fig. 6 for image of issue. See Potential Solution - Section A for correcting), cable being too tight or too slack (See Fig. 7 for image of issue. See Potential Solution - Section B for correcting) or improper bolt tightening (See Potential Solution - Section C for correcting).

## 4. One Side of Tilt Mechanism Sticks

One side of the tilt mechanism may not lock / unlock or operate as smoothly as the opposite side. This is caused by improper cable routing (See Fig. 6 for image of issue. See Potential Solution - Section A for correcting), cable being too tight or too slack (See Fig. 7 for image of issue. See Potential Solution - Section B for correcting) , improper bolt tightening (See Potential Solution - Section C for correcting) or improper drive insert placement (See Potential Solution - Section E for correcting).

## 5. Difficulty Squeezing Tilt Lever

The tilt lever, or levers, are difficult to squeeze to start the tilt process. This could be caused by improper cable routing (See Fig. 6 for image of issue. See Potential Solution - Section A for correcting), COG adjustment being needed (See Fig. 8 for image of issue. See Potential Solution - Section F for correcting) or improper bolt tightening (See Potential Solution - Section C for correcting).

# Potential Solutions

## A. Improper Cable Routing Solution

Correct any pinch points, tight turns (small radius cable turn) or kinks. Proper cable routing will help prevent cable issues. Before correcting any cable issues, always check the condition of the cable and replace if damaged.

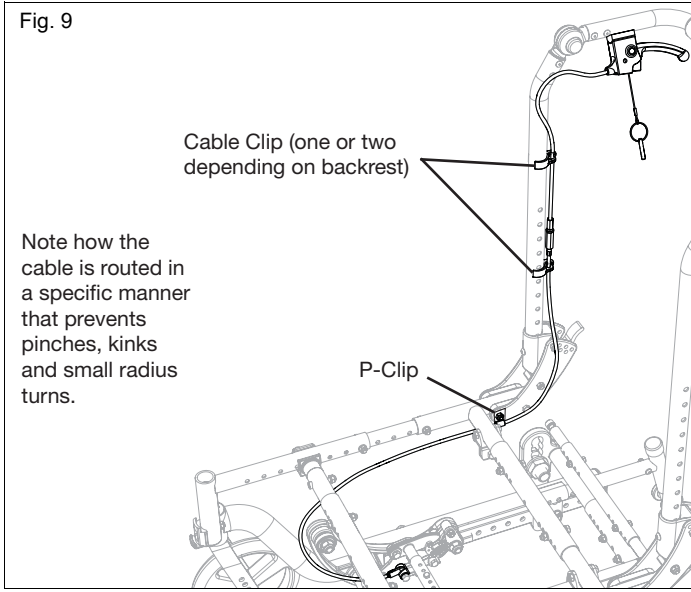

**NOTE:** Cable must loop around front of the rocker and not be large enough to catch on the transit bracket. See Fig. 10.

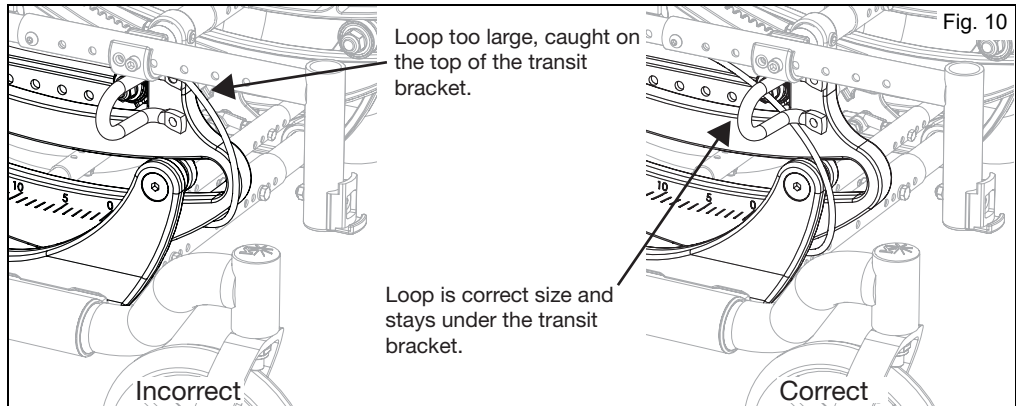

# Potential Solutions

## B. Cable Adjustment Solution (Cable has too much slack or is too tight)

Loosen the jam nut (A). Hold the top portion of cable adjustment hardware and turn the adjuster (B) clockwise to remove slack and counterclockwise to increase slack. The trigger should move no more than 1/8" before pulling the cable (F) and linkage (C and H). The lower linkage (H) should also rest against the tilt stop (I) with the cog (D) engaged in the rotary frame teeth (E). Test the levers after each adjustment to ensure levers engage properly and tilt mechanism releases and locks. Tighten jam nut.

Fig. 11

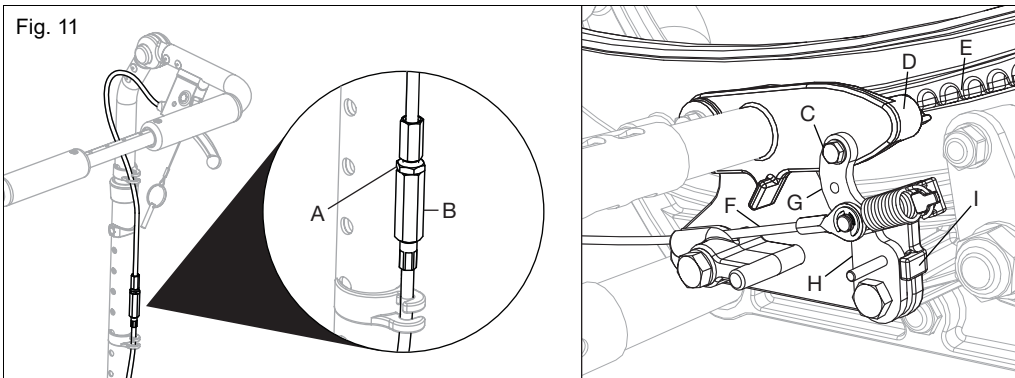

**NOTE:** If cable adjustment solution does not resolve issue - Sometimes a damaged or binding cable jacket will show symptoms similar to cable routing or cable adjustment issues. Check the cable for hidden or undiscovered damage, remove the screw (A), nut (B) or E-Clip (C) (depending on your revision of tilt mechanism) and release the cable eyelet (A) from the tilt mechanism. The tilt trigger should be able to be moved freely without any resistance. If there is resistance, the jacket is kinked and/or is binding. Replace cable if you are unable to correct through proper cable routing and inspection.

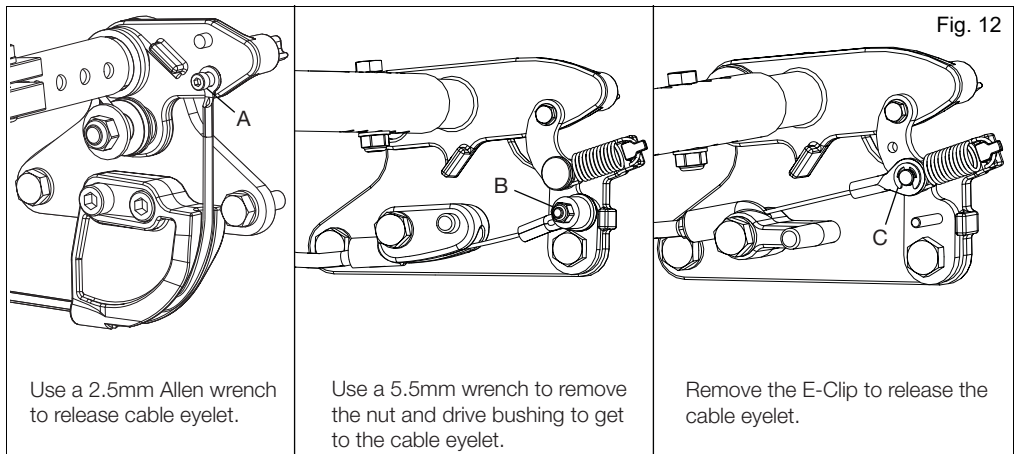
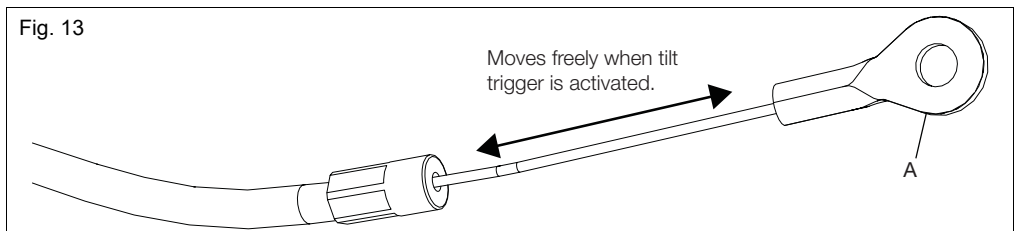

Fig. 12

Fig. 13





# Potential Solutions

## C. Incorrect Bolt Tightening Solution

Bolts A, B, C and D should be tightened snug. Bolt E should be fully tightened. Inspect the following - cable guide under bolt C for cracks and crush points, nylon washers under bolt D ensuring washer is intact and linkage system is free moving. Release linkage spring and confirm. If it is stiff at the bottom linkage, replace brass bushing under bolt B. Also check bolts B, D, and E on opposite side if the chair uses a single cable tilt. Check all of the bolts on the opposite side if the chair uses a dual cable tilt.

Fig. 14

### Incorrect Bolt Tightening Issue

#### Bolt D

If bolt is overtightened it will not allow the cog lever to move properly.

#### Cog Lever

#### Bolt A

If bolt is overtightened, the linkage movement is affected.

#### Bolt E

#### Bolt C

If bolt is overtightened, the cable guide can become crushed or cracked which can affect the pull and release of the cable.

#### Bolt B

If bolt is overtightened, the brass bushing underneath becomes crushed and linkage movement is affected.

## D. Cable Alignment to Tilt Mechanism Solution (Related to cable routing)

Ensure cable is attached and routed correctly on the tilt mechanism. Reference the revision type on your chair in Fig. 15.

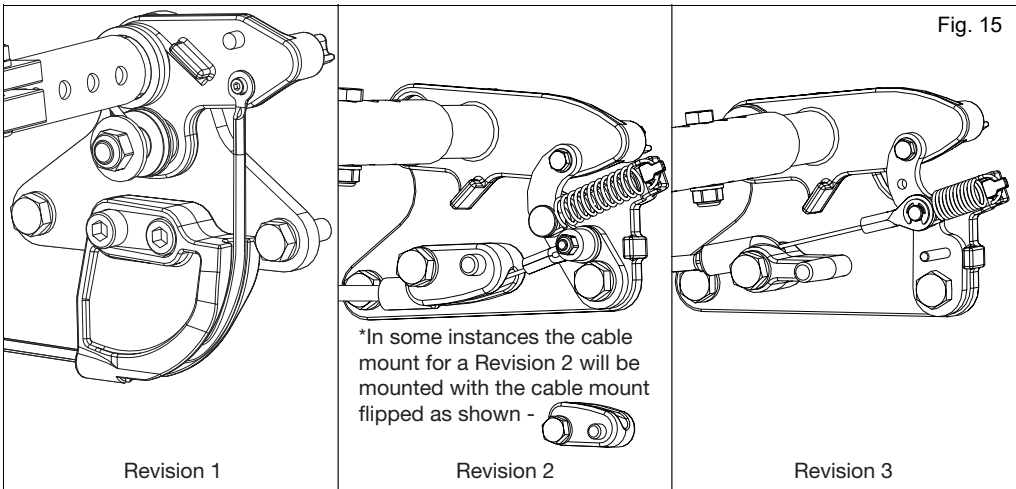

# Potential Solutions

## E. Improper Drive Insert Issue Solution

Ensure the long end of drive insert on the **top** of the strut tube is facing the front of the chair. The long end of the drive insert on the **bottom** of strut tube should be facing the rear of the chair (opposite of the top drive insert). See Fig. 16.

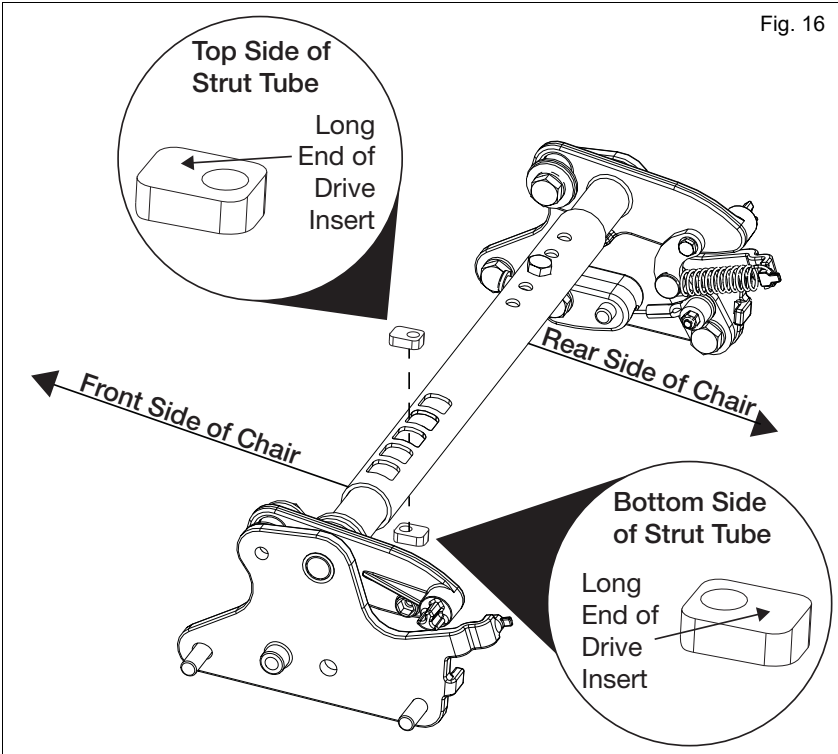

# Potential Solutions

## F. COG Adjustment Solution

If the test in the Improper COG Settings section showed that adjustments are needed, follow the diagram, table and instructions below to correct.

- Remove the seat frame position locking screws (Fig. 17:B) using a 5mm Allen wrench.
- If resting angle is larger than 23°, pull seat frame toward the front of the chair until approximate 20° resting angle is achieved. If frame rests at an angle smaller than 17°, push seat frame toward the rear until approximate 20° is achieved.
- Different occupants will respond differently, but a good starting point is to move the seat frame ½" for every 5° that the angle is off from 20°.
- Once optimum position is achieved, reinstall and tighten positioning screws in holes closest to optimum position. Screws may be placed in front or rear hole of seat frame saddle (Fig. 17:A).

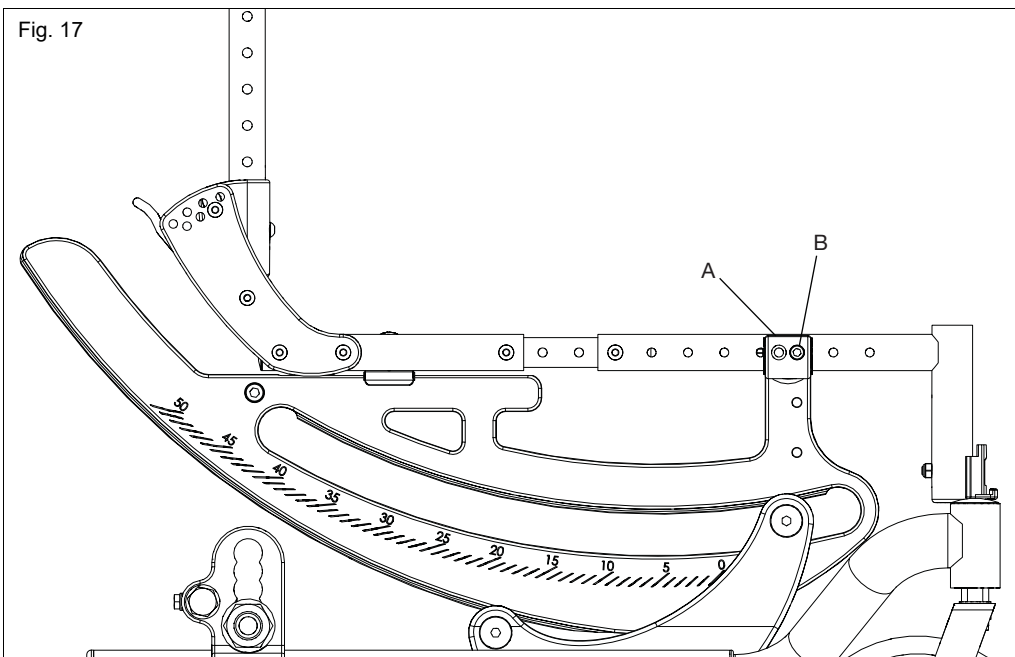

System Resting Position	Adjustment Required
System Rests Between 50 and 45	3 Holes Forward
System Rests Between 44 and 35	2 Holes Forward
System Rests Between 34 and 25	1 Hole Forward
System Rests Between 24 and 16	Acceptable
System Rests Between 15 and 7	1 Hole Rearward
System Rests Between 6 and -2	2 Holes Rearward
System Rests Between -3 and -5	3 Holes Rearward

\*System Includes Seating and End User

## Additional Help

For part information and ordering visit [www.kimobility.com](http://www.kimobility.com) or call 715-254-0991.

Always have the user read the entire owner's manual. BEFORE riding, the user should be trained in the safe use of this chair by an Assistive Technology Practitioner (ATP) or clinical professional.

If you have any questions or concerns about any aspect of this wheelchair, please do not hesitate to contact us

